

SUGINO

selffeeder™

SERVO series

Selffeeder Varimec
 Selffeeder Mechatric
 CNC Turret Head

Mechanical feed and electronic control drilling unit

selffeeder™

SERVO
 series



 **SUGINO MACHINE LIMITED**

<http://www.sugino.com>

1-9-13, Nihonbashi-Honcho, Chuo-ku, Tokyo, 103-0023 JAPAN
 ☎+81-3-5201-5974 FAX +81-3-5201-5978
 e-mail: export@sugino.com

Overseas Office

U.S.A.	Sugino Corp.	☎+1-630-250-8585 e-mail: mach@suginocorp.com	FAX +1-630-250-8665
Mexico	Sugino Machine Mexico, S.A. DE C.V.	☎+52-81-1100-0108 e-mail: ventas@sugino.com.mx	FAX +52-81-1100-0318
China	Sugino Shanghai Co., Ltd. Shanghai office	☎+86-21-5385-5031 e-mail: sh@sugino.cn	FAX +86-21-5385-5032
	Guangzhou office	☎+86-20-8363-4719	FAX +86-20-8363-4992
Thailand	Sugino Machine (Thailand) Ltd.	☎+66-3572-9351 e-mail: contact@sugino.th.com	FAX +66-3572-9355
Singapore	Sugino Machine Singapore Pte. Ltd.	☎+65-6458-9544 e-mail: sales@sugino-singapore.com.sg	FAX +65-6456-7789
Czech	Praha, Branch Office	☎+420-257-950-228 e-mail: info@sugino.cz	FAX +420-257-950-044

Highly rigid and long stroke (up to 300mm) drill unit with compact size. Variety of models available for wide ranges of machining requirements.

selfeeder servo series is a high-precision CNC controlled drilling unit capable to drill newly developed material and exotic material.

High quality servo motor for feed and precise ball screw designed eliminate the feed rate fluctuation of feed speed by drilling force; less burr generation for through hole drilling and longer tool life.

High precision, high efficiency, less space and cost reduction that are critical for the machining operation can be gained with this selfeeder servo series.



**Features of
Selfeeder
Servo series**

High quality drilling

The fluctuation of the feed speed is eliminated by the precise angular bearing supporting spindle and the high quality ball screw. As the result the generation of burr is reduced and the tool life is longer.



High-rigidity, high-precision structure

A newly developed structure holds the spindle ball screw and linear guide making the drill unit body rigid and strong enough to step spot face and burnish drilling. (JP PAT.)

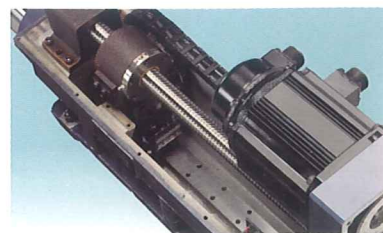

Selfeeder **Varimec**

A new generation model of Selfeeder Mechatric that has high rigidity to make a high performance with compact body.

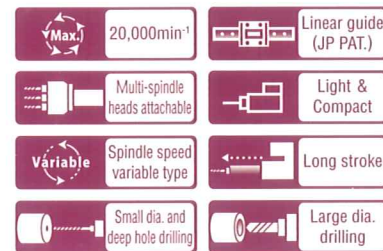

Aluminium φ8.5	Steel φ6.5	SSV2	4p
Aluminium φ12	Steel φ8	SSV3	6p
Aluminium φ16	Steel φ13	SSV4	8p
Aluminium φ25	Steel φ18	SSV5	10p

Selfeeder **Mechatric**

Multi functional basic unit featured with higher torque for large hole drilling and coolant center through etc.

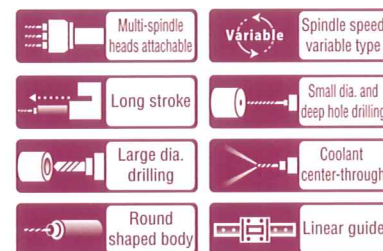

Aluminium φ16	Steel φ11	SSM4	12p
Aluminium φ24	Steel φ19	SSM5	14p
Aluminium φ14	Steel φ10	MS3P	16p
Aluminium φ40	Steel φ28	MS7	17p

CNC Turret Head

High-efficient model for intensive production to be capable for 4 different operations with single unit that is flexible for installation for new line as well as existing line as it is unit type.

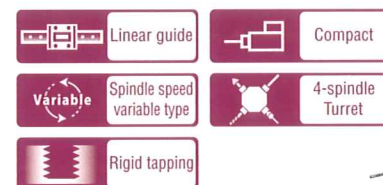

Aluminium φ12	Steel φ8	4TH3S	18p
Aluminium φ20	Steel φ13	4TH5	20p
Aluminium M16	Steel M12			

Data input system / other attachments 22-23p

Programming console, Touch panel, Computer monitoring software, Process patterns Varimotor, Standrill NC

High-efficient deep hole drilling

Coolant center through type (Max. 6.8MPa) is available for Mechatric series for efficient deep hole drilling by oil hole drill tool.

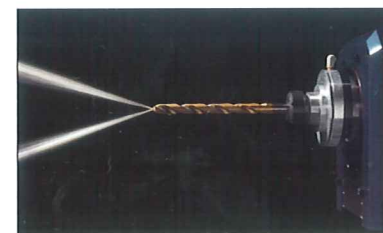

High-flexibility

Spindle rotation speed is variable by attached inverter. Optimize speeds to adapt to different cutting requirements.

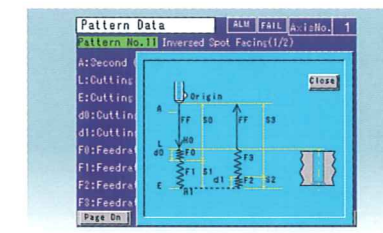

Easy operation

5.7inch touch panel type color display (liquid crystal) makes it easy to make a CNC program and operate even for a beginner operator. Four different languages are available for the oversea usage.



Max. Drilling size (mm)

Aluminium
φ8.5

Steel
φ6.5

Selfeeder Varimec

SSV2

- Max. 20,000min⁻¹
- Linear guide (JP PAT.)
- Light & Compact
- Variable Spindle speed variable type



The smallest model of Varimec utilizes a high-performance motor (high-speed and high-power) into a small, compact sized body.

It provides high performance for production of small parts and small-diameter drilling.

Specification Chart

Model	Specs.		Chuck type (Collet chuck)	Chucking capacity mm	Max. Drilling size			Stroke mm	Spindle motor kW	Feed motor kW	Thrust N	Rapid approach speed mm/sec	Cutting speed mm/sec	Weight kg
	Spindle speed (no load) 50Hz 60Hz min ⁻¹				AL* (ADC)	FC* (FC200)	ST* (S45C)							
SSV2-7200	2,000~20,000		ER11MS	0.5~7.0	5	4	3.5	Max. 80	0.9 15,000min ⁻¹ /hr. DC brushless motor	0.4 AC servo motor	1,200	Max. 200	Max. 16.7	15
SSV2-1039	390~3,900		ER16	0.5~10.0	8.5	7.5	6.5							

- Notes1. To select your model, refer to the workpiece configurations, material, cutting properties, diameter of the hole, and rotation speed.(cutting speed)
 2. The drilling capacity shown above is for a depth equivalent to the drill diameter times two.
 3. The power voltage of the main spindle inverter is a 3-phase 200V AC±10%, 50/60Hz. (Feeding axis controller is single-phase.)
 4. In the case of a servo motor with a holding brake (optional), add "B" to the end of the model number.
 5. AL...Aluminium, FC...Cast Iron, ST...Steel

Dimensions (mm)

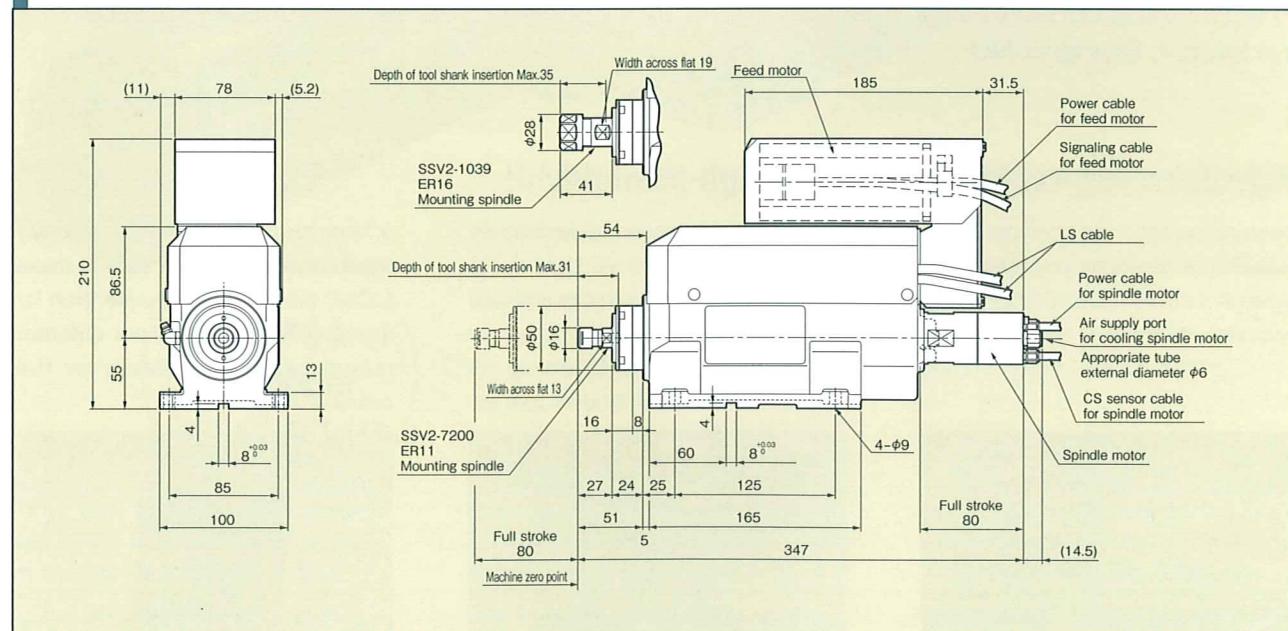

Note: Air must be supplied to cool the spindle motor as to protect the spindle bearings. Be sure to supply clean dry air.

Adjustable spindle nose (option)

Please specify the adjustable spindle nose when ordering your servo drill.

Sugino supplies adjustable spindle noses other than those shown below, upon request.

Applicable selfeeder	Fig. No.	Spindle nose model No.
SSV2-7200	1	KH-12E
SSV2-1039	2	KH-14E

Dimensions(mm)

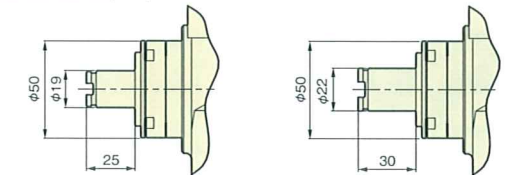

Fig. 1 KH-12E

Fig. 2 KH-14E

- Notes1. Spindle noses KH-E model are applicable to the quick change stub holder of KH-A or KH-E model of NT Tool Co.,Ltd.
 2. Quick change stub holder can not use in over 15,000min⁻¹ spindle speed operation.

Electric system diagram

All the electric parts supplied as standard are indicated in [] box.
 The purchaser is responsible for and needs to have the other cables and equipment.

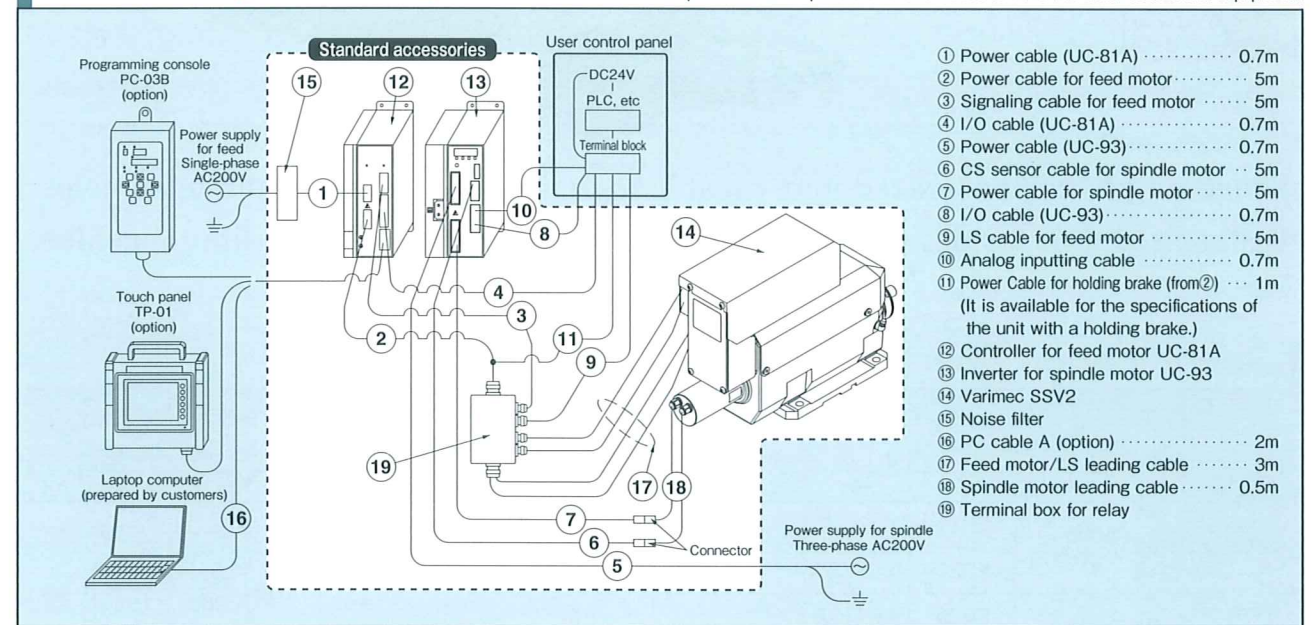

- ① Power cable (UC-81A) 0.7m
- ② Power cable for feed motor 5m
- ③ Signaling cable for feed motor 5m
- ④ I/O cable (UC-81A) 0.7m
- ⑤ Power cable (UC-93) 0.7m
- ⑥ CS sensor cable for spindle motor 5m
- ⑦ Power cable for spindle motor 5m
- ⑧ I/O cable (UC-93) 0.7m
- ⑨ LS cable for feed motor 5m
- ⑩ Analog inputting cable 0.7m
- ⑪ Power Cable for holding brake (from②) 1m
(It is available for the specifications of the unit with a holding brake.)
- ⑫ Controller for feed motor UC-81A
- ⑬ Inverter for spindle motor UC-93
- ⑭ Varimec SSV2
- ⑮ Noise filter
- ⑯ PC cable A (option) 2m
- ⑰ Feed motor/LS leading cable 3m
- ⑱ Spindle motor leading cable 0.5m
- ⑲ Terminal box for relay

- Notes1. The feed controller and the spindle inverter are standard accessories.
 2. The programming console and touch panel is optionally available. The attached cable is 3m long.
 3. Programming from a computer is possible using a ⑯ PC cable A. In such case, a dedicated computer monitoring software is required.
 Working environment: OS Windows 95/98/XP (The mode setting is necessary), Communication interface RS232C-port.

Controller for feed motor UC-81A

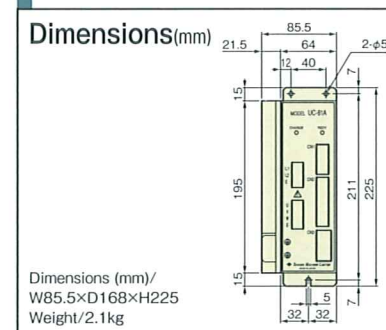

Inverter for spindle motor UC-93

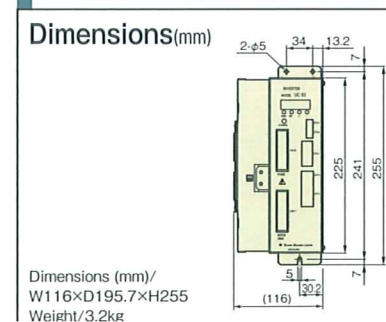

Specification of signal

I/O	Signal	Contents
Analog Output	ORD	Command for spindle speed
	COM	Ground of command for spindle speed
	IN0	Emergency stop
	IN1	Manual coolant ON/OFF
	IN2	Power "ON"
	IN3	Machine zero return
	IN4	Single step
	IN5	Spindle alarm
	IN6	JOG+
	IN7	JOG-
	IN8	Forward side OT
	IN9	Backward side OT (Combine with origin LS)
Input	NC	No contact terminal
	IN10	Alarm clear
	IN11	EXT/MANUAL
	IN12	Manual spindle ON/OFF
	IN13	Program 1
	IN14	Program 2
	IN15	Program 4
	IN16	Program 8
	IN17	Program 10
	IN18	Program 20
	IN19	Program 40
	IN20	Program 80

I/O	Signal	Contents
Output	OUT0	RDY
	OUT1	Cycle run
	OUT2	Program end
	OUT3	Origin
	OUT4	Spindle ON
	OUT5	Ready for single step
	OUT6	Coolant ON
	OUT7	Forward sideON
OUT8	Alarm	

- ※1 Voltage: DC24V, Electric current: 10mA
 ※2 Voltage: DC24V, Electric current: 90mA

Max. Drilling size (mm)

Aluminium
φ12

Steel
φ8

Selfeeder Varimec

SSV3

- Max. 10,000min⁻¹
- Linear guide (JP PAT.)
- Multi-spindle heads attachable
- Light & Compact
- Variable Spindle speed variable type
- Long stroke
- Small dia. and deep hole drilling



Short length, compact sized unit capable to drill small diameter and deep holes. Well suited unit for designing/producing low cost and flexible drilling machine.

Specification Chart

Specs.	Spindle speed (no load)		Chuck type (Collet chuck)	Chucking capacity	Max. Drilling size			Stroke	Spindle motor	Feed motor	Thrust	Rapid approach speed	Cutting speed	Weight
	50Hz	60Hz			AL* (ADC)	FC* (FC200)	ST* (S45C)							
Model	min ⁻¹		—	mm	mm	mm	mm	kW	kW	N	mm/sec	mm/sec	kg	
SSV3-7100	1,000~10,000		ER11	0.5~7.0	6.5	5	4	Max. 200	0.4 DC brushless motor	0.4 AC servo motor	1,660	Max. 200	Max. 16.7	43
			ER20	0.5~13.0										
SSV3-1626	265~2,650		ER20	0.5~13.0	12	9	8							
			ER25	0.5~16.0										

- Notes 1. To select your model, refer to the workpiece configurations, material, cutting properties, diameter of the hole, and rotation speed.(cutting speed)
 2. The drilling capacity shown above is for a depth equivalent to the drill diameter times two.
 3. The power voltage of the main spindle inverter is a 3-phase 200V AC±10%, 50/60Hz. (Feeding axis controller is single-phase.)
 4. In the case of a servo motor with a holding brake (optional), add "B" to the end of the model number.
 5. AL*...Aluminium, FC*...Cast Iron, ST*...Steel

Dimensions (mm)

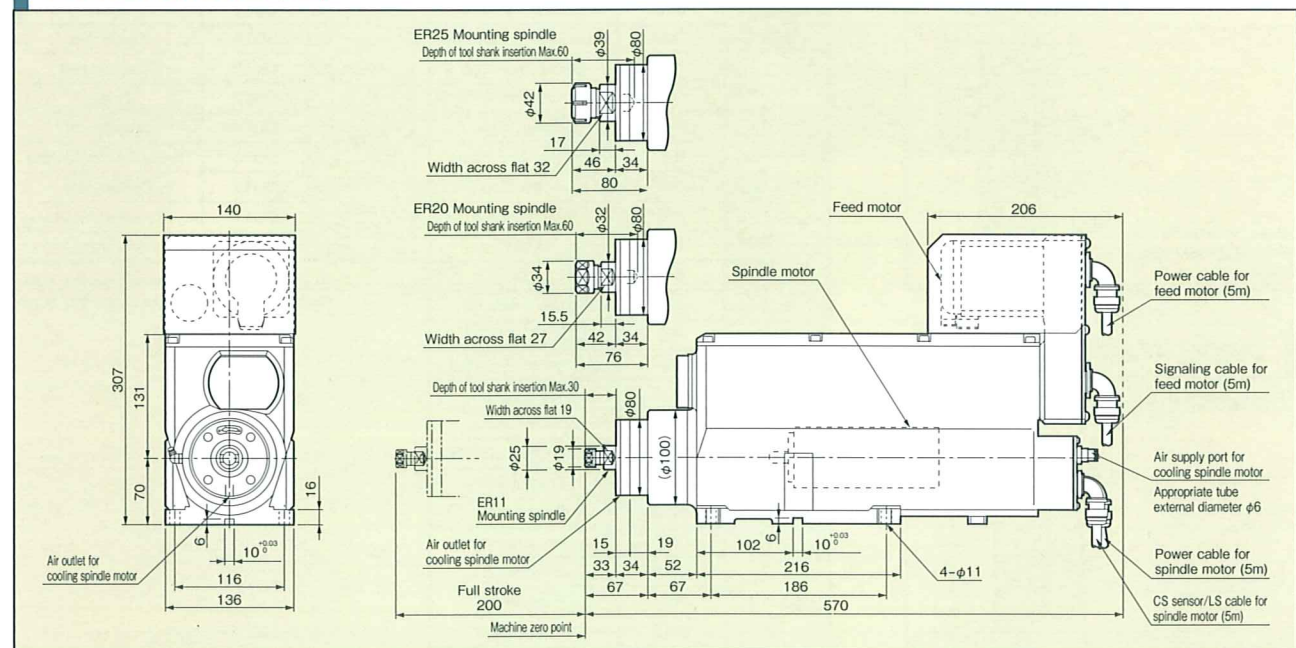

Note: Air must be supplied to cool the spindle motor as to protect the spindle bearings. Be sure to supply clean dry air.

Adjustable spindle nose (option)

Please specify the adjustable spindle nose when ordering your servo drill. Sugino supplies adjustable spindle noses other than those shown below, upon request.

Applicable selfeeder	Fig. No.	Spindle nose model No.
SSV3-7100	1	KH-14AR
SSV3-1626	2	KH-25A

Dimensions(mm)

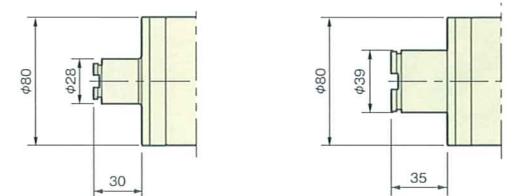

Fig. 1 KH-14AR

Fig. 2 KH-25A

Notes: Spindle noses KH-A model is applicable to the quick change stub holder of KH-A model of NT Tool Co.,Ltd.

Electric system diagram

All the electric parts supplied as standard are indicated in [] box. The purchaser is responsible for and needs to have the other cables and equipment.

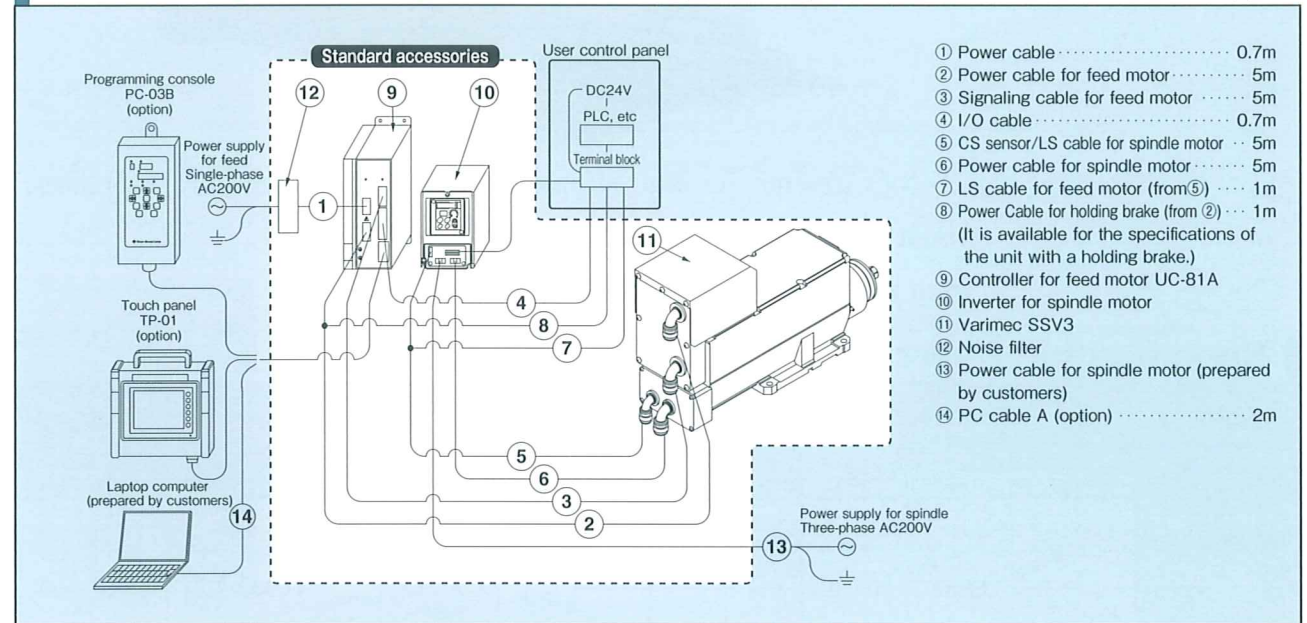

- ① Power cable 0.7m
- ② Power cable for feed motor 5m
- ③ Signaling cable for feed motor 5m
- ④ I/O cable 0.7m
- ⑤ CS sensor/LS cable for spindle motor 5m
- ⑥ Power cable for spindle motor 5m
- ⑦ LS cable for feed motor (from ⑤) 1m
- ⑧ Power cable for holding brake (from ②) 1m (It is available for the specifications of the unit with a holding brake.)
- ⑨ Controller for feed motor UC-81A
- ⑩ Inverter for spindle motor
- ⑪ Varimec SSV3
- ⑫ Noise filter
- ⑬ Power cable for spindle motor (prepared by customers)
- ⑭ PC cable A (option) 2m

- Notes 1. The feed controller and the spindle inverter are standard accessories.
 2. The programming console and touch panel is optionally available. The attached cable is 3m long.
 3. Programming from a computer is possible using a PC cable A. In such case, a dedicated computer monitoring software is required. Working environment: OS Windows 95/98/XP (The mode setting is necessary), Communication interface RS232C-port.

Controller for feed motor UC-81A

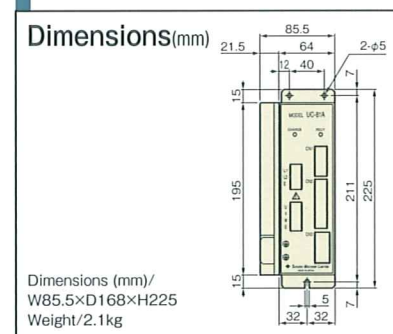

Inverter for spindle motor MVX103BVC

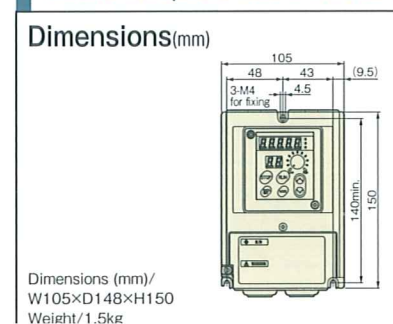

Specification of signal

I/O	Signal	Contents	I/O	Signal	Contents
Analog Output	ORD	Command for spindle speed	#2 Output	OUT0	RDY
	COM	Ground of command for spindle speed		OUT1	Cycle run
	IN0	Emergency stop		OUT2	Program end
	IN1	Manual coolant ON/OFF		OUT3	Origin
	IN2	Power "ON"		OUT4	Spindle ON
	IN3	Machine zero return		OUT5	Ready for single step
	IN4	Single step		OUT6	Coolant ON
	IN5	Spindle alarm		OUT7	Forward side ON
	IN6	JOG+		OUT8	Alarm
#1 Input	IN7	JOG-	※1 Voltage: DC24V, Electric current: 10mA		
	IN8	Forward side OT	※2 Voltage: DC24V, Electric current: 90mA		
	IN9	Backward side OT (Combine with origin LS)			
	NC	No contact terminal			
	IN10	Alarm clear			
	IN11	EXT/MANUAL			
	IN12	Manual spindle ON/OFF			
	IN13	Program 1			
	IN14	Program 2			
	IN15	Program 4			
	IN16	Program 8			
	IN17	Program 10			
IN18	Program 20				
IN19	Program 40				
IN20	Program 80				

Selfeeder Varimec
Selfeeder Mechatric
CNC Turret Head
Data input system / other attachments

Selfeeder Varimec

SSV4

- Linear guide (JP PAT.)
- Multi-spindle heads attachable
- Variable Spindle speed variable type
- Long stroke



Model which has most suitable body structure for doing stepped spot-facing or burnishing drill operations. Also it is possible to do more high-efficient processing when you use this drill unit with multi-spindle heads.

Specification Chart

Model	Specs. Spindle speed (no load)		Chuck type (Collet chuck)	Chuck capacity	Max. Drilling size			Stroke	Spindle motor	Feed motor	Thrust	Rapid approach speed	Cutting speed	Weight
	50Hz	60Hz			AL* (ADC)	FC* (FC200)	ST* (S45C)							
SSV4-2070	1,000~7,000		ER32	1.0~20.0	9	8	7	Max. 250	1.0 DC brushless motor	1.2 AC servo motor	4,600	Max. 220	Max. 16.7	80
SSV4-2017	250~1,750				16	15	13							

- Notes1. To select your model, refer to the workpiece configurations, material, cutting properties, diameter of the hole, and rotation speed.(cutting speed)
 2. The drilling capacity shown above is for a depth equivalent to the drill diameter times two.
 3. The power voltage of the feed controller and main spindle inverter is a 3-phase 200V AC±10%, 50/60Hz.
 4. In the case of a servo motor with a holding brake (optional), add "B" to the end of the model number.
 5. AL*...Aluminium, FC*...Cast Iron, ST*...Steel

Dimensions (mm)

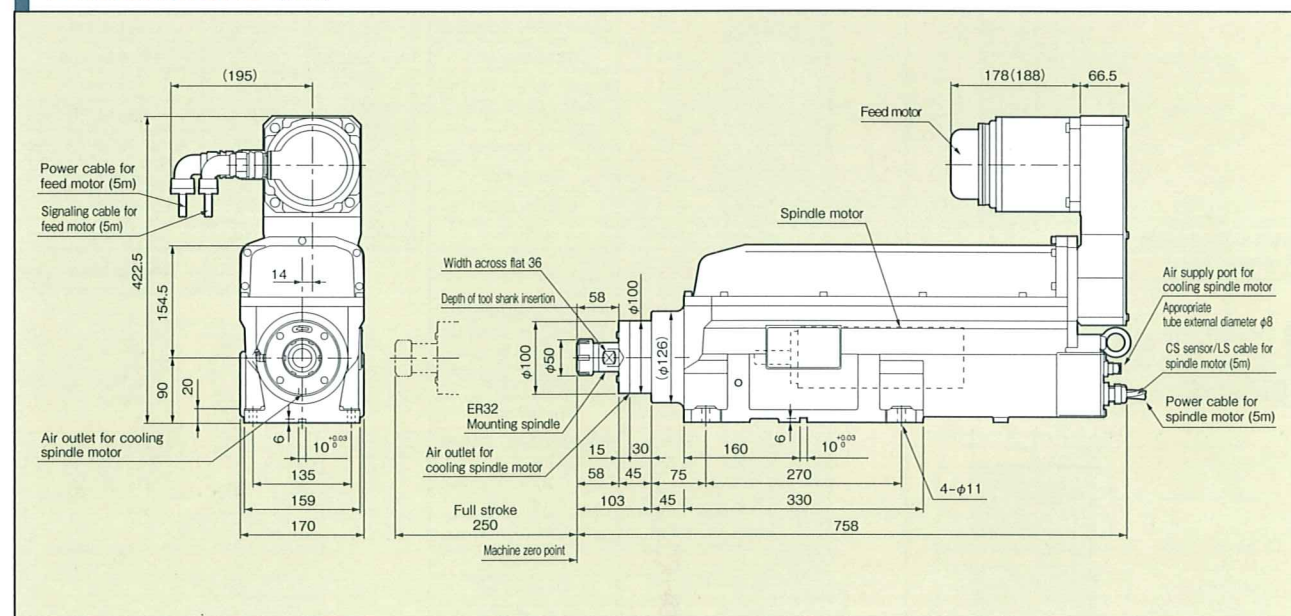

- Notes1. In the case of a servo motor with a holding brake (optional), the dimension of the feed motor is different.
 2. Air must be supplied to cool the spindle motor as to protect the spindle bearings. Be sure to supply clean dry air.

Max. Drilling size (mm)

Aluminium
φ16

Steel
φ13

Adjustable spindle nose (option)

Please specify the adjustable spindle nose when ordering your servo drill. Sugino supplies adjustable spindle noses other than those shown below, upon request.

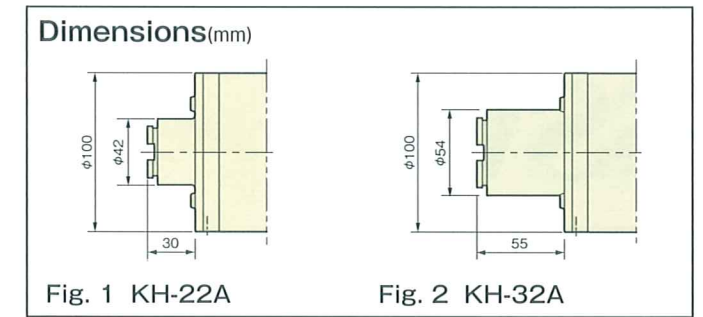

Applicable selfeeder	Fig. No.	Spindle nose model No.
SSV4-2070	1	KH-22A
SSV4-2017	2	KH-32A

Notes: Spindle noses KH-A model is applicable to the quick change stub holder of KH-A model of NT Tool Co.,Ltd.

Electric system diagram

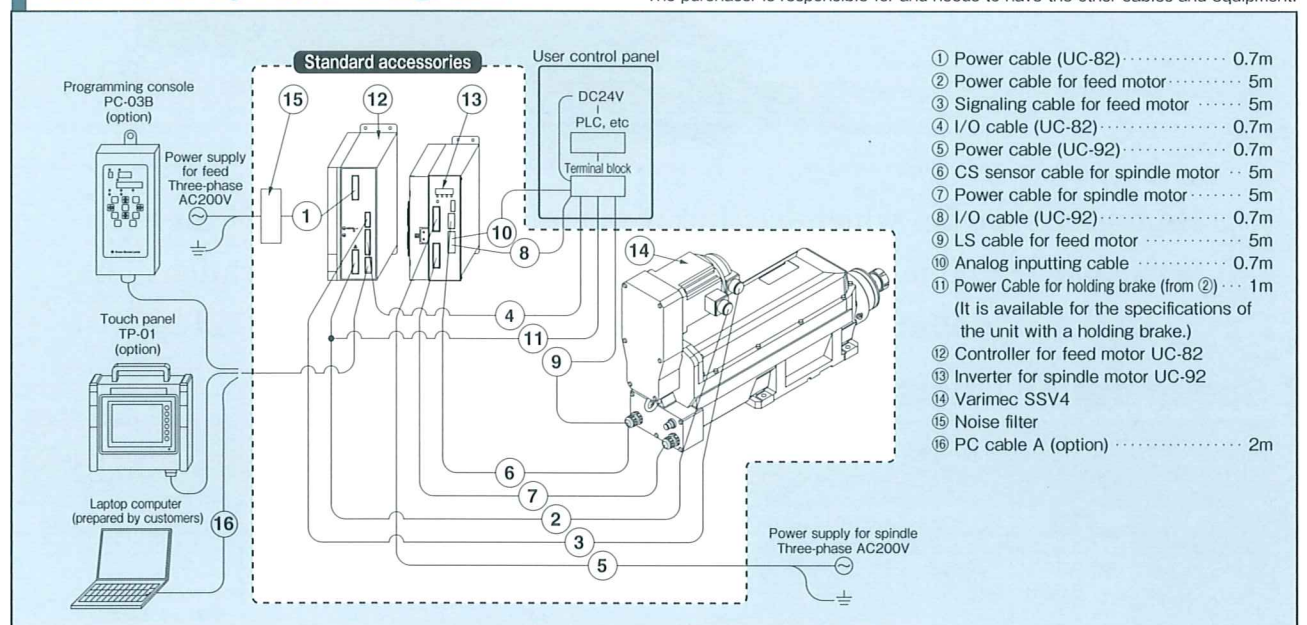

- Notes1. The feed controller and the spindle inverter are standard accessories.
 2. The programming console and touch panel is optionally available. The attached cable is 3m long.
 3. Programming from a computer is possible using a PC cable A. In such case, a dedicated computer monitoring software is required.
 Working environment: OS Windows 95/98/XP (The mode setting is necessary), Communication interface RS232C-port.

All the electric parts supplied as standard are indicated in [] box. The purchaser is responsible for and needs to have the other cables and equipment.

- ① Power cable (UC-82) 0.7m
- ② Power cable for feed motor 5m
- ③ Signaling cable for feed motor 5m
- ④ I/O cable (UC-82) 0.7m
- ⑤ Power cable (UC-92) 0.7m
- ⑥ CS sensor cable for spindle motor 5m
- ⑦ Power cable for spindle motor 5m
- ⑧ I/O cable (UC-92) 0.7m
- ⑨ LS cable for feed motor 5m
- ⑩ Analog inputting cable 0.7m
- ⑪ Power Cable for holding brake (from ②) 1m
(It is available for the specifications of the unit with a holding brake.)
- ⑫ Controller for feed motor UC-82
- ⑬ Inverter for spindle motor UC-92
- ⑭ Varimec SSV4
- ⑮ Noise filter
- ⑯ PC cable A (option) 2m

Controller for feed motor UC-82

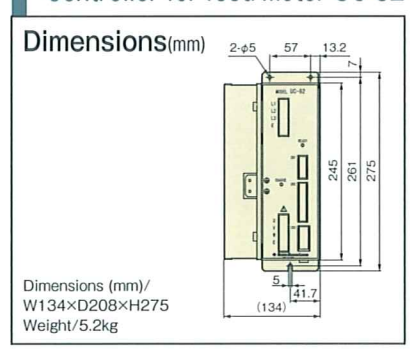

Inverter for spindle motor UC-92

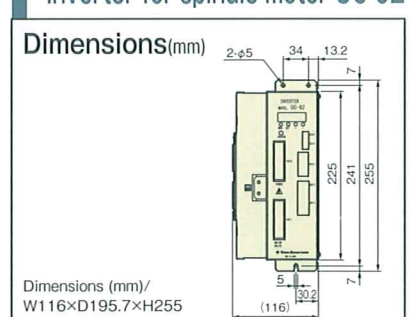

Specification of signal

I/O	Signal	Contents	I/O	Signal	Contents	
Analog Output	ORD	Command for spindle speed	※2 Output	OUT0	RDY	
	COM	Ground of command for spindle speed		OUT1	Cycle run	
	IN0	Emergency stop		OUT2	Program end	
	IN1	Manual coolant ON/OFF		OUT3	Origin	
	IN2	Power "ON"		OUT4	Spindle ON	
	IN3	Machine zero return		OUT5	Ready for single step	
	IN4	Single step		OUT6	Coolant ON	
	IN5	Spindle alarm		OUT7	Forward sideON	
	IN6	JOG+	OUT8	Alarm		
	※1 Input	IN7	JOG-	※1 Voltage: DC24V, Electric current: 10mA		
		IN8	Forward side OT	※2 Voltage: DC24V, Electric current: 90mA		
		IN9	Backward side OT (Combine with origin LS)			
NC		No contact terminal				
IN10		Alarm clear				
IN11		EXT/MANUAL				
IN12		Manual spindle ON/OFF				
IN13		Program 1				
IN14		Program 2				
IN15		Program 4				
IN16	Program 8					
IN17	Program 10					
IN18	Program 20					
IN19	Program 40					

Selfeeder Varimec
Selfeeder Mechatric
CNC Turret Head
Data input system / other attachments

Selfeeder Varimec

SSV5

- Linear guide (JP PAT.)
- Multi-spindle heads attachable
- Spindle speed variable type
- Long stroke
- Large dia. drilling



High-power model which has 1.6kW spindle motor and 7,700N thrust. It is capable of end-mill, facing or 28mm diameter drilling operations into steel material utilizing a unique linear guide system (JP PAT.).

Specification Chart

Specs.	Spindle speed (no load)		Chuck type (Collet chuck)	Chucking capacity	Max. Drilling size			Stroke	Spindle motor	Feed motor	Thrust	Rapid approach speed	Cutting speed	Weight
	50Hz	60Hz			AL* (ADC)	FC* (FC200)	ST* (S45C)							
Model	min ⁻¹		—	mm	mm	mm	mm	mm	kW	kW	N	mm/sec	mm/sec	kg
SSV5-2055	800~5,500		ER32	1.0~20.0	14.5	11.5	9.5	Max. 300	1.6 DC brushless motor	2.7 AC servo motor	7,760	Max. 300	Max. 16.7	100
SSV5-2610	150~1,010		ER40	2.0~26.0	25	20.5	18							

- Notes1. To select your model, refer to the workpiece configurations, material, cutting properties, diameter of the hole, and rotation speed.(cutting speed)
 2. The drilling capacity shown above is for a depth equivalent to the drill diameter times two.
 3. The power voltage of the feed controller and main spindle inverter is a 3-phase 200V AC±10%, 50/60Hz.
 4. In the case of a servo motor with a holding brake (optional), add "B" to the end of the model number.
 5. AL...Aluminium, FC...Cast Iron, ST...Steel

Dimensions (mm)

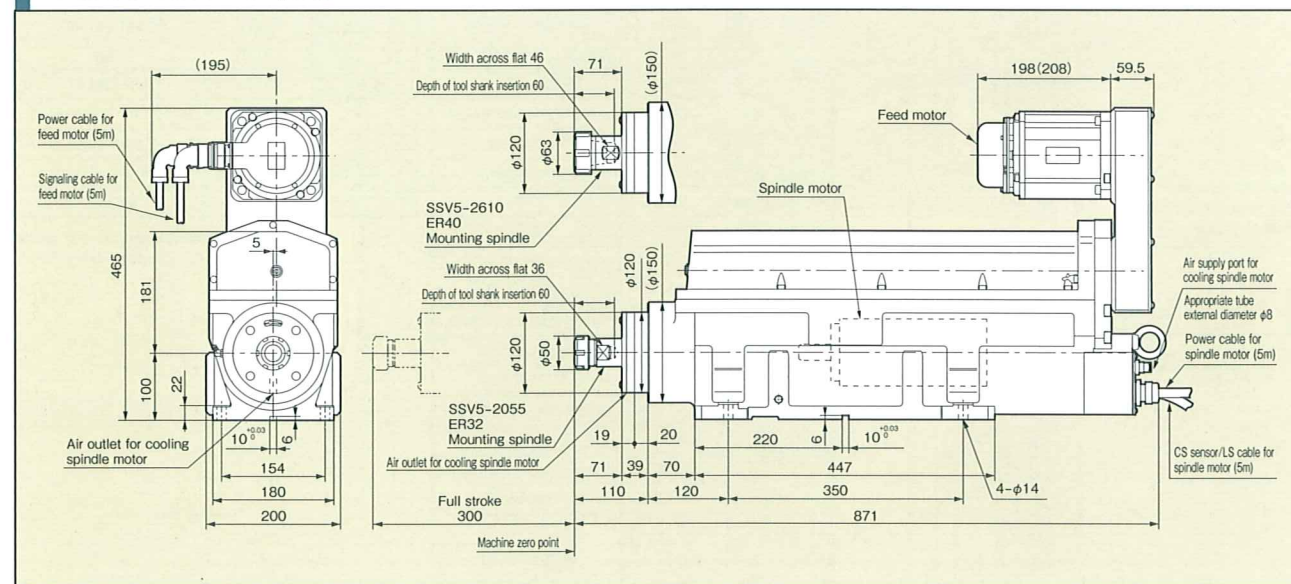

- Notes1. In the case of a servo motor with a holding brake (optional), the dimension of the feed motor is different.
 2. Air must be supplied to cool the spindle motor as to protect the spindle bearings. Be sure to supply clean dry air.

Max. Drilling size (mm)

Aluminum
φ25

Steel
φ18

Adjustable spindle nose (option)

Please specify the adjustable spindle nose when ordering your servo drill. Sugino supplies adjustable spindle noses other than those shown below, upon request.

Applicable selfeeder	Fig. No.	Spindle nose model No.
SSV5-2055	1	KH-32A
SSV5-2610		

Dimensions(mm)

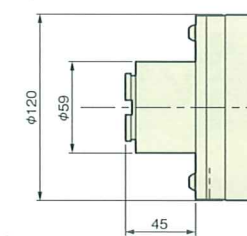
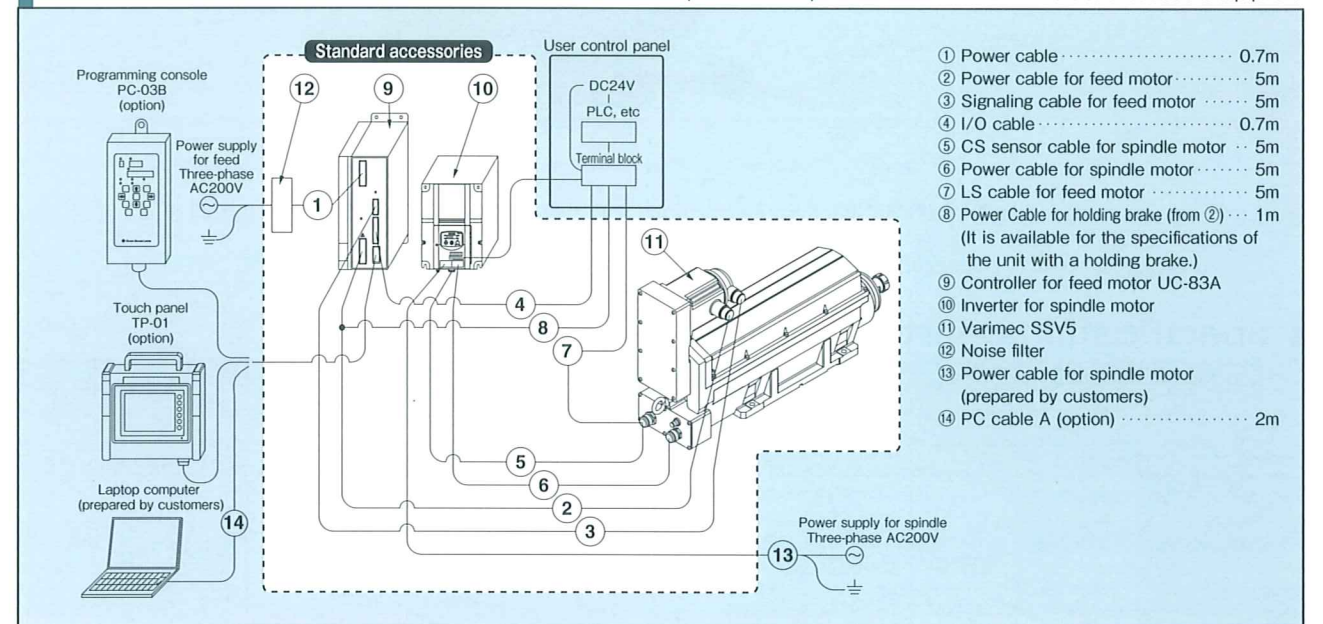

Fig. 1 KH-32A

Notes: Spindle noses KH-A model is applicable to the quick change stub holder of KH-A model of NT Tool Co.,Ltd.

Electric system diagram



All the electric parts supplied as standard are indicated in [] box. The purchaser is responsible for and needs to have the other cables and equipment.

- ① Power cable 0.7m
- ② Power cable for feed motor 5m
- ③ Signaling cable for feed motor 5m
- ④ I/O cable 0.7m
- ⑤ CS sensor cable for spindle motor 5m
- ⑥ Power cable for spindle motor 5m
- ⑦ LS cable for feed motor 5m
- ⑧ Power Cable for holding brake (from ②) 1m
(It is available for the specifications of the unit with a holding brake.)
- ⑨ Controller for feed motor UC-83A
- ⑩ Inverter for spindle motor
- ⑪ Varimec SSV5
- ⑫ Noise filter
- ⑬ Power cable for spindle motor (prepared by customers)
- ⑭ PC cable A (option) 2m

- Notes1. The feed controller and the spindle inverter are standard accessories.
 2. The programming console and touch panel is optionally available. The attached cable is 3m long.
 3. Programming from a computer is possible using a ⑭ PC cable A. In such case, a dedicated computer monitoring software is required.
 Working environment: OS Windows 95/98/XP (The mode setting is necessary), Communication interface RS232C-port.

Controller for feed motor UC-83A

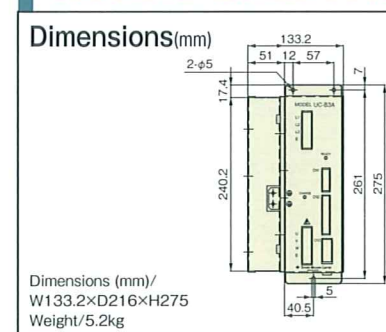

Inverter for spindle motor E100-075LFR2

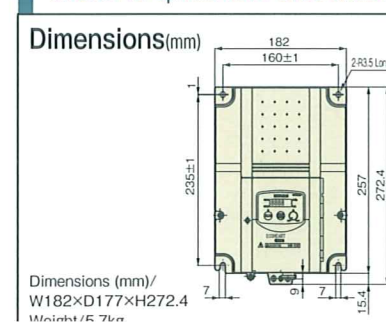

Specification of signal

I/O	Signal	Contents	I/O	Signal	Contents
Analog Output	ORD	Command for spindle speed	※2 Output	OUT0	RDY
	COM	Ground of command for spindle speed		OUT1	Cycle run
※1 Input	IN0	Emergency stop		OUT2	Program end
	IN1	Manual coolant ON/OFF		OUT3	Origin
	IN2	Power "ON"		OUT4	Spindle ON
	IN3	Machine zero return		OUT5	Ready for single step
	IN4	Single step		OUT6	Coolant ON
	IN5	Spindle alarm		OUT7	Forward side ON
	IN6	JOG+	OUT8	Alarm	
	IN7	JOG-			
	IN8	Forward side OT			
	IN9	Backward side OT (Combine with origin LS)			
NC	No contact terminal				
IN10	Alarm clear				
IN11	EXT/MANUAL				
IN12	Manual spindle ON/OFF				
IN13	Program 1				
IN14	Program 2				
IN15	Program 4				
IN16	Program 8				
IN17	Program 10				
IN18	Program 20				
IN19	Program 40				

- ※1 Voltage: DC24V, Electric current: 10mA
 ※2 Voltage: DC24V, Electric current: 90mA

Selfeeder Varimec
Selfeeder Mechatronic
CNC Turret Head
Data input system / other attachments

Selfeeder Mechatric

SSM4

- Multi-spindle heads attachable
- Variable Spindle speed variable type
- Small dia. and deep hole drilling
- Coolant center-through



Max. Drilling size (mm)

Aluminium
φ16

Steel
φ11

Most suitable unit for doing small diameter and deep hole drilling. The spindle rotation speed is easily adjusted in the program.

It can utilize coolant center-through tooling specification as an option for doing more high-efficient processing.

Specification Chart

Model	Specs.		Chuck type (Collet chuck)	Chucking capacity mm	Max. Drilling size			Stroke mm	Spindle motor kW	Feed motor kW	Thrust N	Rapid approach speed mm/sec	Cutting speed mm/sec	Weight kg
	Spindle speed (no load)	50Hz			60Hz	AL* (ADC)	FC* (FC200)							
SSM4-1673	1,470~7,320		ER25	0.5~16	6	5	4	Max. 150	0.75 DC brushless motor Rated speed 3,600min ⁻¹	0.4 AC servo motor	2,320	Max. 150	Max. 16.7	60
SSM4-1636	720~3,600				8	7	6		0.75 DC brushless motor Rated speed 1,800min ⁻¹					
SSM4-1618	360~1,800				11	9	8							
SSM4-1608	180~880				16	12	11							

- Notes1. To select your model, refer to the workpiece configurations, material, cutting properties, diameter of the hole, and rotation speed.(cutting speed)
 2. The drilling capacity shown above is for a depth equivalent to the drill diameter times two.
 3. The power voltage of the main spindle inverter is a 3-phase 200V AC±10%, 50/60Hz. (Feeding axis controller is single-phase.)
 4. In the case of a servo motor with a holding brake (optional), add "B" to the end of the model number.
 5. "CL" is added to the end of model No. for coolant center-through specification.
 6. AL*...Aluminium, FC*...Cast Iron, ST*...Steel

Dimensions (mm)

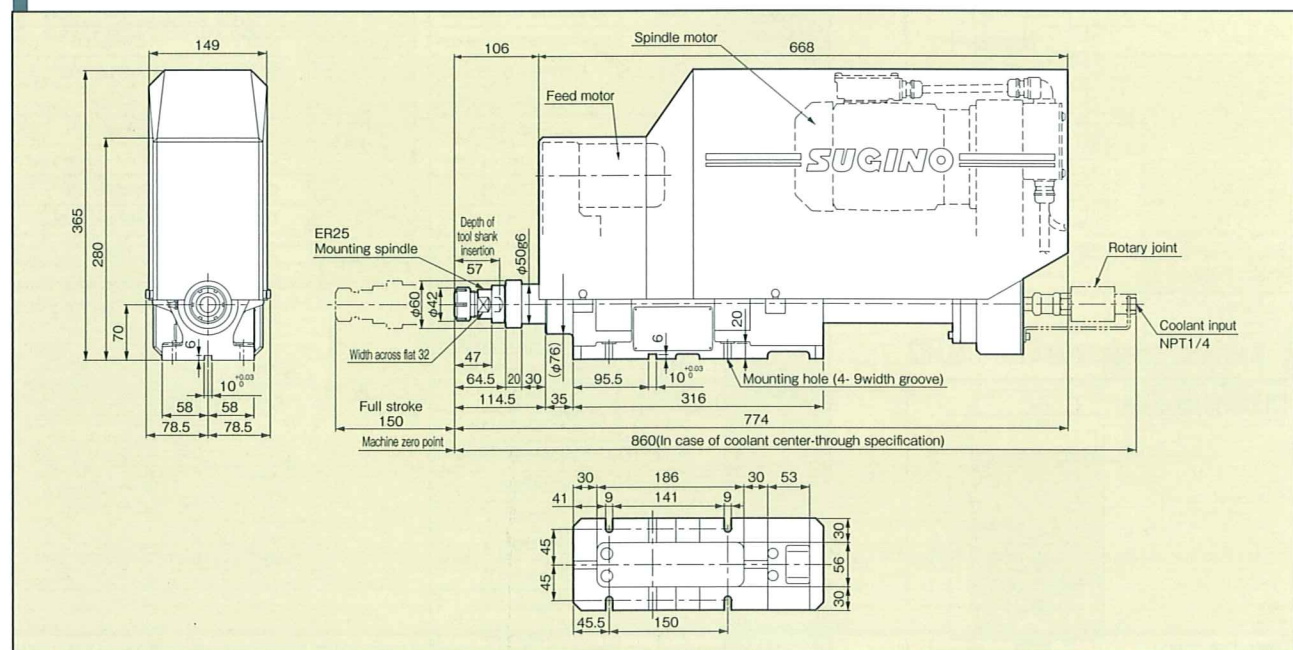

Note: Rotary joint is included in the standard supply for coolant center-through specification.

Adjustable spindle nose (option)

Please specify the adjustable spindle nose when ordering your servo drill.

Sugino supplies adjustable spindle noses other than those shown below, upon request.

Applicable selfeeder	Fig. No.	Spindle nose model No.
SSM4-1673, SSM4-1636	1	KH-16A
SSM4-1618, SSM4-1608	2	KH-22A

Dimensions(mm)

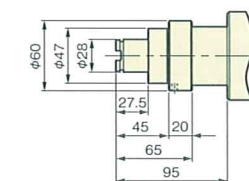

Fig. 1 KH-16A

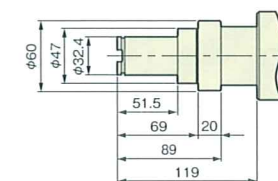
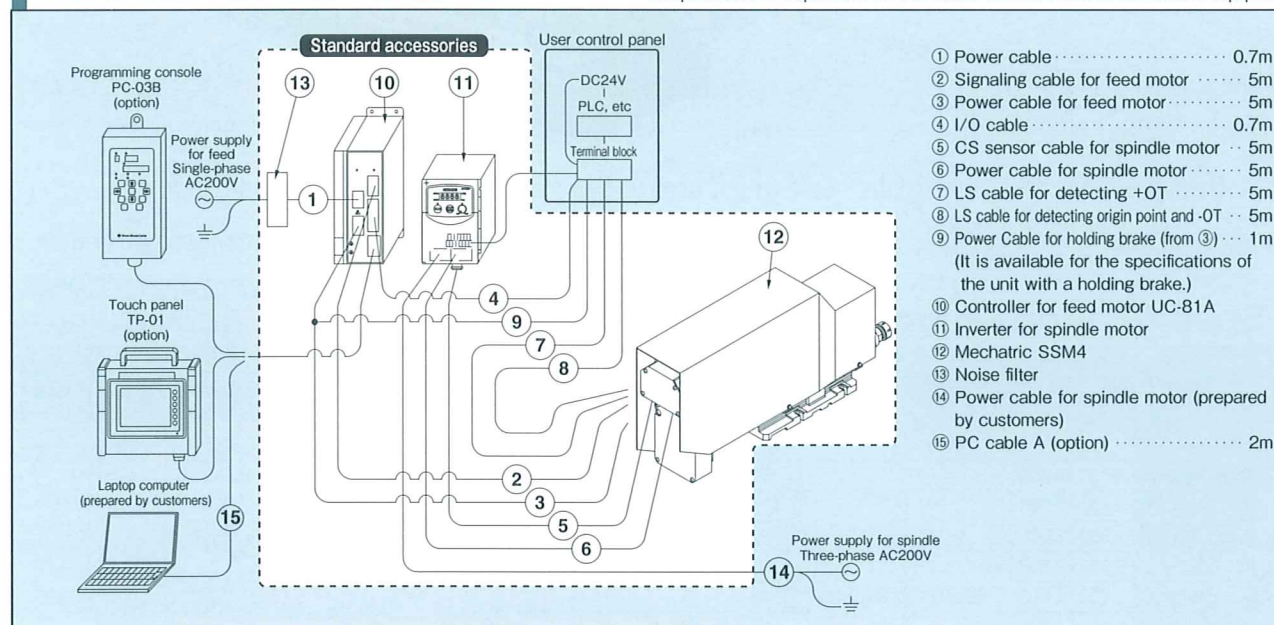

Fig. 2 KH-22A

Notes: Spindle noses KH-A model is applicable to the quick change stub holder of KH-A model of NT Tool Co., Ltd.

Electric system diagram

All the electric parts supplied as standard are indicated in [] box. The purchaser is responsible for and needs to have the other cables and equipment.



- ① Power cable 0.7m
- ② Signaling cable for feed motor 5m
- ③ Power cable for feed motor 5m
- ④ I/O cable 0.7m
- ⑤ CS sensor cable for spindle motor 5m
- ⑥ Power cable for spindle motor 5m
- ⑦ LS cable for detecting +OT 5m
- ⑧ LS cable for detecting origin point and -OT 5m
- ⑨ Power Cable for holding brake (from ③) 1m
(It is available for the specifications of the unit with a holding brake.)
- ⑩ Controller for feed motor UC-81A
- ⑪ Inverter for spindle motor
- ⑫ Mechatric SSM4
- ⑬ Noise filter
- ⑭ Power cable for spindle motor (prepared by customers)
- ⑮ PC cable A (option) 2m

- Notes1. The feed controller and the spindle inverter are standard accessories.
 2. The programming console and touch panel is optionally available. The attached cable is 3m long.
 3. Programming from a computer is possible using a ⑮ PC cable A. In such case, a dedicated computer monitoring software is required.
 Working environment: OS Windows 95/98/XP (The mode setting is necessary), Communication interface RS232C-port.

Controller for feed motor UC-81A

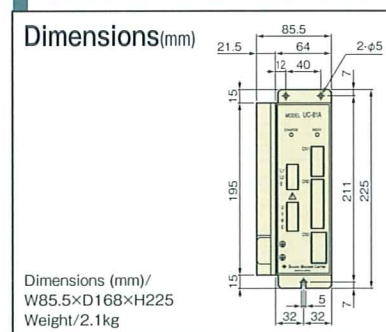

Dimensions (mm)/
W85.5×D106×H225
Weight/2.1kg

Inverter for spindle motor E100-007LFR2

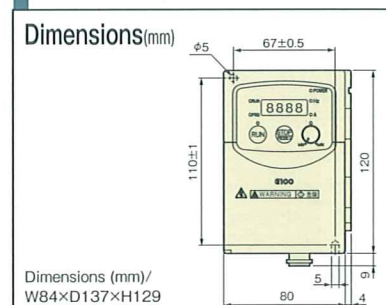

Dimensions (mm)/
W84×D137×H129
Weight/0.9kg

Specification of signal

I/O	Signal	Contents	I/O	Signal	Contents
Analog Output	ORD	Command for spindle speed	※2 Output	OUT0	RDY
	COM	Ground of command for spindle speed		OUT1	Cycle run
※1 Input	IN0	Emergency stop		OUT2	Program end
	IN1	Manual coolant ON/OFF		OUT3	Origin
	IN2	Power "ON"		OUT4	Spindle ON
	IN3	Machine zero return		OUT5	Ready for single step
	IN4	Single step		OUT6	Coolant ON
	IN5	Spindle alarm		OUT7	Forward sideON
	IN6	JOG+	OUT8	Alarm	
	IN7	JOG-			
	IN8	Forward side OT			
	IN9	Backward side OT (Combine with origin LS)			
	IN10	NC No contact terminal			
	IN11	Alarm clear			
	IN12	Manual spindle ON/OFF			
	IN13	Program 1			
	IN14	Program 2			
IN15	Program 4				
IN16	Program 8				
IN17	Program 10				
IN18	Program 20				
IN19	Program 40				

※1 Voltage: DC24V, Electric current: 10mA
 ※2 Voltage: DC24V, Electric current: 90mA

Selffeeder Mechatric

SSM5

- Long stroke
- Small dia. and deep hole drilling
- Large dia. drilling
- Coolant center-through
- Linear guide

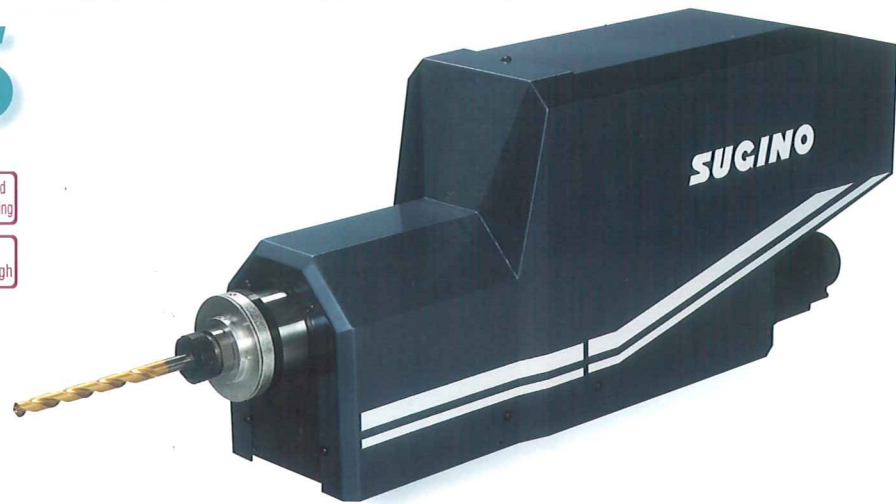

High-precision and high-rigidity unit which uses united structure of spindle unit and slide table. It offers high-efficient deep hole drilling because of 300mm long stroke and coolant center-through system.

Specification Chart

Specs.	Spindle speed (no load)		Chuck type (Collet chuck)	Chucking capacity mm	Max. Drilling size			Stroke mm	Spindle motor kW	Feed motor kW	Thrust N	Rapid approach speed mm/sec	Cutting speed mm/sec	Weight kg
	50Hz	60Hz			AL* (ADC)	FC* (FC200)	ST* (S45C)							
Model	min ⁻¹		—	mm	mm	mm	mm	mm	kW	kW	N	mm/sec	mm/sec	kg
SSM5-2641BCL	4,100	4,900	ER40	Max.26	8	4	4	Max. 300	2.2 Induction motor	2.7 AC servo motor	5,000	Max. 300	Max. 16.7	230
SSM5-2634BCL	3,400	4,000			9	5	5							
SSM5-2625BCL	2,500	3,000			12	6	6							
SSM5-2621BCL	2,100	2,500			10	5	5							
SSM5-2617BCL	1,700	2,000			12	6	6							
SSM5-2611BCL	1,100	1,300			16	9	8							
SSM5-2607BCL	700	850			19	14	12.5							
SSM5-2604BCL	400	480			19	15	13.5							
SSM5-2602BCL	220	260			24	21	19		0.75 Induction motor					

- Notes1. To select your model, refer to the workpiece configurations, material, cutting properties, diameter of the hole, and rotation speed.(cutting speed)
 2. The drilling capacity shown above is for a depth equivalent to the drill diameter times two.
 3. The power voltage of the feed controller and main spindle inverter is a 3-phase 200V AC±10%, 50/60Hz.
 4. Holding brake is attached to the feed motor.
 5. Coolant center-through is used for SSM5 as standard specification. Please direct if you do not need it.
 6. AL*...Aluminium, FC*...Cast Iron, ST*...Steel

Dimensions (mm)

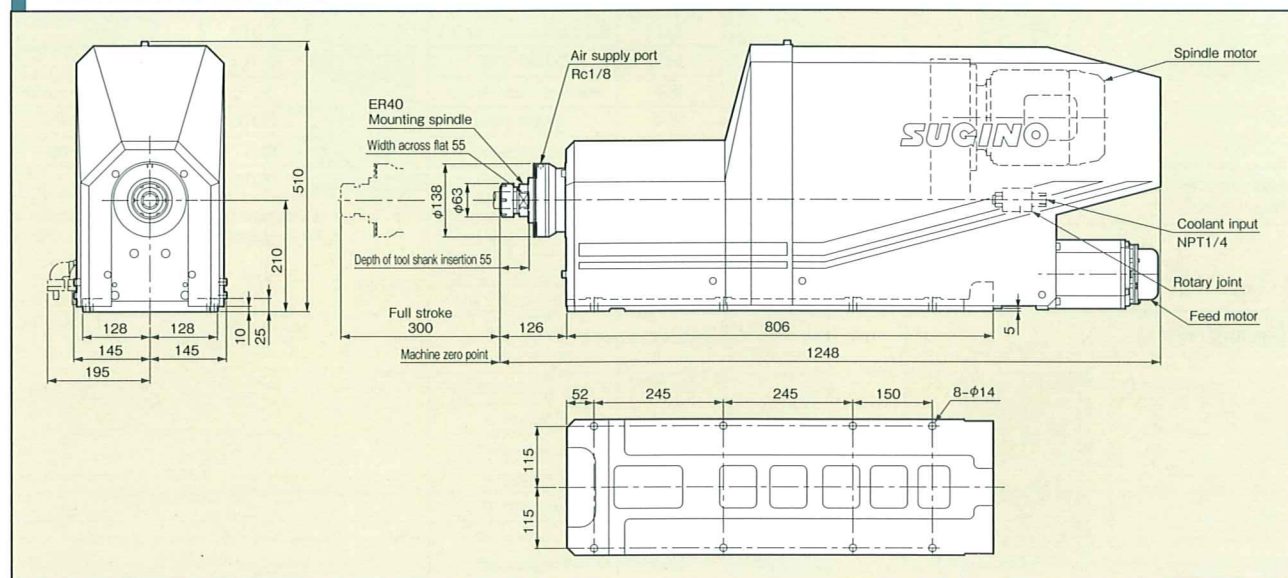

Note: Rotary joint attaches to SSM5 as standard.

Adjustable spindle nose (option)

Please specify the adjustable spindle nose when ordering your servo drill.

Sugino supplies adjustable spindle noses other than those shown below, upon request.

Dimensions(mm)

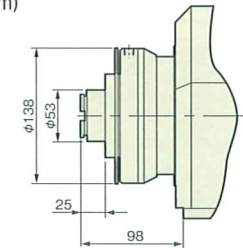

Fig. 1 KH-32EC

Notes: Spindle noses KH-EC model is applicable to the quick change stub holder of KH-EC model of NT Tool Co., Ltd.

Applicable selffeeder	Fig. No.	Spindle nose model No.
SSM5-26**BCL	1	KH-32EC

Electric system diagram

All the electric parts supplied as standard are indicated in [] box. The purchaser is responsible for and needs to have the other cables and equipment.

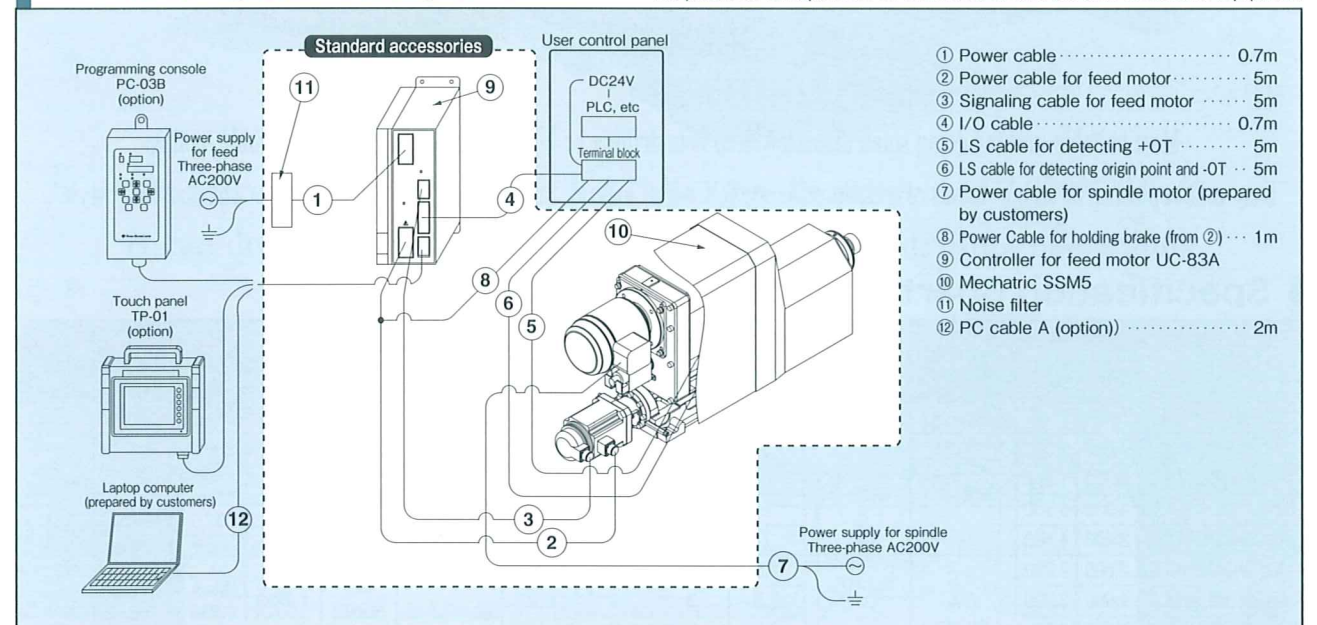

- ① Power cable 0.7m
- ② Power cable for feed motor 5m
- ③ Signaling cable for feed motor 5m
- ④ I/O cable 0.7m
- ⑤ LS cable for detecting +OT 5m
- ⑥ LS cable for detecting origin point and -OT 5m
- ⑦ Power cable for spindle motor (prepared by customers)
- ⑧ Power Cable for holding brake (from ②) 1m
- ⑨ Controller for feed motor UC-83A
- ⑩ Mechatric SSM5
- ⑪ Noise filter
- ⑫ PC cable A (option) 2m

- Notes1. The feed controller is standard accessories.
 2. The programming console and touch panel is optionally available. The attached cable is 3m long.
 3. Programming from a computer is possible using a ⑫ PC cable A. In such case, a dedicated computer monitoring software is required.
 Working environment: OS Windows 95/98/XP (The mode setting is necessary), Communication interface RS232C-port.

Controller for feed motor UC-83A

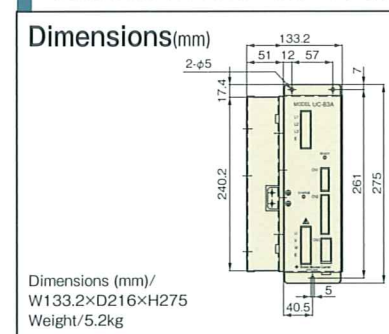

Specification of signal

I/O	Signal	Contents	I/O	Signal	Contents
※1 Input	IN0	Emergency stop	※2 Output	OUT0	RDY
	IN1	Manual coolant ON/OFF		OUT1	Cycle run
	IN2	Power "ON"		OUT2	Program end
	IN3	Machine zero return		OUT3	Origin
	IN4	Single step		OUT4	Spindle ON
	IN5	Spindle alarm		OUT5	Ready for single step
	IN6	JOG+		OUT6	Coolant ON
	IN7	JOG-		OUT7	Forward sideON
	IN8	Forward side OT	OUT8	Alarm	
	IN9	Backward side OT (Combine with origin LS)			
	IN10	No contact terminal			
	IN11	Alarm clear			
IN12	EXT/MANUAL				
IN13	Program 1				
IN14	Program 2				
IN15	Program 4				
IN16	Program 8				
IN17	Program 10				
IN18	Program 20				
IN19	Program 40				
IN20	Program 80				

- ※1 Voltage: DC24V, Electric current: 10mA
- ※2 Voltage: DC24V, Electric current: 90mA

Max. Drilling size (mm)

Aluminium
φ24

Steel
φ19

Selffeeder Varimec

Selffeeder Mechatric

CNC Turret Head

Data input system /
other attachments

Selfeeder Mechatric

MS3P

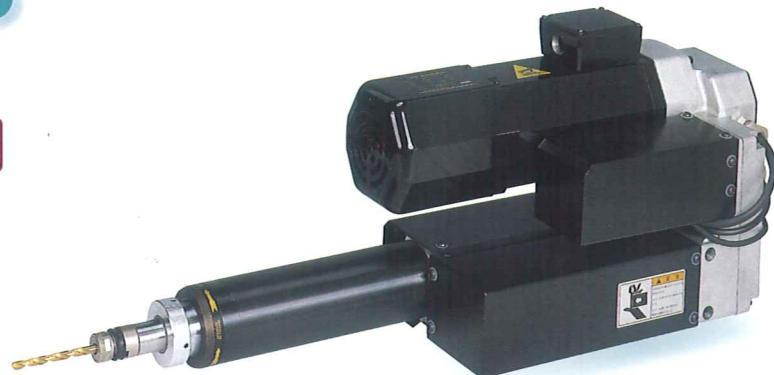
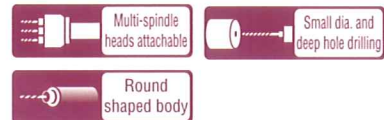

Most suitable unit for doing small diameter/deep hole drilling or high-precision drilling with carbide tooling.

Easy unit replacement on operations originally utilizing Selfeeder "Electric" types because it uses the same "circular body style".

Specification Chart

Model	Specs.		Chuck type (Collet chuck)	Chucking capacity mm	Max. Drilling size			Stroke mm	Spindle motor kW	Feed motor kW	Thrust N	Rapid approach speed mm/sec	Cutting speed mm/sec	Weight kg
	Spindle speed (no load)	50Hz			60Hz	AL* (ADC)	FC* (FC200)							
MS3P-3075LLZ	7,500	9,000	ER11	0.5~7	3	1.5	1.5	150	0.35 2P Induction motor	0.4 AC servo motor	1,760	Max. 200	Max. 16.7	34
MS3P-3060LLZ	6,000	7,200			4	1.5	1.5							
MS3P-6049LLZ	4,900	5,900			5	2	2							
MS3P-6034LLZ	3,400	4,100			7	3	3							
MS3P-1326LLZ	2,600	3,200	ER20	0.5~13	7.5	3.5	3.5		0.35 6P Induction motor					
MS3P-1318LLZ	1,800	2,200			8.5	5	4							
MS3P-1314LLZ	1,400	1,700			9.5	6	6							
MS3P-1310LLZ	1,000	1,200			10	8	7							
MS3P-1307LLZ	700	800			12	9	8							
MS3P-1306LLZ	600	700			13.5	10.5	9							
MS3P-1305LLZ	500	600	14	12	10	35								

- Notes1. To select your model, refer to the workpiece configurations, material, cutting properties, diameter of the hole, and rotation speed.(cutting speed)
 2. The drilling capacity shown above is for a depth equivalent to the drill diameter times two.
 3. The power voltage of the main spindle motor is a 3-phase 200V AC±10%, 50/60Hz. (Feeding axis controller is single-phase.)
 4. In the case of a servo motor with a holding brake (optional), add "B" to the end of the model number.
 5. AL*...Aluminium, FC*...Cast Iron, ST*...Steel

Dimensions (mm)

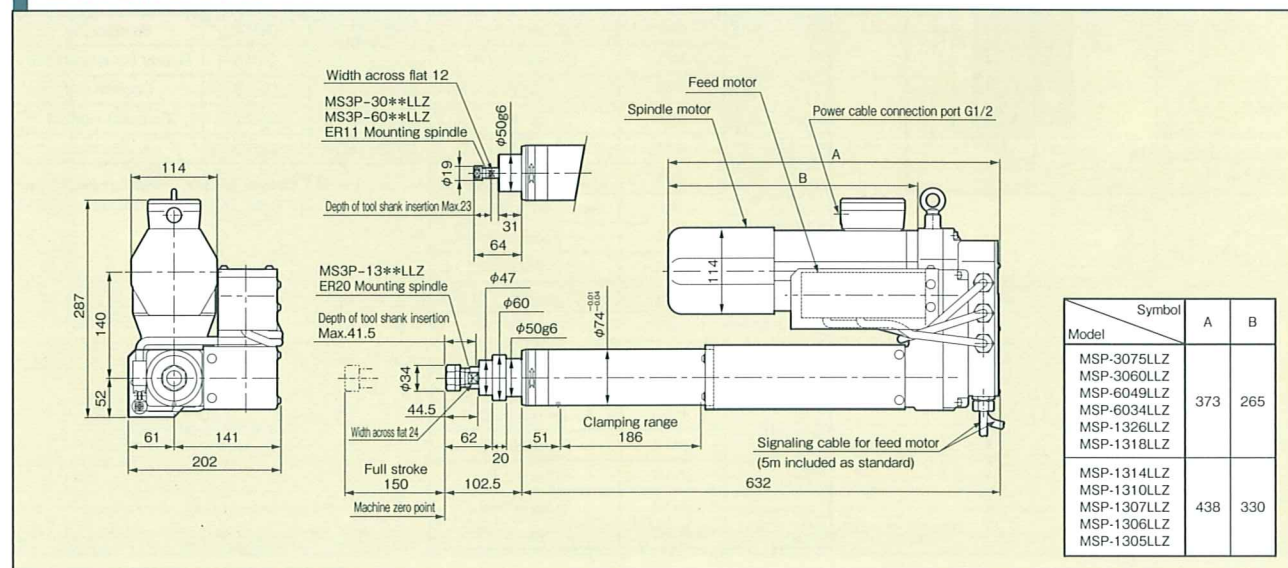

Max. Drilling size (mm)

Aluminium
φ14

Steel
φ10

Selfeeder Mechatric

MS7

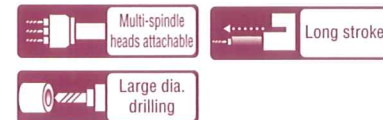

High-power model which has a 3.7kW spindle motor and 7,800N thrust.

It can do facing, end-milling and 28mm diameter drilling operations into steel material.

Specification Chart

Model	Specs.		Chuck type (Collet chuck)	Chucking capacity mm	Max. Drilling size			Stroke mm	Spindle motor kW	Feed motor kW	Thrust N	Rapid approach speed mm/sec	Cutting speed mm/sec	Weight kg
	Spindle speed (no load)	50Hz			60Hz	AL* (ADC)	FC* (FC200)							
MS7-3229	2,900	3,500	ER32	1.0~20	11	4	3	200	3.7 4P Induction motor	2.7 AC servo motor	7,800	Max. 298	Max. 16.7	270
MS7-3222	2,200	2,700			13	5	4							
MS7-3215	1,500	1,800			17	7	6							
MS7-3210	1,000	1,200			20	14	12							
MS7-3206	650	800			25	19	16	2.2 6P Induction motor						
MS7-3205	500	600			31	24	21							
MS7-3203	340	410			40	32	28							

- Notes1. To select your model, refer to the workpiece configurations, material, cutting properties, diameter of the hole, and rotation speed.(cutting speed)
 2. The drilling capacity shown above is for a depth equivalent to the drill diameter times two.
 3. The power voltage of the feed controller and main spindle motor is a 3-phase 200V AC±10%, 50/60Hz.
 4. In the case of a servo motor with a holding brake (optional), add "B" to the end of the model number.
 5. AL*...Aluminium, FC*...Cast Iron, ST*...Steel

Dimensions (mm)

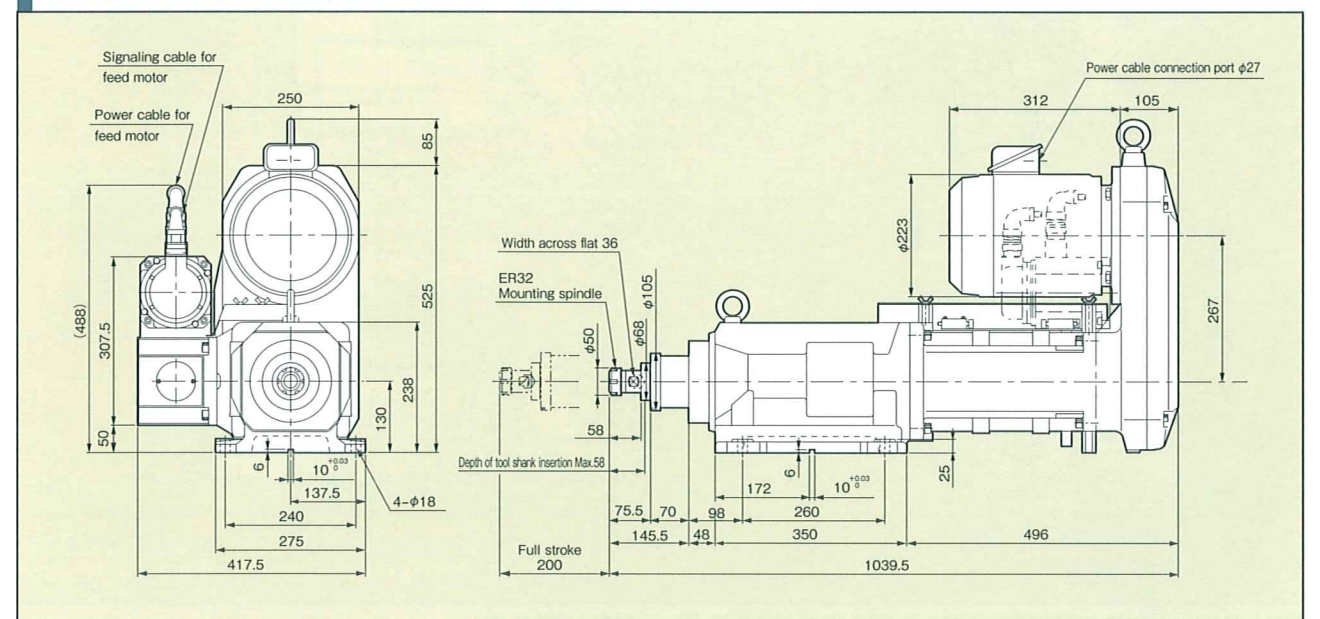

CNC Turret Head

4TH3S

- Linear guide (JP PAT.)
- Compact
- Variable Spindle speed variable type
- 4-spindle Turret



Max. Drilling size (mm)

Aluminium
φ12

Steel
φ8

Compact sized turret which uses a Selfeeder "Varimec" as a drive unit. It has a tool change function so 1 machine can do 4 types of operations.

Also it is useful for using by "automatic drilling machine style with tool change system".

Specification Chart

Specs.	Spindle speed (no load)		Chuck type (Collet chuck)	Chucking capacity mm	Max. Drilling size			Stroke mm	Spindle motor kW	Feed motor kW	Thrust N	Rapid approach speed mm/sec	Cutting speed mm/sec	Indexing time		Weight kg		
	50Hz	60Hz			AL* (ADC)	FC* (FC200)	ST* (S45C)							50Hz	60Hz			
4TH3S + SSV3-7100THB	1,000~7,000		Stub holder [KH-20E] [NT tool]	2.6~9.0	6.5	5	4	Max. 200	0.4 DC brushless motor	0.4 AC servo motor	1,660	Max. 200	Max. 16.7	0.9	0.8	73		
4TH3S + SSV3-1626THB	265~2,650				12	9	8											
4TH3S + SSV4-2070THB	1,000~7,000				9	8	7	Max. 250	1.0 DC brushless motor	1.2 AC servo motor	4,600	Max. 220						110

- Notes1. To select your model, refer to the workpiece configurations, material, cutting properties, diameter of the hole, and rotation speed.(cutting speed)
 2. The drilling capacity shown above is for a depth equivalent to the drill diameter times two.
 3. Indexing time is the time for turret rotation. It does not including the time of spindle start and stop.
 4. When you install this turret head into SSV3-7100THB, please set "under 7,000min⁻¹" for spindle rotation speed.
 5. Holding brake is attached to the feed motor.
 6. AL*...Aluminium, FC*...Cast Iron, ST*...Steel

Dimensions (mm)

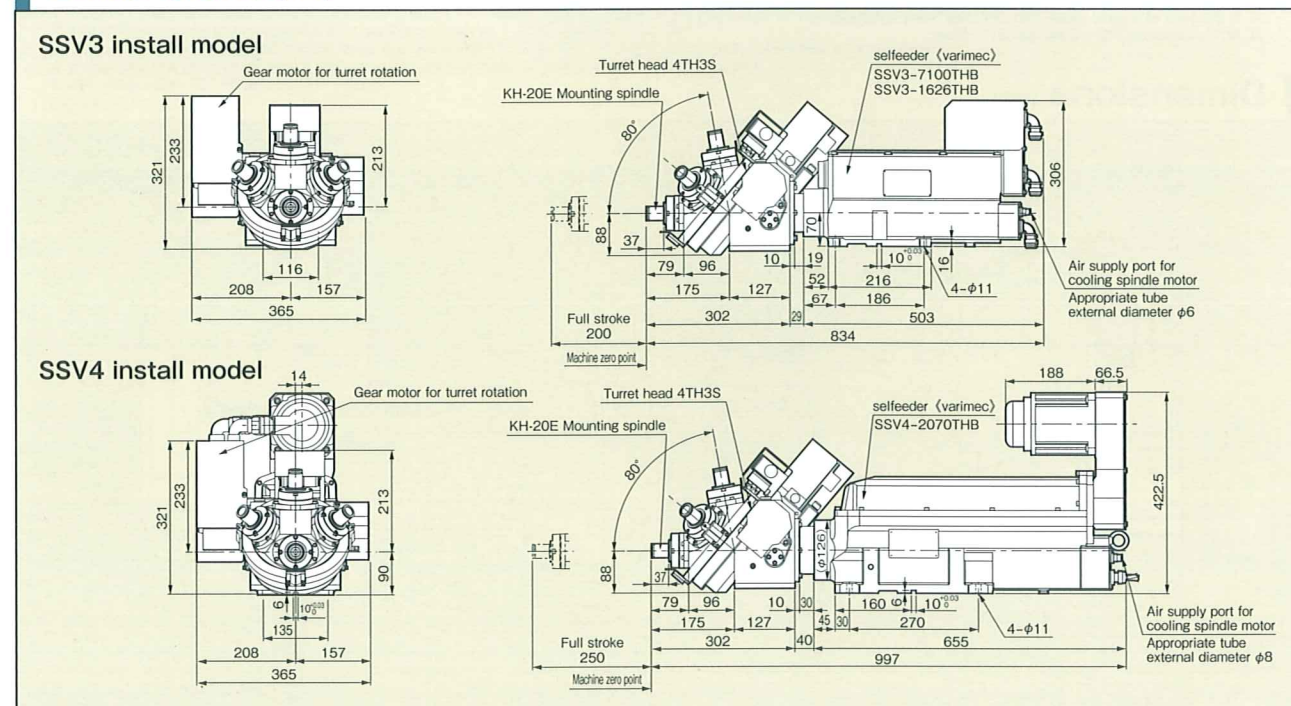

Note: Air must be supplied to cool the spindle motor as to protect the spindle bearings. Be sure to supply clean dry air.

Electric system diagram

All the electric parts supplied as standard are indicated in [] box. The purchaser is responsible for and needs to have the other cables and equipment.

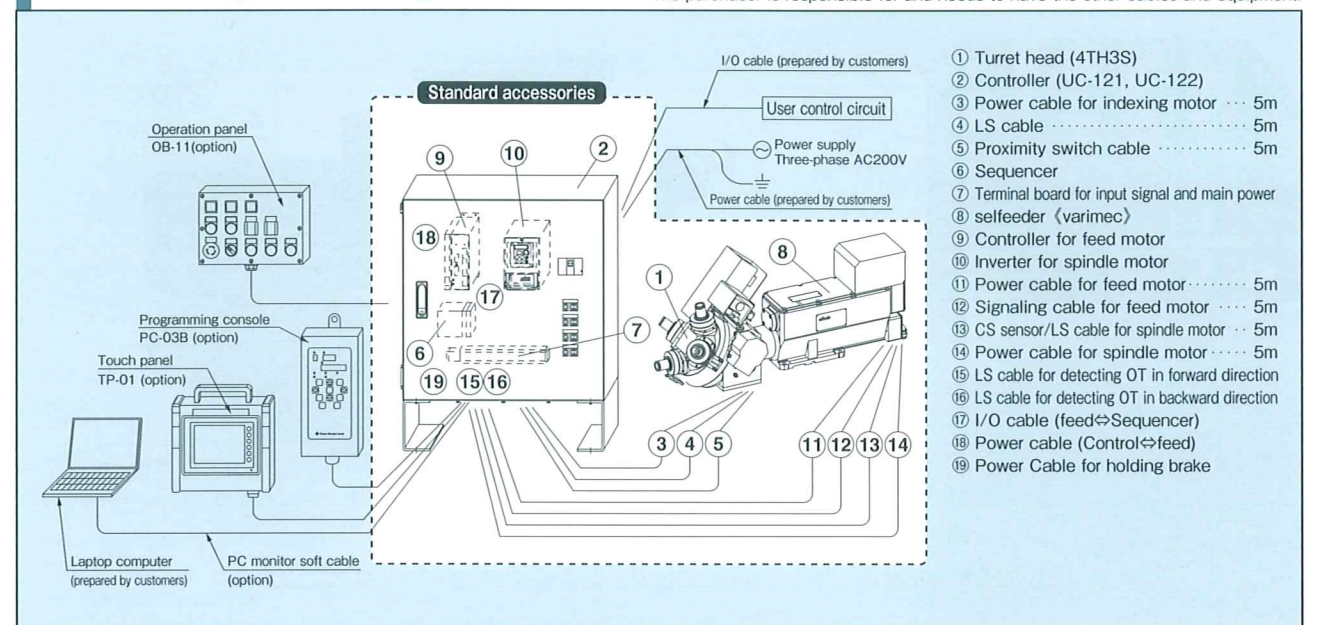

- Notes1. Operation panel, the programming console and touch panel is optionally available. The attached cable is 3m long.
 2. Programming from a computer is possible using a PC monitor soft cable. In such case, a dedicated computer monitoring software is required.
 Working environment: OS Windows 95/98/XP (The mode setting is necessary), Communication interface RS232C-port.
 3. Turret rotation can operate from operation panel only. It is impossible for doing turret rotation from programming console, pouch panel and PC monitor software.

Operation panel and Controller

Dimensions(mm)

Operation panel OB-11 Controller UC-121 (for SSV3) UC-122 (for SSV4)

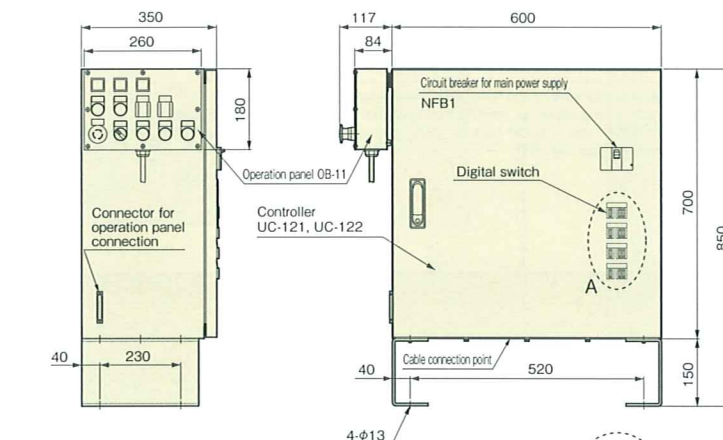

Specification of signal

I/O	Signal	Contents
※1 Input	X110	Power "ON"
	X111	Machine zero return
	X112	Emergency stop
	X113	Alarm clear
	X114	Selfeeder ON
	X115	Turret Indexing
	X116	Spare
※2 Output	Y50	All origin position
	Y51	Selfeeder Origin
	Y52	Turret cam Origin
	Y53	Program end
	Y54	Alarm
	Y55	Run
	Y56	Spare
Power	+24V	External I/O power DC24V
	0V	External I/O power 0V

- ※1 Voltage: DC24V±10%, Electric current: less or equal 7mA
 ※2 Voltage: DC24V, Electric current: less or equal 100mA

Application



CNC Turret Head

4TH5

- Linear guide
- Variable Spindle speed variable type
- 4-spindle Turret
- Rigid tapping

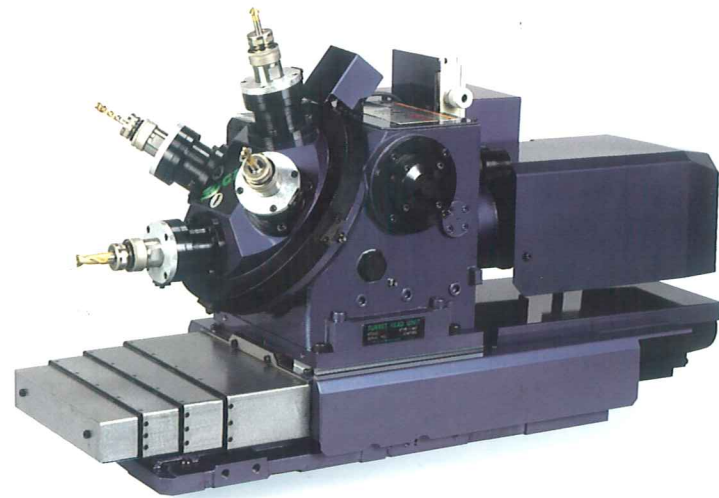

Designed to integrate onto space-saving and high-efficient production machines, the versatile it can combine plural kinds of process like facing, drilling, chamfering, tapping and other kinds of processing.

Specification Chart

Specs.	Spindle speed (no load)		Chuck type (Collet chuck)	Chucking capacity	Max. Drilling/Tapping size			Stroke	Spindle motor	Feed motor	Thrust	Rapid approach speed		Indexing time	Weight						
	50Hz	60Hz			AL* (ADC)	FC* (FC200)	ST* (S45C)					50Hz	60Hz								
Model	min ⁻¹		—	mm	mm	mm	mm	mm	kW	kW	N	mm/sec	sec	sec	kg						
4TH5-1660	Max.6,000		Stub holder [KH-25E NT tool]	3.6~16.0	14	11	9.5	Max. 200	2.0 AC servo motor	1.2 AC servo motor	Max. 1,960	Max. 500	1.2	1.0	260						
		M10			M8	M8															
4TH5-1612	Max.1,200				M20	M15	M13												1.5	1.2	280
			M16	M12	M12																

Notes1. To select your model, refer to the workpiece configurations, material, cutting properties, diameter of the hole, and rotation speed.(cutting speed)
 2. The upper row of the maximum drilling/tapping capacity section shows the maximum drilling capacity. And lower row shows the maximum tapping capacity.
 3. The drilling capacity shown above is for a depth equivalent to the drill diameter times two. A spiral type or point type tapping tool is used for the tapping capacity section.
 Tapping capacities are conditional on the depth of tapping being limited to 1.5 times the tap diameter.
 4. Holding brake is attached to the feed motor.
 5. AL*...Aluminium, FC*...Cast Iron, ST*...Steel

Dimensions (mm)

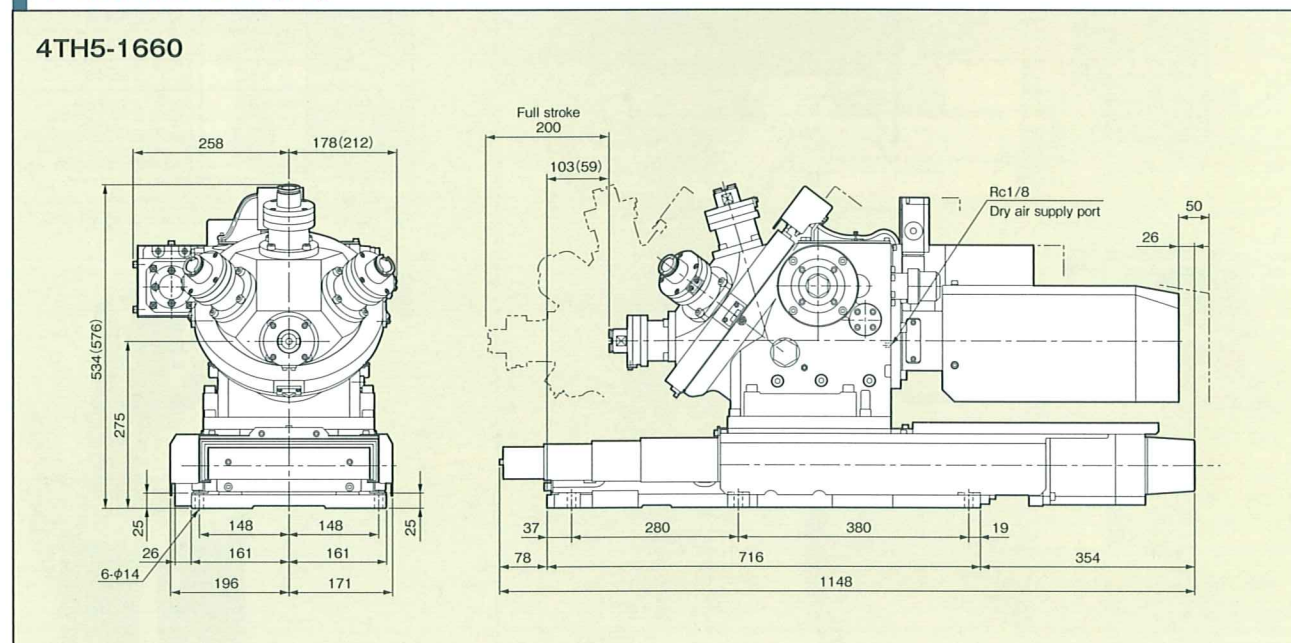

Note1. For protecting the inside structure, please input dry air for air-purge from Rc1/8.
 2. Parenthesized numbers are showing the dimensions of 4TH5-1612.

Electric system diagram

All the electric parts supplied as standard are indicated in [] box. The purchaser is responsible for and needs to have the other cables and equipment.

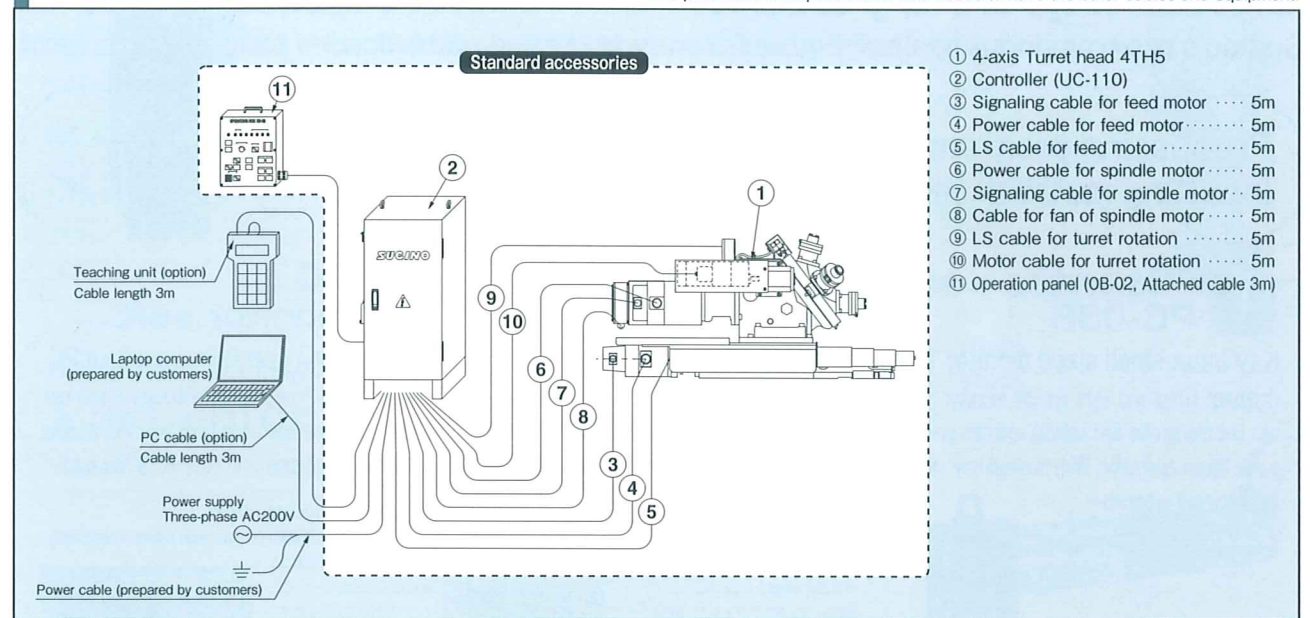

Operation panel and Controller

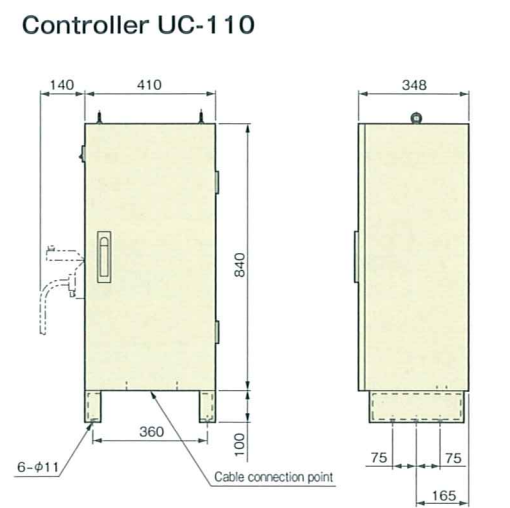
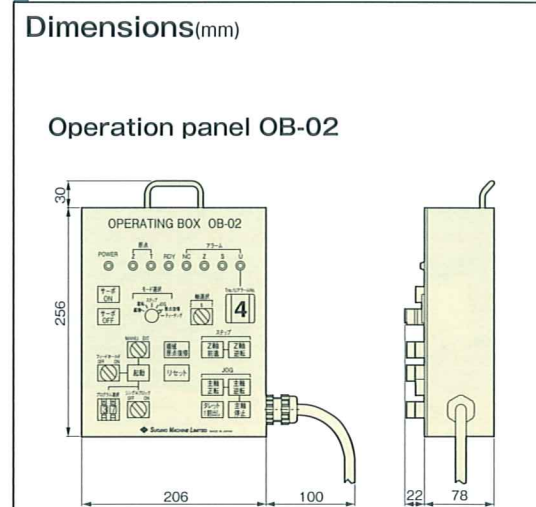

Specification of Controller

Model No.	NCBOY-200		
Controlled axes	1 axis (Z axis) + S axis		
*1 NC Program	Input commands	Least input increment : 0.001mm	
		Least command increment : 0.001mm	
		Max. programmable dimension : 999999999.999mm Decimal point input.	
	G function (Any other G code can not accept except right G code)	Cutting feed rate : F mm/min direct command	
		G00 Positioning	G31 Skip function
		G01 Liner interpolation	G53 Command in machine coordinate system
		G04 Dwell	G90 Absolute command
		G09 Positioning check	G91 Incremental command
		G11 Time-fixed feeding	G92 Coordinate system setting
		G28 Automatic return to reference point	
		M function (For external output)	M50~M57 : Codes for customer.
		Special function	RTAPX Tapping.
		S function	Command spindle speed, rotation start and stop.
		T function	Command assignment turret No. and turret index start.
		Various calculate function	○ (Available in NC program.)
Confirm NC status, Setting or reference I/O parameter	○ (Available only in NC program.)		
Use of register	○ (Available for coordinate address.)		
Macro command	x		
Canned cycle	x		
Tool life management	x		
Operation panel	Using in case of manual operation.		
Description for components	*1 Teaching unit	-Inputting, reference and changing the NC program. -Reference and Changing the parameter of NC program and amplifier. -Monitoring the operating conditions of NC program and amplifier.	
	PC software		
	*2 Output signal	Machine zero return. Servo motor ON. Cycle run. Program end. Alarm	
External I/O signal	*3 Input signal	M50~M57 : Codes for customer.	
		Automatic operation start.	
		External emergency stop.	
		Reset	
		Program No.1 (Assign program No.)	
		Program No.2 (Assign program No.)	
		Program No.4 (Assign program No.)	
		Program No.8 (Assign program No.)	
		Program No.10 (Assign program No.)	
		Program No.20 (Assign program No.)	
Program No.40 (Assign program No.)			
Program No.80 (Assign program No.)			
M code FIN.			

*1 NC programming is recommended to use together with PC software.
 *2 Voltage : DC24V, current : less or equal 40mA.

Max. Drilling size (mm)

Aluminium
φ20

Steel
φ13

Max. Tapping size (mm)

Aluminium
M16

Steel
M12

Selfeeder Varimec

Selfeeder Mechatric

CNC Turret Head

Data input system /
other attachments

Data input system

Sugino's program input system; high-efficiency and easy-operation.

Processing program inputting method (Option)

For controller UC-81A, 82 and 83A, Sugino has 3 options for inputting data, confirming the condition, single unit manual operating, and seeing alarms.



1 Programming console PC-03B

Key input small sized monitor type
Compact sized and light weight monitor which can set the stroke and spindle rotation speed in a one touch operation. With minimal key strokes quickly input programs.

Attached cable (3m)



2 Touch panel TP-01

Easy operation by touch panel
5.7inch color type liquid crystal pouch panel. Beginners are also able to produce and operate CNC programs very easily.

Indicate language:
→Japanese, English, Chinese and Korean
Attached cable (3m)
Back up memory (Option):
→Compact flash card (32MB)
→Compact flash reader writer



3 PC monitor soft

Programming operation from your PC
Use exclusive type monitor software which can do programming operation from your PC. Special cable for connecting with your PC is required.

Working environment
→OS Windows 95/98/XP (The mode setting is necessary)
Communication interface
→RS232C-port



Multi drop connection

By connecting multiple controllers with multi drop cable, programming can be achieved without pulling out cables. (Maximum 10 controllers are connected.)

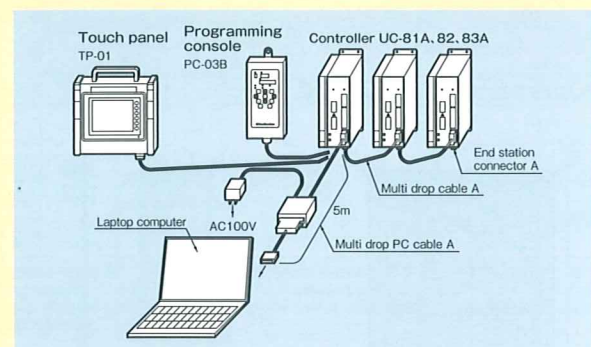

Process patterns

14 process patterns included in the UC-8* Controller. Simply choose suitable pattern for your processing specification.

Pattern No.	Function
01	Drilling
02	High-speed deep hole drilling (Step feed drilling)
03	Deep hole drilling (Step feed drilling)
04	Quill pipe drilling (Skip feed drilling)
05	Drilling Counterboring
06	Drilling (with inching feed)
07	High-speed deep hole drilling (with inching feed)
08	Deep hole drilling (with inching feed)
09	Quill pipe drilling (with inching feed)
10	Drilling Counterboring (with inching feed)
11	Back chamfering
12	Quill pipe multi-step drilling (with inching feed)
13	2-step front/rear chamfering
15	Non-step deep hole drilling

Example of process patterns

No.03 Deep hole drilling (Step feed drilling)

Applied for Deep hole drilling, generally referred to as step drilling. Cutting oil delivered to edge of drill bit because the drill bit is pulled out of workpiece in each step motion.

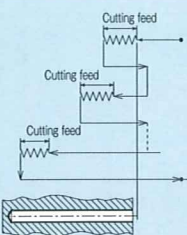

No.05 Drilling Counterboring

Applied to perform counterboring after drilling. Also applied to reduce burrs on the rear surface at through hole drilling.

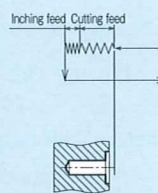

No.06 Drilling (with inching feed)

Applied to reduce burrs on the both front and rear surface.

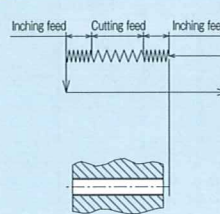

No.09 Quill pipe drilling (with inching feed)

Capable of inching feed for process pattern No.4 when drill biting and through-hole are performed. Helps to reduce burrs.

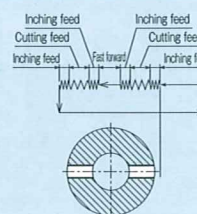

Other attachments

Additional Sugino products which can achieve high-efficient operations besides Selffeeder servo series.

NC automatic drilling machine Standrill NC

All that is needed for operation on the same day is a connection with the main power supply. This is an NC automatic drilling machine available not only for drilling but also tapping. An optional touch panel allows easy operation of NC programs even if the user is a beginner.



High rigidity spindle motor Varimotor

The same high-rigidity and high-power DC brushless motor and precise angular bearing as the Selffeeder Varimec are utilized. It is compact sized spindle unit and capable of doing heavy cut processing.

Application

1. Install into spindle unit for drilling and end-milling operation
2. Install into robot for de-burring operation.
3. Install into special purpose machine for various cutting operations.



Specification Chart

Specs.	Spindle speed (no load)		Chuck type (Collet chuck)	Chucking capacity	Max. Drilling size			Spindle motor (Max. output)	Weight
	50Hz	60Hz			AL* (ADC)	FC* (FC200)	ST* (S45C)		
Model	min ⁻¹		—	mm	mm	mm	mm	kW	kg
SSV2-7200CM	2,000~20,000		ER11MS	0.5~7.0	5	4	3.5	0.9	4
SSV2-1039CM	390~3,900		ER16	0.5~10.0	8.5	7.5	6.5		
SSV3-7100CM	1,000~10,000		ER11	0.5~7.0	6.5	5	4	0.4	12
SSV3-1626CM	265~2,650		ER20	0.5~13.0					
SSV3-1626CM			ER25	0.5~16.0					
SSV4-2070CM	1,000~7,000		ER32	1.0~20.0	9	8	7	1.0	24
SSV4-2017CM	250~1,750				16	15	13		
SSV5-2055CM	800~5,500		ER32	1.0~20.0	14.5	11.5	9.5	1.6	43
SSV5-2610CM	250~1,010		ER40	2.0~26.0	25	20.5	18		

Notes 1. To select your model, refer to the workpiece configurations, material, cutting properties, diameter of the hole, and rotation speed.(cutting speed)
2. The drilling capacity shown above is for a depth equivalent to the drill diameter times two.
3. The power voltage is a 3-phase 200V AC±10%, 50/60Hz.
4. For cooling the motor in inside, please input clean dry air into air-inlet.
5. Please take care for not closing the air-outlet for motor cooling by clamp fixture etc. Also please set the air-outlet certainly becomes downward.
6. The leading direction of cable is different from the type of Varimotor. If you need more detailed information, please ask your nearest sales offices.
7. AL*...Aluminium, FC*...Cast Iron, ST*...Steel

Dimensions(mm)

Fig.1 (SSV2CM)

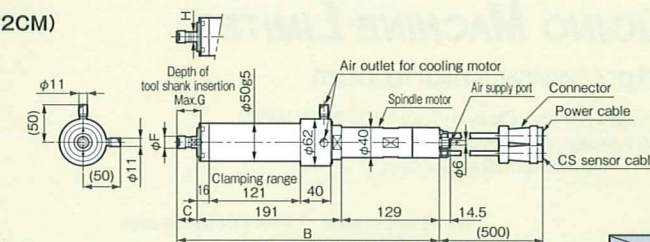
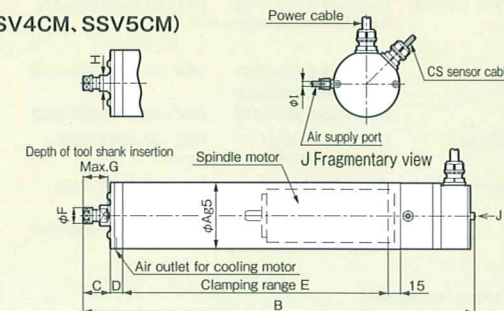

Fig.2 (SSV3CM, SSV4CM, SSV5CM)



Model	Symbol	Fig. No.	A	B	C	D	E	F	G	H	I
SSV2-7200CM		1	-	347	27	-	-	16	31	13	-
SSV2-1039CM		1	-	361	41	-	-	28	35	19	-
SSV3-7100CM		1	80	473	42	15	320	34	60	27	6
SSV3-1626CM		2			46			42		32	
SSV4-2070CM		2	100	659.5	58		454.5	50	58	36	8
SSV4-2017CM		2									
SSV5-2055CM		2	120	807.5	71	19	519	63	60	46	
SSV5-2610CM		2									

Note: The C, F and G dimension in this drawing will change with the spindle specification which shown in the above capacity table.