



selffeederTM electric

selfeeder™ electric

Many Outstanding Features!

- Maximum .0004" T.I.R. (0.010mm) spindle runout.
- $\pm .0008"$ ($\pm 0.02\text{mm}$) depth repeatability using mechanical front limit stop or optional Micro-stopper.
- 1/4 through 7.5 horsepower (.20 - 5.5kw).
- Wide selection of spindle speeds.
- Quick change spindle speeds.
- Infinitely variable feed rates.
- Patented no-drift spindle design. Spindle stays at home position when power is off.
- Hardened center bar and ram assembly for unsurpassed rigidity, spindle accuracy, and extra long service life.
- Internal guide bar maintains precision alignment through the entire drilling stroke.
- Self lubricating guide bar bushings for smooth, accurate drilling motions and long, trouble free life.
- See-through safety covers for added operator protection.
- Advanced spindle sealing keeps contaminants out.
- Heavy-duty construction throughout for utmost rigidity.
- Long stroke units available for special applications.
- Larger standard spindle motors, 3 phase, 230/460V (575 and 115V available).
- 29 point inspection and run-in test for each and every Electric Selfeeder.

Typical Application

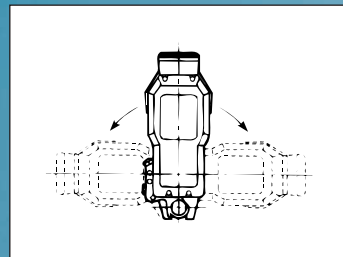

Unique 3-way spindle motor positioning for mounting flexibility.

Table of Contents

ES

ES2-U	3
ES3C-LU	5
ES3P-LU	7
ES4P-LU	9
ES5-U	11
ES6-U	13
ES7-U	15
Collet Spindles	17
ASA Spindles	18
Level Clamps	19
Flex Stands	20
Hydro Speed Regulators	21
Air Diagrams/Electrical Schematics ..	23
MCB-1 Peck Feed Controller	25
Operating Signal Kits	27
Drill Chucks, Collets, Micro Stopper ..	28
Double Angle Collets	29

selfeeder™ electric

ES2

Carbon Steel 7/32"

Aluminium 5/16"

Smallest and lightest Selfeeder drills small-diameter holes at 12,000 r.p.m.

ES2
Selfeeder electric

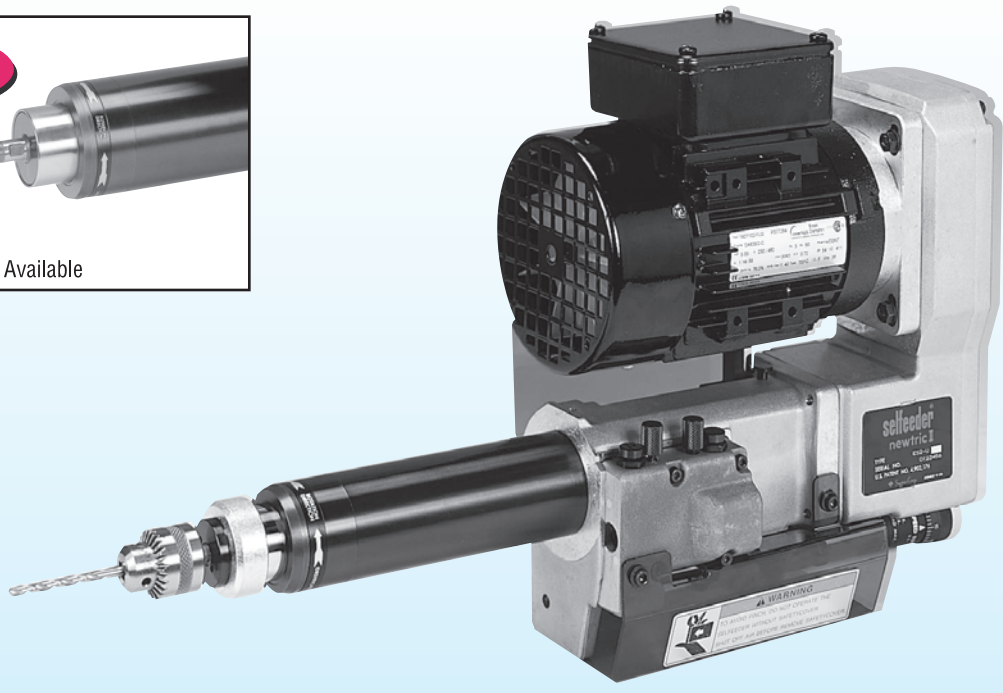
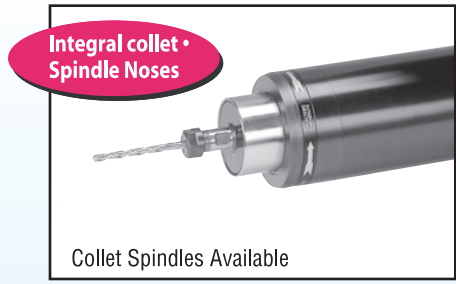

ES2-U Specification Chart

Operating air pressure: 85 PSI

Specifications Model No.	Spindle RPM (no load) 60Hz min ⁻¹	Drill Chuck Capacity In (mm)	Spindle Taper	Typical Drill Size						Theoretical Spindle Torque Ft. Lbs.	Stroke		Motor		Thrust Lbs	Air Consumption Ft ³ /stroke	Weight Lbs
				Aluminum		Cast Iron		Mild Steel			Ram	Optional Feed Regulator	Output	No. of Pole			
				In	mm	In	mm	In	mm		In (mm)	In (mm)	Hp	P			
ES2-2-3100U	12,000	1/8 (3)	JT1	3/32	2.5	3/64	1	3/64	1	0.14	3.15 (80) Standard Stroke 'U'	Spring RB-2430 1.18 (30) RB-2460 2.36 (60) Air (Peck) R-2442A 1.57(42) R-2462A 2.36(62) R-2482A 3.15(82)	1/3	2	132	0.7	30.8
ES2-2-3085U	10,000	(Keyless Drill Chuck)		1/8	3	3/64	1	3/64	1	0.17							
ES2-2-3060U	7,200			5/32	4	1/16	1.5	1/16	1.5	0.24							
ES2-2-6045U	5,400	1/4 (6.5)		7/32	5.5	5/64	2.5	5/64	2	0.32							
ES2-2-6030U	3,600			17/64	6.5	1/8	3	3/32	2.5	0.48							
ES2-2-6020U	2,400			19/64	7.5	11/64	4.5	11/64	4.5	0.72							
ES2-2-6014U	1,700			5/16	8	1/4	6.5	7/32	5.5	1.02							

Note:
 1. Model selection from the chart above based on workpiece specifications, material hardness, diameter of hole and cutting speed.
 2. The drilling capacity shown above is for a depth equivalent of the drill diameter times two based on HSS tooling. For capacity beyond one spindle, see Multi-Spindle Head Catalog.
 3. The maximum weight of any attachment for downward drilling is 5.5 lbs.
 4. Spindle and body air purge is available on all Electric units.

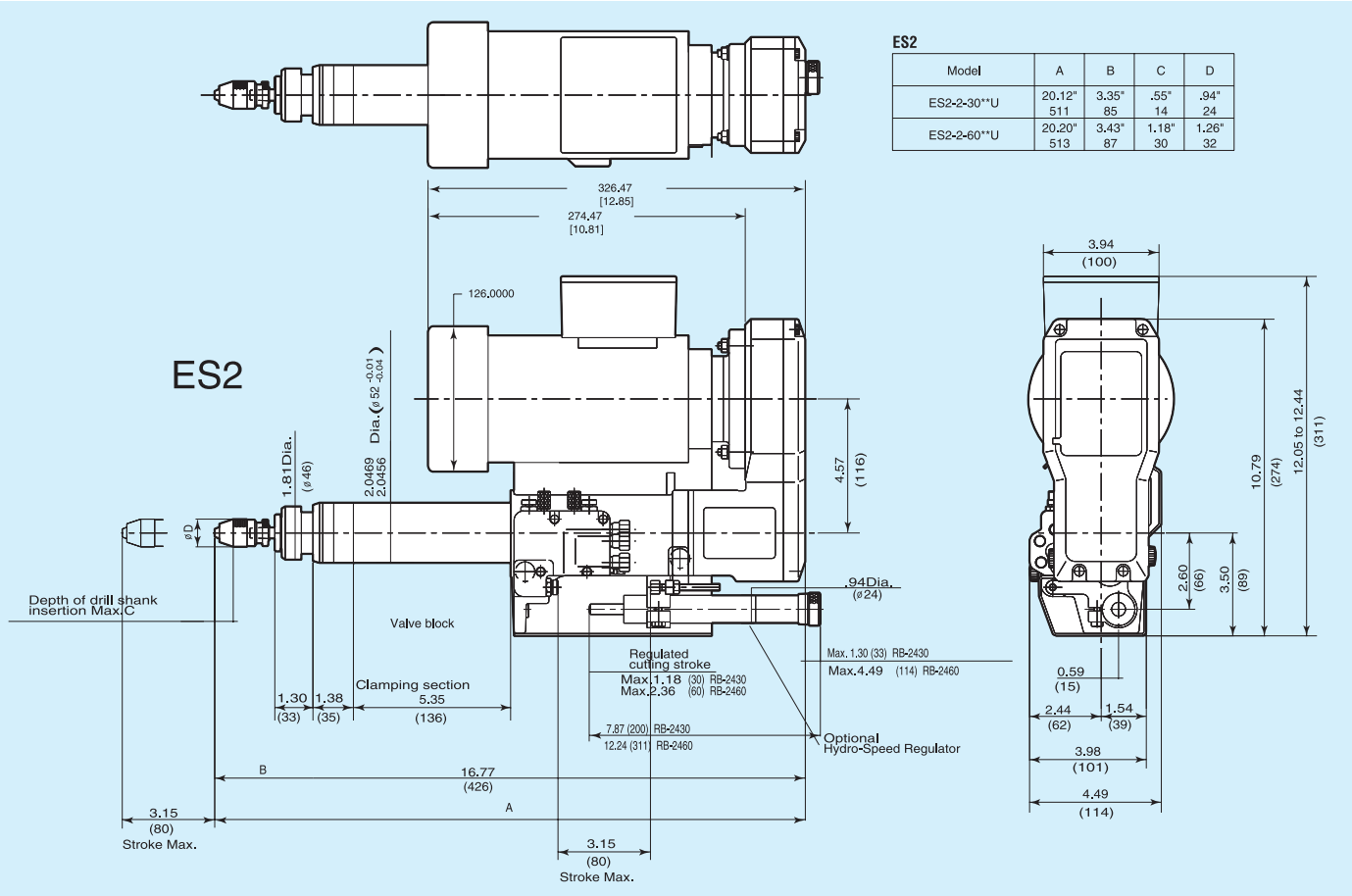

How To Order:

ES2-U SERIES

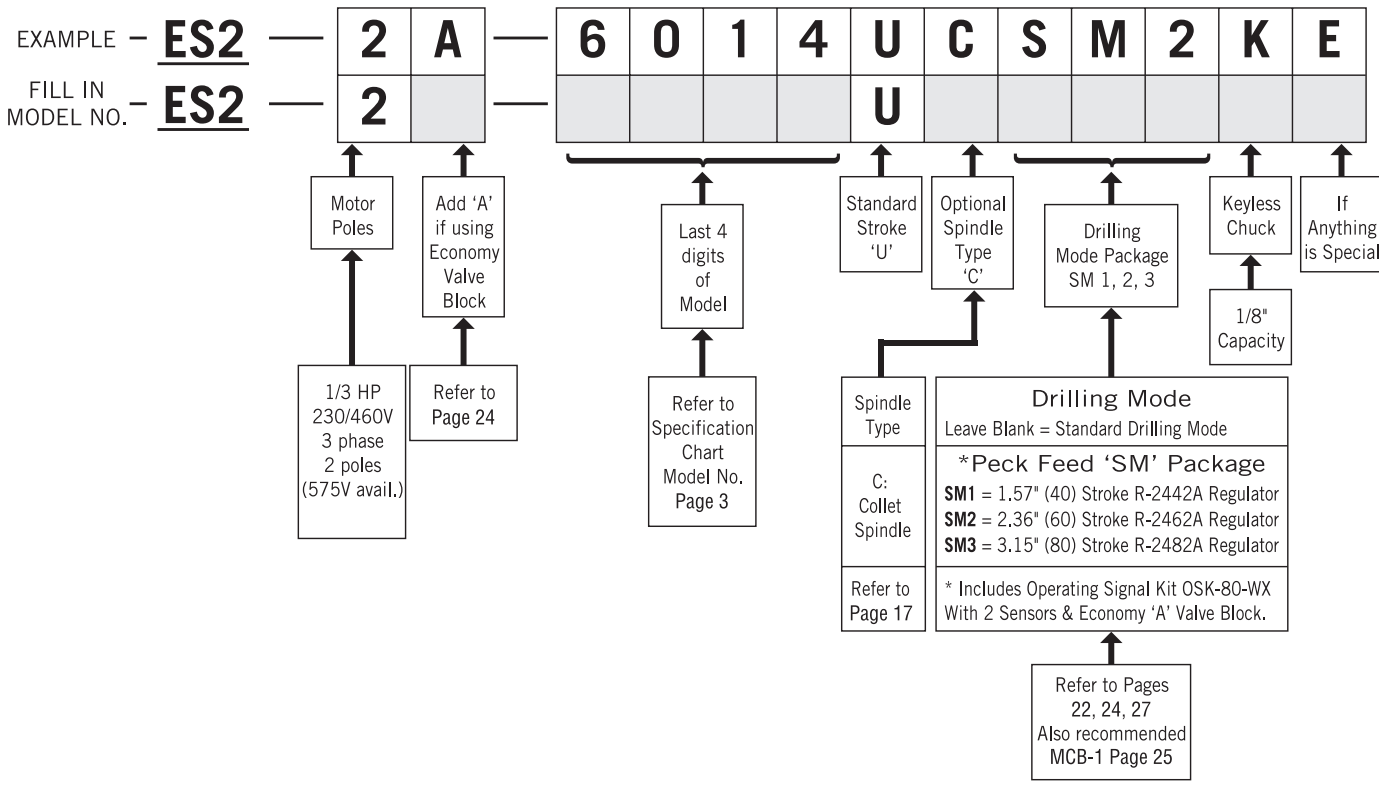

selfeeder™ electric

ES3C	Carbon Steel	5/16"
	Aluminium	7/16"

*Slim, in line body configuration
ideally suited for tight spaces.*

ES3C

Selfeeder electric

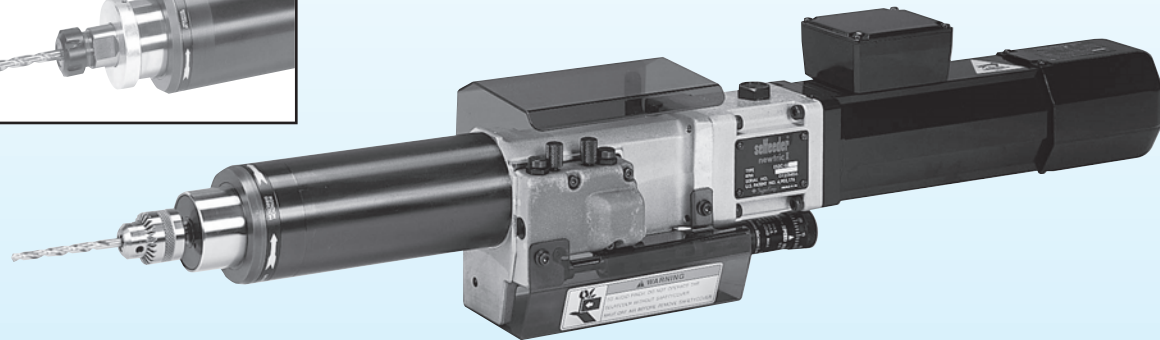
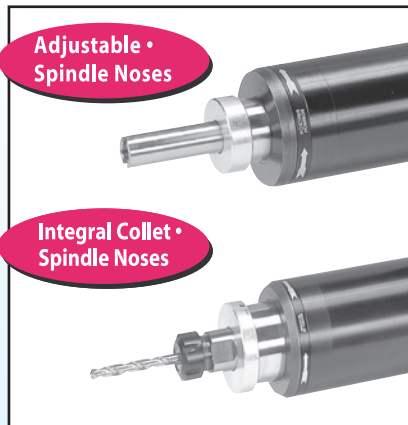

ES3C-LU Specification Chart

Operating air pressure: 85 PSI

Specifications Model No.	Spindle RPM (no load) 60Hz min ⁻¹	Drill Chuck Capacity In (mm)	Spindle Taper	Typical Drill Size						Theoretical Spindle Torque Ft. Lbs.	Stroke		Motor		Thrust Lbs	Air Consumption Ft ³ /stroke	Weight Lbs
				Aluminum		Cast Iron		Mild Steel			Max	Optional Feed Regulator	Output	No. of Pole			
				In	mm	In	mm	In	mm		In (mm)	In (mm)	Hp	P			
ES3C-2-6030LU	3,600	1/4 (6.5)	JT1	13/64	5	3/32	2.5	5/64	2	0.36	3.15 (80) Standard Stroke 'LU'	Spring RB-2430 1.18(30) RB-2460 2.36(60) Air (Peck) RB-2442 1.57(42) R-2462A 2.36(62) R-2482A 3.15(82)	1/4	2	264	.105- .140	35.2
ES3C-2-5022LU	2,600			15/64	6	11/64	4.5	5/32	4	0.51							
ES3C-2-1314LU	1,700	1/2 (13)	JT33	19/64	7.5	15/64	6	13/64	5	0.77							
ES3C-2-1309LU	1,100			5/16	8	9/32	7	15/64	6	1.19							
ES3C-2-1305LU	650			7/16	11	11/32	8.5	5/16	8	2.02							

Note:

1. Model selection from the chart above based on workpiece specifications, material hardness, diameter of hole and cutting speed.
2. The drilling capacity shown above is for a depth equivalent of the drill diameter times two based on HSS tooling. For capacity beyond one spindle, see Multi-Spindle Head Catalog.
3. The maximum weight of any attachment for downward drilling is 26.4 lbs.
4. Spindle and body air purge is available on all Electric units.

ES3C-LU Dimensions: In. (mm)

Model	A	B	C	D	T
ES3C-2-60**LU	32.16 (817)	3.19 (81)	1.26 (32)	1.18 (30)	JT1
ES3C-2-13**LU	33.58 (853)	4.25 (108)	1.38 (35)	1.97 (50)	JT33

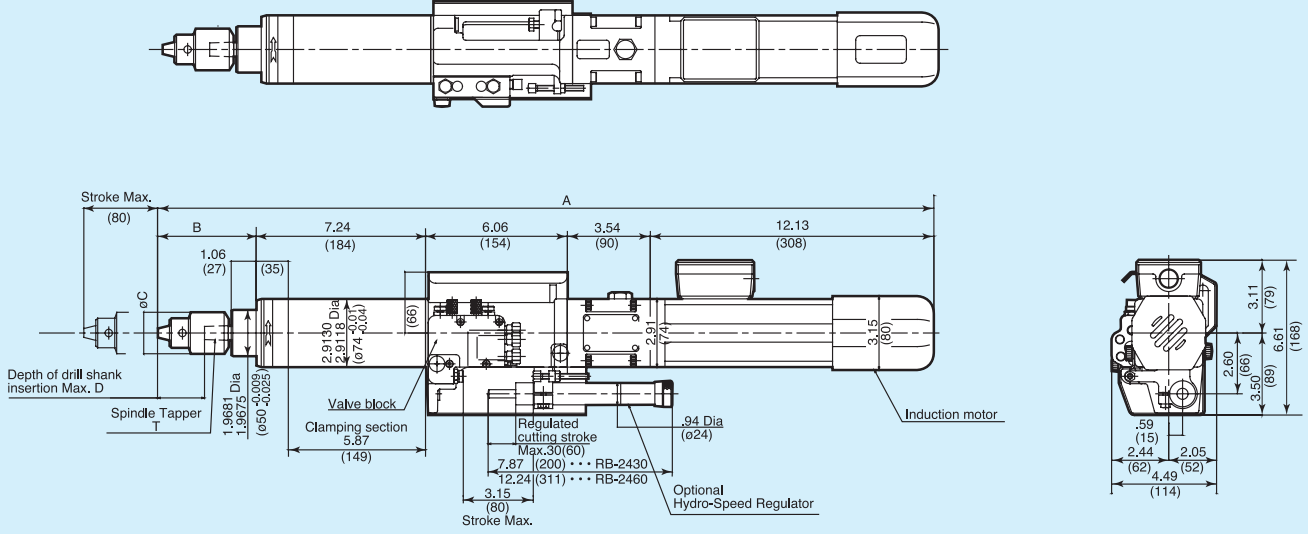

How To Order:

ES3C-LU SERIES

EXAMPLE — **ES3C** — **2 A** — **6 0 2 2 L U S 5 S M 2 K E**

FILL IN MODEL NO. — **ES3C** — **2** — **LU** — **SM** — **2** — **K E**

- Motor Poles:** 1/4 HP 230/460V 3 phase 2 poles (575V avail.)
- Add 'A' if using Economy Valve Block:** Refer to Page 24
- Last 4 digits of Model:** Refer to Specification Chart Model No. Page 5
- LU Standard Stroke 3.15"**
- Optional Spindle Type 'C':** 5 if 5/8-16, 3 if 3/4-12
- Drilling Mode Package SM 1, 2, or 3:**
 - *Peck Feed 'SM' Package**
 - SM1 = 1.57" (40) Stroke R-2442A Regulator**
 - SM2 = 2.36" (60) Stroke R-2462A Regulator**
 - SM3 = 3.15" (80) Stroke R-2482A Regulator**
 - * Includes Operating Signal Kit OSK-80-WX With 2 Sensors & Economy 'A' Valve Block.**
- Keyless Chuck:** 1/8" Capacity
- If Anything is Special:**

Spindle Type: C: Collet Spindle, S: ASA Spindle (Automotive Style Quick Change). Refer to Pages 17, 18

Drilling Mode: Leave Blank = Standard Drilling Mode. Refer to Pages 22, 24, 27 (Also recommended MCB-1 Page 25)

selfeeder™ electric

ES3P

Carbon Steel 23/64"

Aluminium 17/32"

1/2 - 3/4 HP motors increase drilling power,
ideal for high speed drilling

**DC MOTOR
AVAILABLE**

ES3P

Selfeeder electric

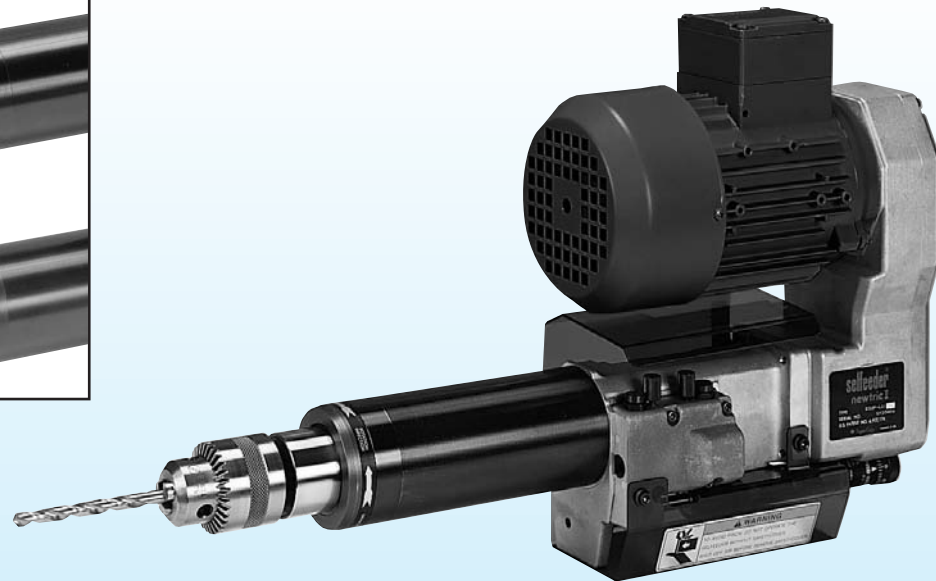
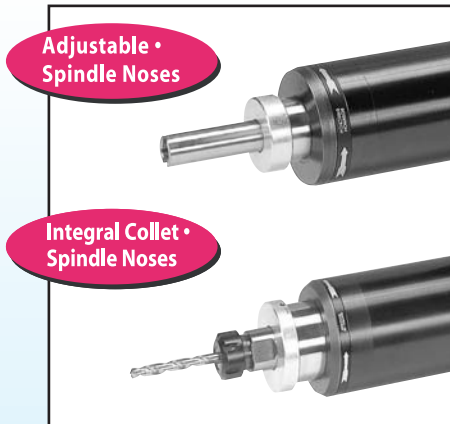

ES3P-LU Specification Chart

Operating air pressure: 85 PSI

Specifications Model No.	Spindle RPM (no load) 60Hz min-1	Drill Chuck Capacity In. (mm)	Spindle Taper	Typical Drill Size						Theoretical Spindle Torque Ft. Lbs.	Stroke		Motor		Thrust Lbs	Air Consumption Ft ³ /stroke Lbs	Weight Lbs
				Aluminum		Cast Iron		Mild Steel			Max.	Optional Feed Regulator	Output	No. of Pole			
				In	mm	In	mm	In	mm		In. (mm)	In (mm)	Hp	P			
ES3P-2-3075L(LL)U	9,000	1/8 (3)	JT1	1/8	3	1/16	1.5	1/16	1.5	.44	3.15 (80) Standard Stroke 'LU'	Spring RB-2430 1.18(30) RB-2460 2.36(60)	3/4	2	264	.105~ .210	44 'LU'
ES3P-2-3060L(LL)U	7,200	Keyless		5/32	4	1/16	1.5	1/16	1.5	.55							
ES3P-2-6054L(LL)U	6,500	1/4 (6.5)		13/64	5	1/16	1.5	1/16	1.5	.61							
ES3P-2-6049L(LL)U	5,900			13/64	5	5/64	2	5/64	2	.66							
ES3P-2-6043L(LL)U	5,200			7/32	5.5	5/64	2	5/64	2	.76							
ES3P-2-6034L(LL)U	4,100			15/64	6	1/8	3	1/8	3	.96							
ES3P-2-1330L(LL)U	3,600	1/2 (13)	JT33	5/16	8	1/8	3	1/8	3	1.09	5.91 (150) Long Stroke 'LLU'	Air (Peck) R-2442A 1.57(42) R-2462A 2.36(60) R-2482A 3.15(82)	1/2	4	264	.105~ .210	46 'LU'
ES3P-2-1326L(LL)U	3,200			11/32	8.5	9/64	3.5	9/64	3.5	1.23							
ES3P-2-1321L(LL)U	2,500			23/64	9	11/64	4.5	11/64	4.5	1.58							
ES3P-2-1318L(LL)U	2,200			3/8	9.5	13/64	5	13/64	5	1.79							
ES3P-2-1315L(LL)U	1,800			27/64	10.5	15/64	6	15/64	6	2.19							
ES3P-4-1338L(LL)U	4,500			1/4	6.5	3/32	2.5	3/32	2.5	0.58							
ES3P-4-1330L(LL)U	3,600			19/64	7.5	1/8	3	1/8	3	0.73							
ES3P-4-1327L(LL)U	3,200			19/64	7.5	9/64	3.5	9/64	3.5	0.82							
ES3P-4-1325L(LL)U	2,900			19/64	7.5	9/64	3.5	9/64	3.5	0.91							
ES3P-4-1322L(LL)U	2,600			5/16	8	5/32	4	5/32	4	1.01							
ES3P-4-1317L(LL)U	2,000			11/32	8.5	7/32	5.5	7/32	5.5	1.31							
ES3P-4-1315L(LL)U	1,800			23/64	9	15/64	6	15/64	6	1.46							
ES3P-4-1313L(LL)U	1,600			3/8	9.5	9/32	7	9/32	7	1.64							
ES3P-4-1310L(LL)U	1,200			27/64	10.5	23/64	9	19/64	7.5	2.19							
ES3P-4-1309L(LL)U	1,100			7/16	11	23/64	9	5/16	8	2.39							
ES3P-4-1307L(LL)U	900			1/2	12.5	25/64	10	11/32	8.5	2.92							

Note:

1. Models with (LL) are for the long stroke units.
2. Model selection from the chart above based on workpiece specifications, material hardness, diameter of hole and cutting speed.
3. The drilling capacity shown above is for a depth equivalent to the drill diameter times two based on HSS tooling. For capacity beyond one spindle, see Multi-Spindle Head Catalog.
4. The maximum weight of any attachment for downward drilling is 26.4 lbs.
5. Spindle and body air purge is available on all Electric units.

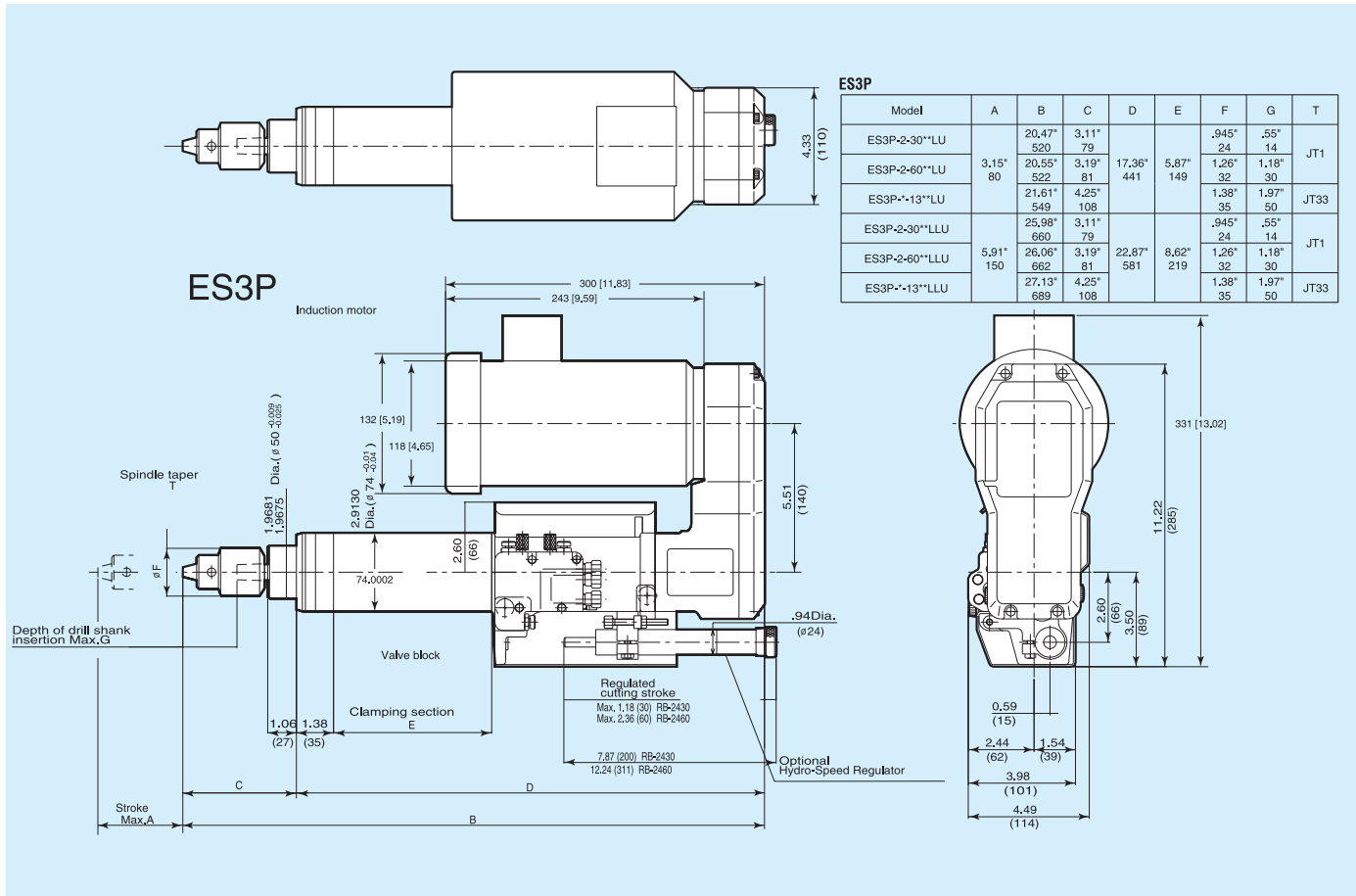

How To Order:

ES3P-LU (LLU) SERIES

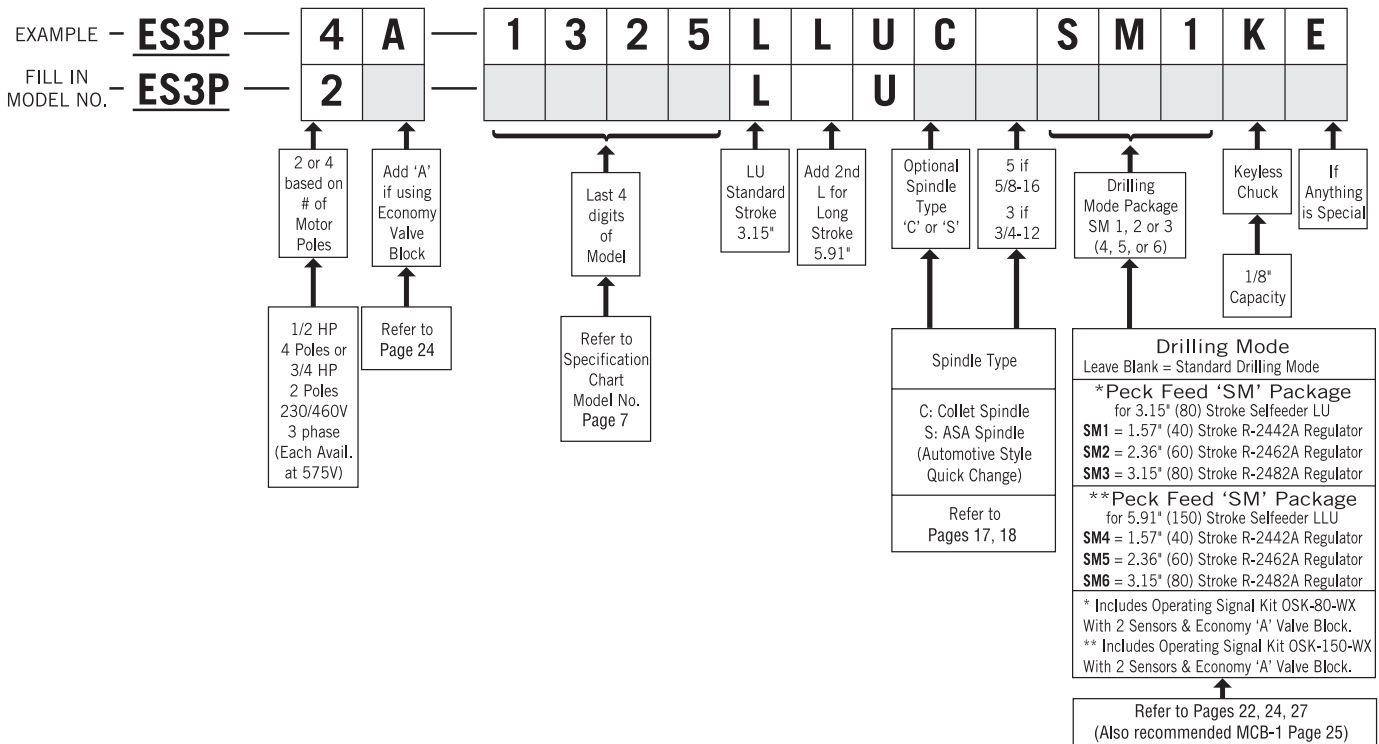

selfeeder™ electric

ES4P

Carbon Steel 15/32"

Aluminium 5/8"

Enhanced drilling power ideal for high speed drilling.

ES4P

Selfeeder electric

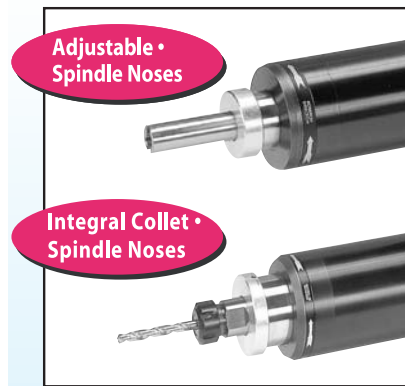

ES4P Specification Chart

Operating air pressure: 85 PSI

Specifications Model No.	Spindle RPM (no load) 60Hz min-1	Drill Chuck Capacity In. (mm)	Spindle Taper	Typical Drill Size						Theoretical Spindle Torque Ft. Lbs.	Stroke		Motor		Thrust Lbs	Air Consumption Ft ³ /stroke	Weight Lbs	
				Aluminum		Cast Iron		Mild Steel			Max.	Optional Feed Regulator	Output	No. of Pole				
				In	mm	In	mm	In	mm		In. (mm)	In (mm)	Hp	P				
ES4P-2-6061 (L)U	7,300	1/4	JT1	13/64	5	1/16	1.5	1/16	1.5	.72	3.94 (100) Standard Stroke 'U'	Spring RB-3140 1.57(40) RB-3160 2.36(60)	1.5	2	400	.211~ .353	'U' 69 'LU' 74	
ES4P-2-6045 (L)U	5,400	(6.5)		7/32	5.5	5/64	2	5/64	2	.97								
ES4P-2-1330 (L)U	3,600			9/32	7	9/64	3.5	1/8	3	1.46								
ES4P-2-1320 (L)U	2,400			23/64	8	13/64	5	11/64	4.5	2.19								
ES4P-2-1314 (L)U	1,700			25/64	10	15/64	6	15/64	6	3.09								
ES4P-4-1311 (L)U	1,400	1/2 (13)		JT33	7/16	11	5/16	8	9/32	7	2.81	7.87 (200) Long Stroke 'LU'	Air (Peck) R-3182A 3.15(80) R-31132A 5.19(130)	1				4
ES4P-4-1308 (L)U	1,000				15/32	12	23/64	9	5/16	8	3.94							
ES4P-4-1306 (L)U	700				35/64	14	7/16	11	23/64	9	5.63							
ES4P-4-1304 (L)U	550				37/64	14.5	1/2	12.5	7/16	11	7.16							
ES4P-4-1303 (L)U	380				19/32	15	33/64	13	7/16	11	10.37							
ES4P-4-1302 (L)U	250		5/8		16	17/64	13.5	15/32	12	15.75						'U' 77 'LU' 88		

Note:
 1. Models with (LU) are for the long stroke units.
 2. Model selection from the chart above based on workpiece specifications, material hardness, diameter of hole and cutting speed.
 3. The drilling capacity shown above is for a depth equivalent to the drill diameter times two based on HSS tooling.
 4. The maximum weight of any attachment for downward drilling is 33 lbs.
 5. Spindle and body air purge is available on all Electric units.

selfeeder™ electric

ES5

Carbon Steel 33/64"

Aluminium 43/64"

Round-body type Selfeeder, with higher torque and greater thrust.
Compact, special-purpose machines can be designed.

ES5
Selfeeder electric

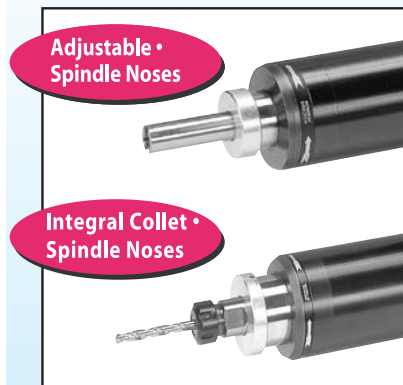

DC MOTOR AVAILABLE



ES5-U Specification Chart

Operating air pressure: 85 PSI

Specifications Model No.	Spindle RPM (no load) 60Hz min ⁻¹	Drill Chuck Capacity In (mm)	Spindle Taper	Typical Drill Size						Theoretical Spindle Torque Ft. Lbs.	Stroke		Motor		Thrust Lbs	Air Consumption Ft ³ /stroke	Weight Lbs																									
				Aluminum		Cast Iron		Mild Steel			Max.	Optional Feed Regulator	Output	No. of Pole																												
				In	mm	In	mm	In	mm		In. (mm)	In (mm)	Hp	P																												
ES5-2-6061U	7,300	1/4 (6.5)	JT1	5/32	4	1/16	1.5	1/16	1.5	1.08	3.94 (100) Standard Stroke 'U'	Spring RB-3140 1.57 (40) RB-3160 2.36 (60) Air (Peck) R-3182A 3.15 (80) R-31132A 6.19 (130)	1	4	539	.245~ .420	81 'U'																									
ES5-2-6052U	6,200			11/64	5	1/16	1.5	1/16	1.5	1.27																																
ES5-2-6045U	5,400			7/32	5.5	5/64	2	5/64	2	1.46																																
ES5-2-1338U	4,600	1/2 (13)	JT33	1/4	6.5	3/32	2.5	3/32	2.5	1.71								3.94 (100) Standard Stroke 'U'	Spring RB-3140 1.57 (40) RB-3160 2.36 (60) Air (Peck) R-3182A 3.15 (80) R-31132A 6.19 (130)	1	4	539	.245~ .420	81 'U'																		
ES5-2-1330U	3,600			11/32	8.5	1/8	3	1/8	3	2.19																																
ES5-2-1323U	2,800			7/16	11	5/32	4	5/32	4	2.81																																
ES5-2-1320U	2,400			15/32	12	11/64	4.5	11/64	4.5	3.28																																
ES5-2-1317U	2,100			33/64	13	13/64	5	13/64	5	3.75																																
ES5-2-1314U	1,700			35/64	14	1/4	6.5	1/4	6.5	4.63																																
ES5-2-1312U	1,400			19/32	15	5/16	8	5/16	8	5.63																																
ES5-4-1330U	3,600			1/2 (13)	JT33	11/32	8.5	1/8	3	1/8															3	1.46	3.94 (100) Standard Stroke 'U'	Spring RB-3140 1.57 (40) RB-3160 2.36 (60) Air (Peck) R-3182A 3.15 (80) R-31132A 6.19 (130)	1	4	539	.245~ .420	81 'U'									
ES5-4-1326U	3,100					3/8	9.5	9/64	3.5	9/64															3.5	1.69																
ES5-4-1322U	2,700					27/64	10.5	5/32	4	5/32															4	1.95																
ES5-4-1319U	2,300					7/16	11	11/64	4.5	11/64															4.5	2.28																
ES5-4-1315U	1,800					1/2	12.5	15/64	6	15/64															6	2.92																
ES5-4-1311U	1,400					33/64	13	5/16	8	5/16															8	3.75																
ES5-4-1310U	1,200					35/64	14	23/64	9	23/64															9	4.38																
ES5-4-1308U	1,000					19/32	15	7/16	11	7/16															11	5.25																
ES5-4-1307U	850					5/8	16	33/64	13	29/64															11.5	6.18																
ES5-4-1306U	700					43/64	17	35/64	14	29/64															11.5	7.50																
ES5-6-1320U	2,400					1/2 (13)	JT33	3/8	9.5	11/64															4.5	11/64								4.5	1.64	3.94 (100) Standard Stroke 'U'	Spring RB-3140 1.57 (40) RB-3160 2.36 (60) Air (Peck) R-3182A 3.15 (80) R-31132A 6.19 (130)	3/4	6	539	.245~ .420	81 'U'
ES5-6-1317U	2,100							25/64	10	13/64															5	13/64								5	1.88							
ES5-6-1315U	1,800							27/64	10.5	15/64															6	15/64								6	2.19							
ES5-6-1313U	1,500							29/64	11.5	9/32															7	9/32								7	2.63							
ES5-6-1310U	1,200	33/64	13					23/64	9	23/64								9	3.28																							
ES5-6-1308U	930	35/64	14					15/32	12	25/64								10	4.24																							
ES5-6-1307U	800	19/32	15					33/64	13	27/64								10.5	4.92																							
ES5-6-1306U	700	19/32	15					33/64	13	7/16								11	5.63																							
ES5-6-1305U	590	5/8	16					35/64	14	15/32								12	6.68																							
ES5-6-1304U	480	43/64	17					19/32	15	33/64								13	8.21																							

Note:
1. Model selection from the chart above based on material hardness, diameter of hole and cutting speed (based on HSS tooling, dia. X 2).
2. The maximum weight of any attachment for downward drilling is 55 lbs.
3. Spindle and body air purge is available on all Electric units.
4. Refer to Multi-Spindle Head Catalog for capacities beyond one spindle.

selfeeder™ electric

ES6

Carbon Steel 3/4"

Aluminium 61/64"

DC MOTOR AVAILABLE

Rigid unit with keyed base

Motor options provide substantial working torque

ES6
Selfeeder electric

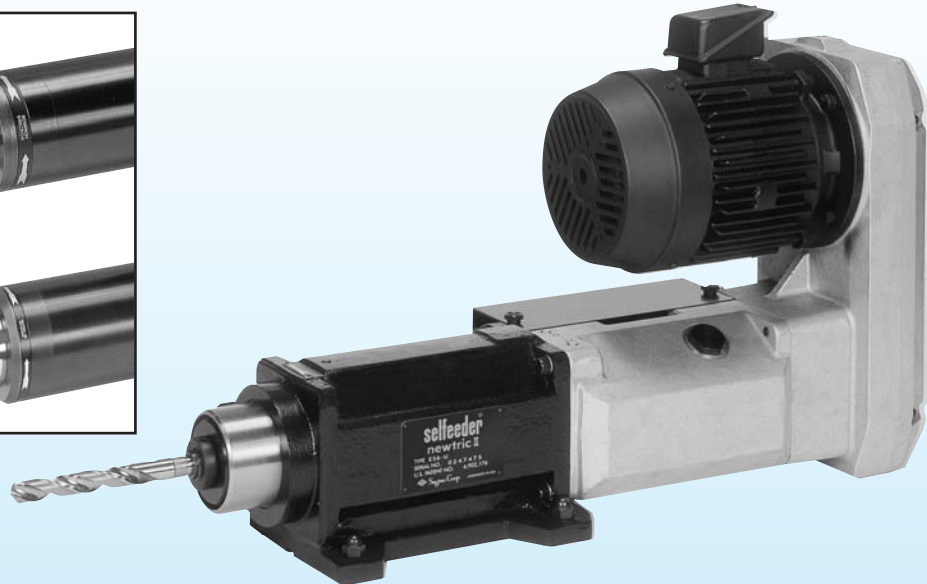
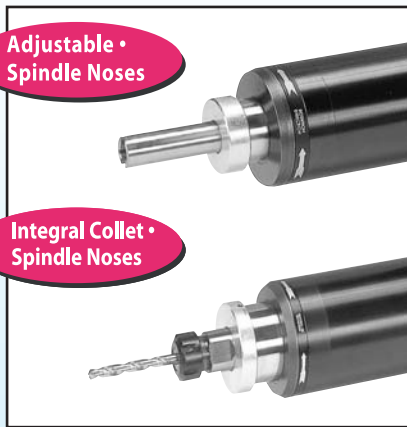

ES6-U Specification Chart

Operating air pressure: 85 PSI

Specifications Model No.	Spindle RPM (no load) 60Hz min ⁻¹	Spindle Type	Typical Drill Size						Theoretical Spindle Torque Ft. Lbs.	Stroke		Motor		Thrust Lbs	Air Consumption Ft ³ /stroke	Weight Lbs
			Aluminum		Cast Iron		Mild Steel			Max.	Optional Feed Regulator	Output	No. of Poles			
			In	mm	In	mm	In	mm		In (mm)	In (mm)	Hp	P			
ES6-2-2435U	4,200	MT2	23/64	9	1/8	3	1/8	3	3.75	5.91 (150) Standard Stroke 'U'	Spring RB-3860 2.36" (60) Air (Peck) R-38100A 3.94" (100)	3	2	1,160	0.490	220
ES6-2-2425U	3,000		7/16	11	1/8	3	1/8	3	5.25							
ES6-2-2422U	2,700		15/32	12	5/32	4	5/32	4	5.83							
ES6-2-2417U	2,100		19/32	15	13/64	5	13/64	5	7.50							
ES6-2-2414U	1,700		45/64	18	1/4	6.5	15/64	6	9.27							
ES6-2-2411U	1,300		25/32	20	11/32	8.5	1/4	6.5	12.12							
ES6-4-2432U	3,800		5/16	8	3/32	2.5	3/32	2.5	2.76			2	4			
ES6-4-2425U	3,000		25/64	10	3/32	2.5	9/64	3.5	3.50							
ES6-4-2420U	2,400		15/32	12	11/64	4.5	11/64	4.5	4.38							
ES6-4-2417U	2,100		19/32	15	13/64	5	13/64	5	5.00							
ES6-4-2412U	1,500		5/8	16	9/32	7	9/32	7	7.00							
ES6-4-2411U	1,300		5/8	16	23/64	9	5/16	8	8.08							
ES6-4-2408U	1,000		45/64	18	7/16	11	27/64	10.5	10.50			1.5	6			
ES6-4-2407U	850		3/4	19	35/64	14	1/2	12.5	12.36							
ES6-4-2406U	650		25/64	20	5/8	16	19/32	15	16.16							
ES6-6-2426U	3,100		25/64	10	9/64	3.5	9/64	3.5	2.54							
ES6-6-2421U	2,500		15/32	12	11/64	4.5	11/64	4.5	3.15							
ES6-6-2417U	2,000		33/64	13	7/32	5.5	7/32	5.5	3.94							
ES6-6-2413U	1,600		35/64	14	9/32	7	9/32	7	4.92							
ES6-6-2412U	1,400		19/32	15	5/16	8	5/16	8	5.63							
ES6-6-2408U	1,000		5/8	16	7/16	11	7/16	11	7.88							
ES6-6-2407U	900		43/64	17	1/2	12.5	1/2	12.5	8.75							
ES6-6-2406U	700		3/4	19	5/8	16	35/64	14	11.25							
ES6-6-2405U	550		25/32	20	43/64	17	19/32	15	14.32							
ES6-6-2404U	450		7/8	22	3/4	19	43/64	17	17.51							

Note:

1. Model selection from the chart above based on workpiece specifications, material hardness, diameter of hole and cutting speed.
2. The drilling capacity shown above is for a depth equivalent of the drill diameter times two based on HSS tooling. For capacity beyond one spindle, see Multi-Spindle Head Catalog.
3. The maximum weight of any attachment for downward drilling is 110 lbs. For vertical down, a ram retention cylinder may be required.
4. Spindle and body air purge is available on all Electric units.

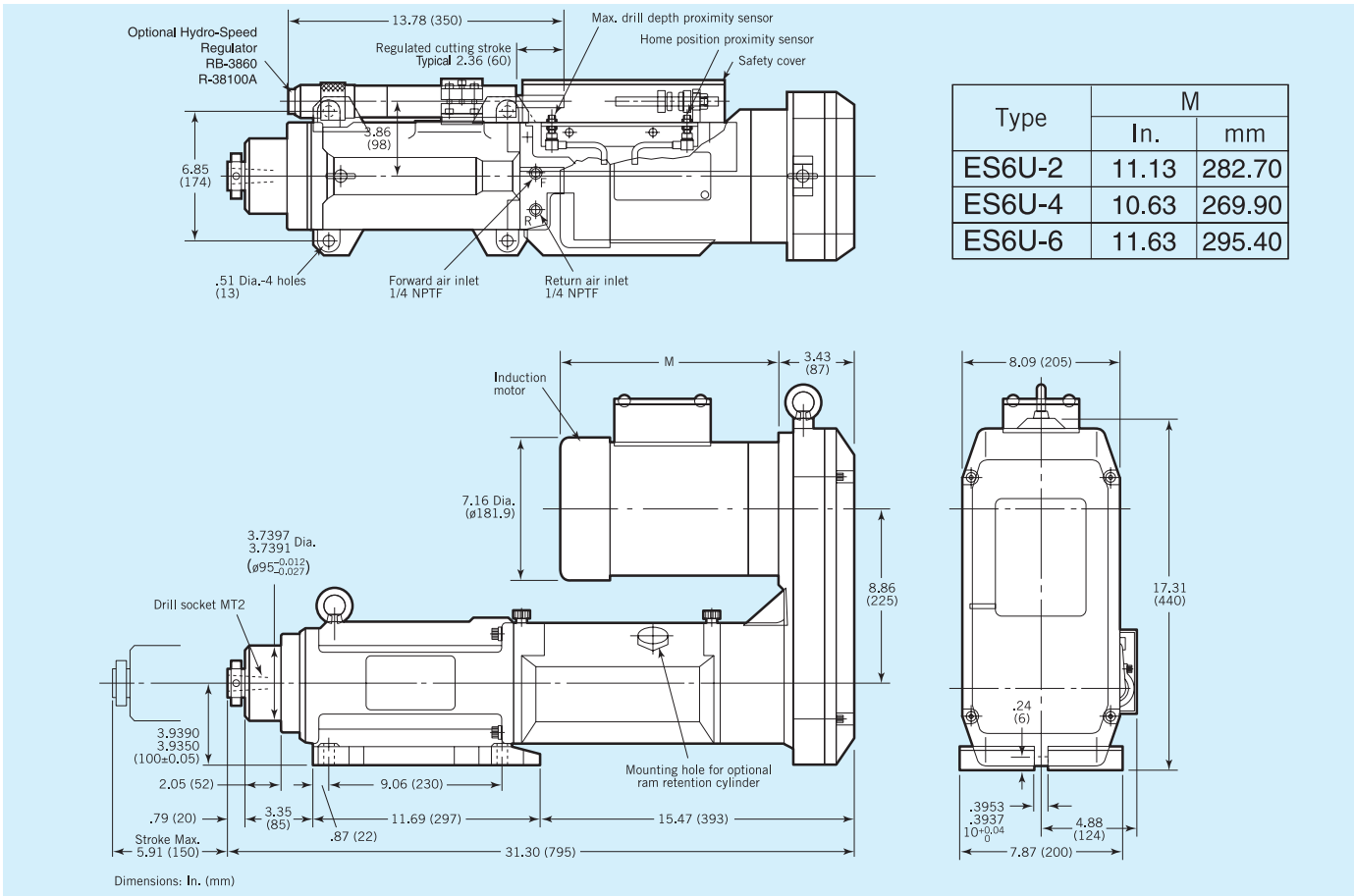

Type	M	
	In.	mm
ES6U-2	11.13	282.70
ES6U-4	10.63	269.90
ES6U-6	11.63	295.40

How To Order:

ES6-U SERIES

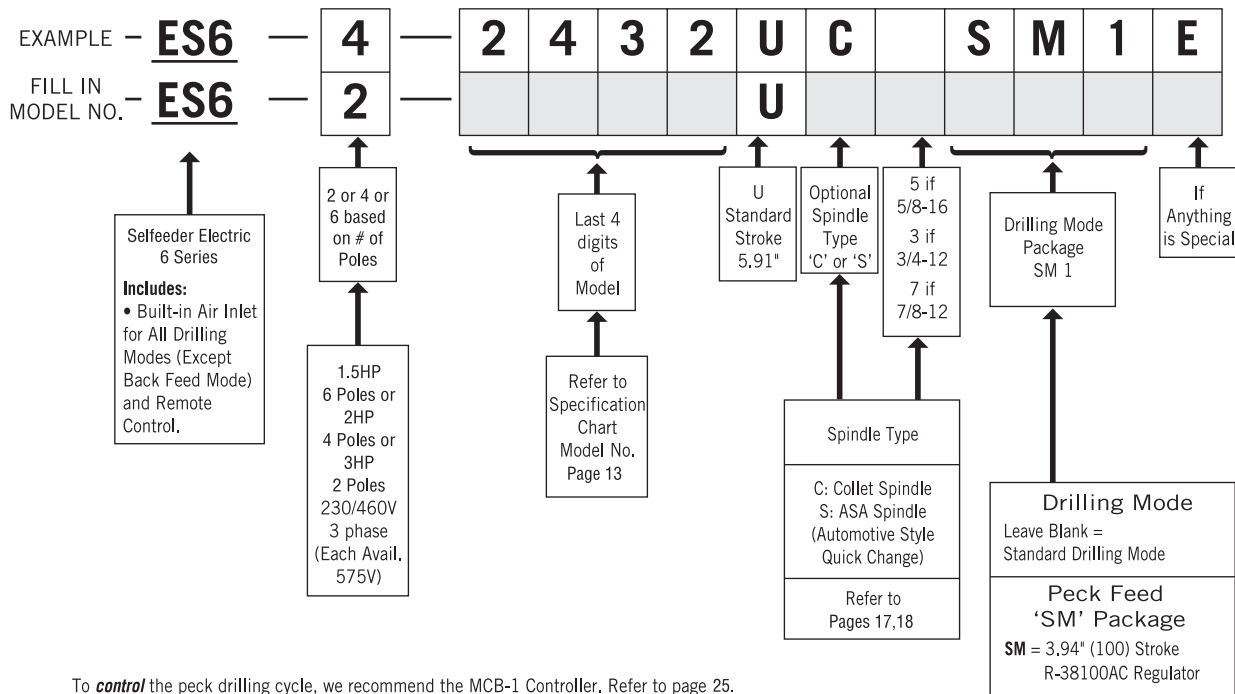

To **control** the peck drilling cycle, we recommend the MCB-1 Controller. Refer to page 25.
 ES6 is supplied without a valve block and manual auto return buttons. This Selffeeder has a built-in air inlet feature for forward & return strokes, suitable for use in the standard drilling mode or for remote and peck feed operation.
 • For Air Logic diagram to be used with ES6 refer to page 24.

selfeeder™ electric

ES7

Carbon Steel 1-7/64"

Aluminium 1-37/64"

Large unit with a maximum motor output of 7.5Hp and thrust of 2,104 lbs.

This type drills large-diameter holes 1-7/64" in Steel.

ES7

Selfeeder electric

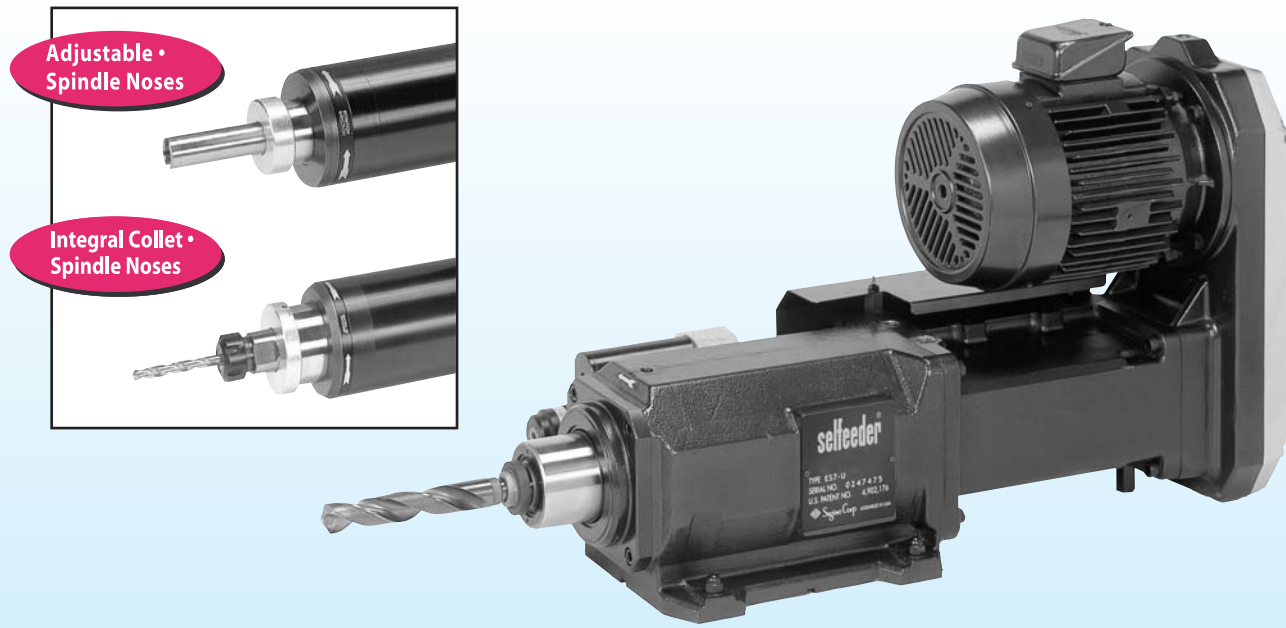

ES7-U Type Capacity Chart

Operating air pressure: 85 PSI

Specifications Model No.	Spindle RPM (no load) 60Hz min ⁻¹	Spindle Type	Typical Drill Size						Theoretical Spindle Torque Ft. Lbs.	Stroke		Motor		Thrust Lbs	Air Consumption Ft ³ /stroke	Weight Lbs
			Aluminum		Cast Iron		Mild Steel			max	Optional Feed Regulator	Output	No. of Poles			
			In	mm	In	mm	In	mm		In (mm)	In (mm)	Hp	P			
ES7-4P-3229U	3,500	MT2 or MT3	7/16	11	5/32	4	1/8	3	11.25	7.87" (200) Standard Stroke 'U'	Air R-55100A 3.94" (100) R-55150A 5.91" (150)	7.5	4	2,104	2.03	473
ES7-4P-3222U	2,700		33/64	13	13/64	5	5/32	4	14.59							
ES7-4P-3215U	1,800		43/64	17	9/32	7	15/64	6	21.88							
ES7-4P-3210U	1,200		1 9/64	29	25/64	10	23/64	9	32.83							
ES7-4P-3207U	900		1 27/64	36	33/64	13	15/32	12	43.77							
ES7-4-3229U	3,500		7/16	11	5/32	4	1/8	3	7.50							
ES7-4-3222U	2,700		33/64	13	13/64	5	5/32	4	9.73							
ES7-4-3215U	1,800		43/64	17	9/32	7	15/64	6	14.59							
ES7-4-3210U	1,200		63/64	25	25/64	10	23/64	9	21.88							
ES7-4-3207U	900		1 9/64	29	33/64	13	15/32	12	29.18							
ES7-4-3205U	600		1 19/64	33	3/4	19	45/64	18	43.77							
ES7-6-3226U	3,200		7/16	11	5/32	4	1/8	3	4.92							
ES7-6-3219U	2,300		35/64	14	13/64	5	5/32	4	6.85							
ES7-6-3215U	1,800		43/64	17	9/32	7	15/64	6	8.75							
ES7-6-3210U	1,200		25/32	20	35/64	14	15/32	12	13.13							
ES7-6-3206U	800		63/64	25	3/4	19	5/8	16	19.65							
ES7-6-3205U	600		1 7/32	31	61/64	24	53/64	21	26.26							
ES7-6-3203U	410		1 37/64	40	1 1/4	32	1 7/64	28	38.43							

Note:

1. Model selection from the chart above based on material hardness, diameter of hole and cutting speed (based on HSS tooling, dia. X 2).
2. The maximum weight of any attachment for downward drilling is 220 lbs. For vertical down, a ram retention cylinder may be required.
3. Optional spindle and body air purge is available on all Electric units.
4. Inquire to Sugino for capacities beyond one spindle.

Integral Collet Spindle

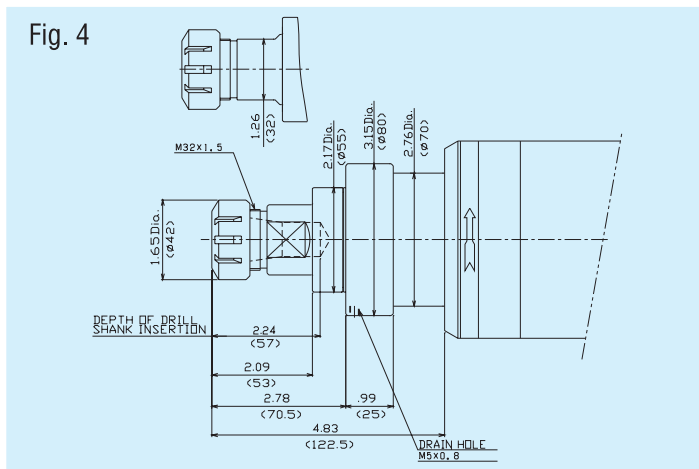
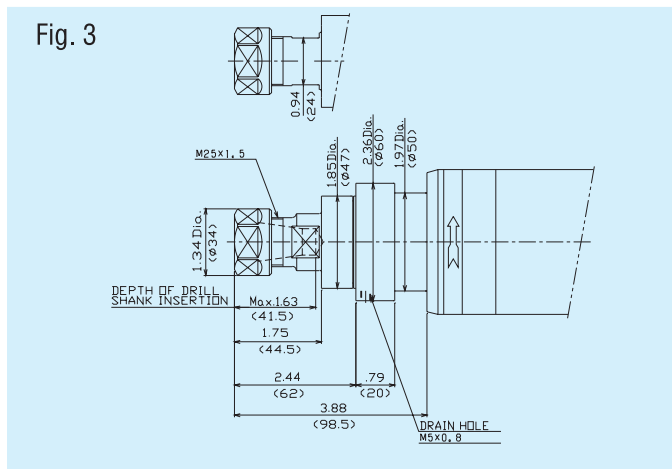
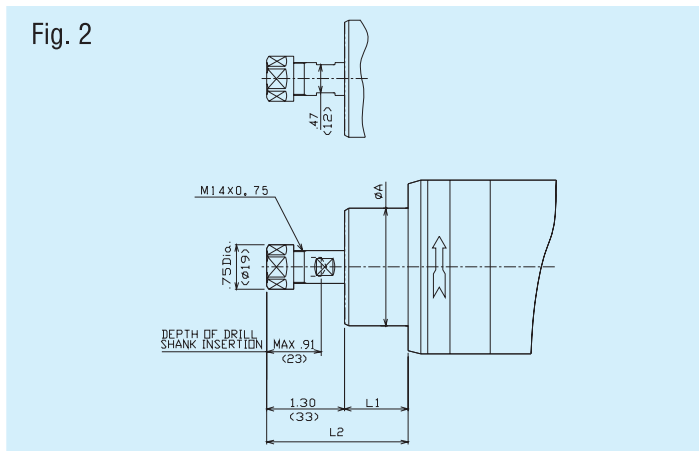
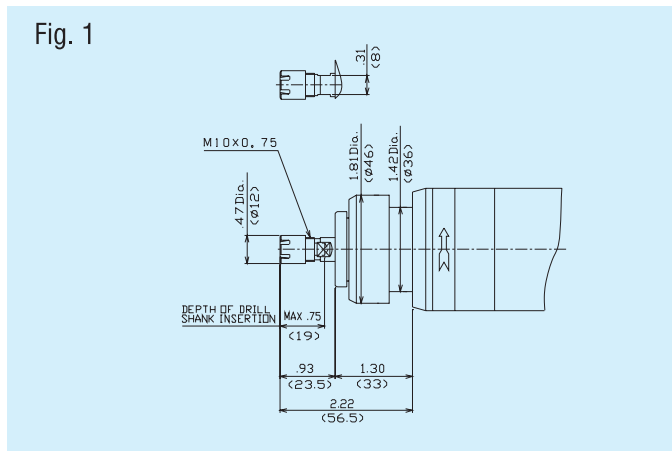

Integral Collet Spindle

Model No.	Fig.	Spindle Size	Chucking Capacity		L1		L2		A	
			In.	mm	In.	mm	In.	mm	In.	mm
ES2-U	1	ER8	0.0197 - 0.1969	0.5 - 5	-	-	-	-	-	-
ES3C-LU	3	ER20	0.0394 - 0.5118	1 - 13	-	-	-	-	-	-
ES3P 2-3075(60)L(LL)U 2-6054, 49, 43 L(LL)U	2	ER11	0.0197 - 0.2756	0.5 - 7	1.06	27	2.36	60	1.97	50
ES4P 2-6061(45) (L)U										
ES3P 2-6034(L)U 2-13**(L)U 4-13**(L)U	3	ER20	0.0394 - 0.5118	1 - 13	-	-	-	-	-	-
ES4P 2-13**(L)U 4-13**(L)U										
ES5 2-60**(L)U 2-13**(L)U 4-13**(L)U 6-13**(L)U	2	ER11	0.0197 - 0.2756	0.5 - 7	1.57	40	2.87	73	2.76	70
	4	ER25	0.0394 - 0.629	1 - 16	-	-	-	-	-	-
	5	ER32	0.0394 - 0.787	1 - 20	-	-	5.22	132.5	-	-
ES7	5	ER32	0.0394 - 0.787	1 - 20	-	-	5.72	145.5	-	-

NOTE: For ES7 model, ER40 available as special.
Drill unit collet, nut, wrench selection. See Page 29.

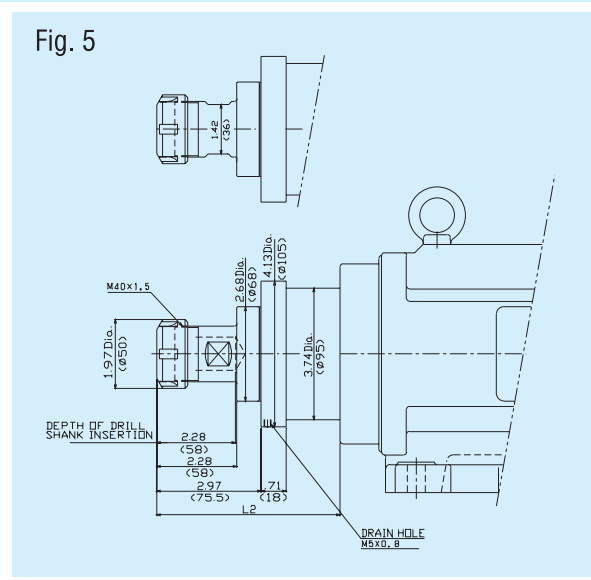

ASA Spindle Nose For Quick Change Tooling

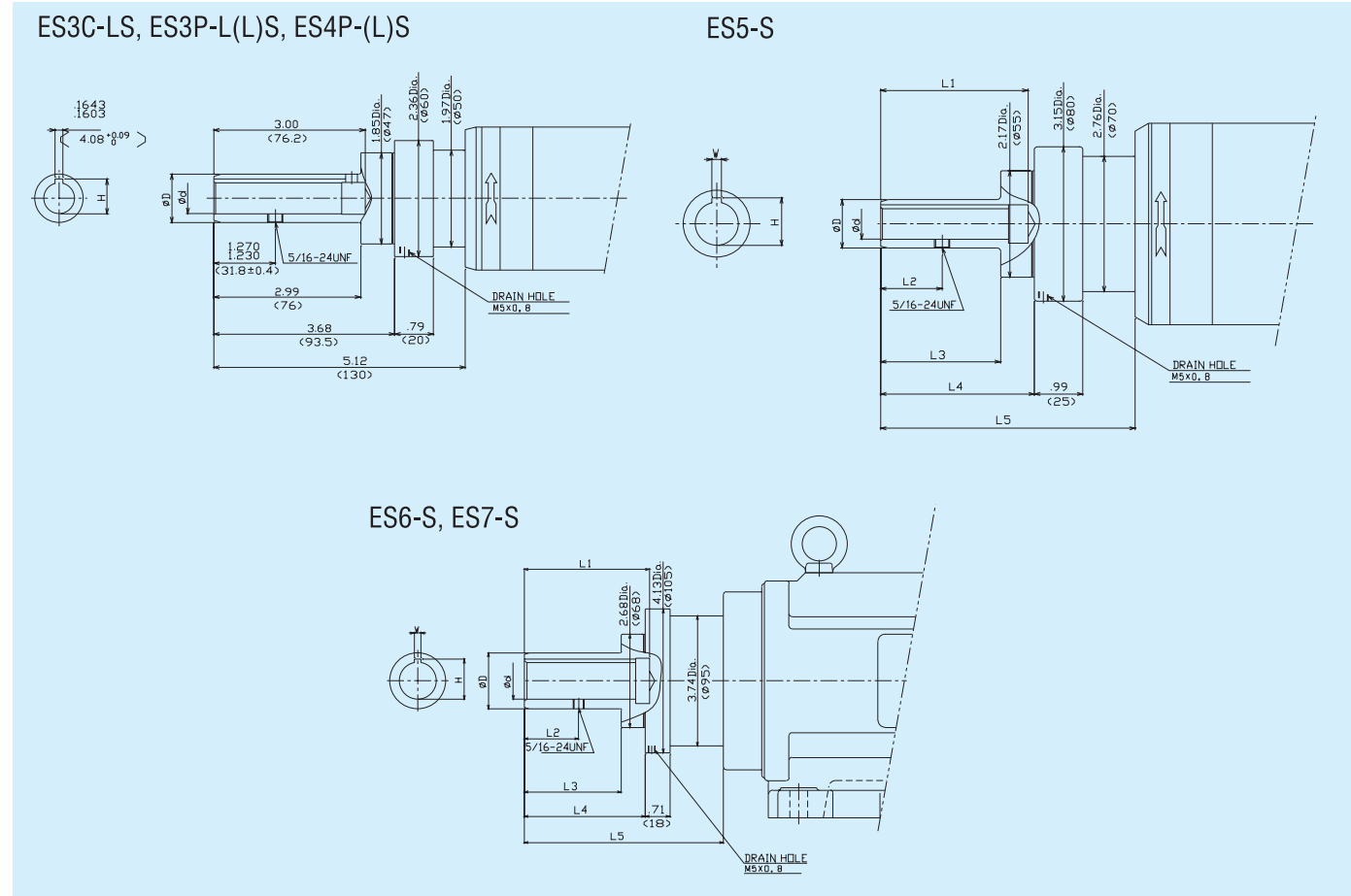

ASA Spindle Nose

Model No.	ASA Spindle Size	D		d		L2		L3		L4		L5		L1		W		H	
		In.	mm	In.	mm	In.	mm	In.	mm	In.	mm	In.	mm	In.	mm	In.	mm	In.	mm
ES3C-LS ES3P-L(L)S ES4P-(L)S	5/8-16	.985 .983	25.019 0 -0.050	.6255 .6250	15.875 +0.012 0	-	-	-	-	-	-	-	-	-	-	-	-	.7132 .7032	17.9 +0.2 0
	3/4-12	1.235 1.233	31.369 0 -0.050	.7505 .7500	19.050 +0.012 0	-	-	-	-	-	-	-	-	-	-	-	-	.8399 .8299	21.1 +0.2 0
	7/8-12	1.360 1.358	34.544 0 -0.050	.8755 .8750	22.225 +0.012 0	1.582 1.542	39.7±0.4	3.23	82	3.92	99.5	5.96	151.5	3.60	91.5	.1955 .1915	4.86 +0.1 0	.9785 .9685	24.6 +0.2 0
ES5-(L)S	5/8-16	.985 .983	25.019 0 -0.050	.6250	15.875 +0.012 0	1.270 1.230	31.8±0.4	2.44	62	3.13	79.5	5.18	131.5	3.00	76.2	.1643 .1603	4.08 +0.09 0	.7132 .7032	17.9 +0.2 0
	3/4-12	1.235 1.233	31.369 0 -0.050	.7505 .7500	19.050 +0.012 0	1.270 1.230	31.8±0.4	2.20	56	4.33	110	5.14	130.5	3.00	76.2	.1643 .1603	4.08 +0.09 0	.8399 .8299	21.1 +0.2 0
	7/8-12	1.360 1.358	34.544 0 -0.050	.8755 .8750	22.225 +0.012 0	1.582 1.542	39.7±0.4	2.80	71	3.48	88.5	5.73	145.5	3.60	91.5	.1955 .1915	4.86 +0.1 0	.9785 .9685	24.6 +0.2 0
ES6-S	3/4-12	1.235 1.233	31.369 0 -0.050	.7505 .7500	19.050 +0.012 0	1.270 1.230	31.8±0.4	2.20	56	4.33	110	5.14	130.5	3.00	76.2	.1643 .1603	4.08 +0.09 0	.8399 .8299	21.1 +0.2 0
	7/8-12	1.360 1.358	34.544 0 -0.050	.8755 .8750	22.225 +0.012 0	1.582 1.542	39.7±0.4	2.80	71	3.48	88.5	5.73	145.5	3.60	91.5	.1955 .1915	4.86 +0.1 0	.9785 .9685	24.6 +0.2 0
	1-1/16-12	1.610 1.608	40.894 0 -0.050	1.063 1.062	26.988 +0.012 0	1.063 1.062	39.7±0.4	2.80	71	3.48	88.5	6.24	158.5	3.60	91.5	.1955 .1915	4.86 +0.1 0	1.167 1.157	29.4 +0.2 0
ES7-S	1-1/16-12	1.610 1.608	40.894 0 -0.050	1.063 1.062	26.988 +0.012 0	1.063 1.062	39.7±0.4	2.80	71	3.48	88.5	6.24	158.5	3.60	91.5	.1955 .1915	4.86 +0.1 0	1.167 1.157	29.4 +0.2 0

NOTE: For ES6 and ES7 models, 1-3/8" ASA available as special.

Level Clamps

Level Clamps are used with the ES2, ES3C, ES3P, ES4P & ES5 Selffeeders. they provide a simple, accurate and secure Selfeeder attachment to the machine base. Crossing keyways on the bottom of the clamp provide accurate alignment.



Dimensions: Inches (mm)

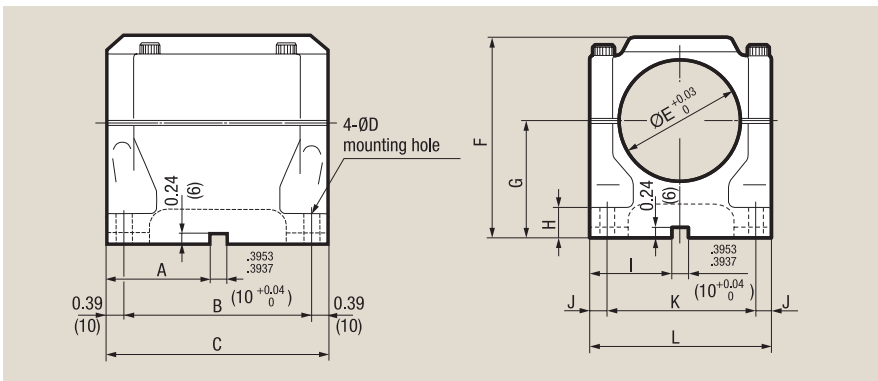

Dimensions: Inches (mm)

Model	A	B	C	D	E	F	G	H	I	J	K	L	Applicable Selffeeders
LC-52	1.18 (30)	1.97 (50)	2.75 (70)	.26 (6.5)	2.0484 2.0472 (52±0.03)	3.74 (95)	2.3630 2.3614 (60±0.02)	.55 (14)	1.38 (35)	.32 (8)	2.52 (64)	3.16 (80)	ES2
LC-74	2.36 (60)	4.33 (110)	5.11 (130)	.35 (9)	2.9156 2.9134 (74±0.03)	4.72 (120)	2.7567 2.7551 (70±0.02)	.71 (18)	1.96 (50)	.39 (10)	1.96 (90)	4.32 (110)	ES3C, ES3P
LC-92	2.56 (65)	4.72 (120)	5.51 (140)	.35 (9)	3.6236 3.6220 (92±0.03)	5.00 (127)	2.7567 2.7551 (70±0.02)	.79 (20)	2.40 (61)	.39 (10)	4.41 (112)	5.20 (132)	ES4P
LC-104	3.59 (90)	6.69 (170)	7.47 (190)	.43 (11)	4.0961 4.0945 (104±0.03)	5.83 (148)	3.1504 3.1488 (80±0.02)	.79 (20)	2.76 (70)	.39 (10)	5.12 (130)	5.91 (150)	ES5

Application example



Flex Stands The Flex stand is a jig for fixing a round-body type Selffeeder at a desired angle of operation.

Dimensions: Inches (mm)

Selffeeder	Part	Part No.	Dia. A	B	C	D	E	F	G	H	I	J	Keyway Width K	Keyway Height L	M	N	O	P	Q	R	S	T	U	V	W	X	Dia. Y		
ES2 FS-52	Base Support	FS-52BS	2.05 (52)	3.15 (80)								=2.78 (=70.7)	0.39 (10)	0.24 (6)	4.33 (110)	3.54 (90)		1.69 (43)	4.72 (120)	2.76 (70)	1.38 (35)	0.83 (21)	2.56 (65)	4.13 (105)			0.43 (11)		
	Swivel Support	FS-52SS	2.05 (52)	3.15 (80)	4.53 (115)	1.57 (40)					1.69 (43)																		
	Column Support	FS-52CS	2.05 (52)	3.15 (80)			4.72 (120)				1.69 (43)																		
	Parallel Support	FS-52PS	2.05 (52)	3.15 (80)							1.69 (43)																		
	Column	FS-52C	2.05 (52)						19.69 (500)																				
	Height Adjuster	US-52HA	2.05 (52)							1.18 (30)		2.05 (52)																	
ES3C & ES3P FS-74	Base Support	FS-74BS	2.91 (74)	4.33 (110)								=3.81 (=96.7)	0.39 (10)	0.24 (6)	4.72 (120)	3.94 (100)		2.20 (56)	5.51 (140)	3.54 (90)	1.38 (35)	0.87 (22)	2.95 (75)	4.91 (125)			0.43 (11)		
	Swivel Support	FS-74SS	2.91 (74)	4.33 (110)	5.31 (135)	1.77 (45)					2.20 (56)																		
	Column Support	FS-74CS	2.91 (74)	4.33 (110)			5.51 (140)				2.20 (56)																		
	Parallel Support	FS-74PS	2.91 (74)	4.33 (110)							2.20 (56)																		
	Column	FS-74C	2.91 (74)						23.62 (600)																				
	Height Adjuster	US-74HA	2.91 (74)							1.18 (30)		2.56 (65)																	
ES4P FS-92	Base Support	FS-92BS	3.62 (92)	6.30 (160)								=4.83 (=122.8)	0.39 (10)	0.24 (6)	5.75 (146)	4.72 (120)	1.38 (35)		2.87 (73)			1.10 (28)	5.71 (145)	6.69 (170)	2.95 (75)	0.43 (11)			
	Swivel Support	FS-92SS	3.62 (92)	6.30 (160)	8.46 (215)	2.36 (60)					2.76 (70)																		
	Column Support	FS-92CS	3.62 (92)	6.30 (160)			8.07 (205)				2.76 (70)																		
	Column	FS-92C	3.62 (92)						31.50 (800)																				
	Height Adjuster	US-92HA	3.62 (92)							1.34 (34)		3.07 (78)																	
ES5 FS-104	Base Support	US-104BC	4.09 (104)	7.84 (199)								=5.67 (=143.9)	0.39 (10)	0.24 (6)	6.93 (176)	6.93 (150)	1.57 (40)					1.34 (34)	6.89 (175)	7.87 (200)	3.54 (90)	0.43 (11)			
	Swivel Support	FS-92FS	4.09 (104)	7.84 (199)	9.84 (250)	2.76 (70)					3.03 (77)																		
	Column Support	US-104CC	4.09 (104)	7.84 (199)			9.76 (248)				3.03 (77)																		
	Column	FS-104C	4.09 (104)						39.37 (1000)																				
	Height Adjuster	US-104HA	4.09 (104)							1.50 (38)		3.74 (95)																	

Dimensions: Inches (mm)

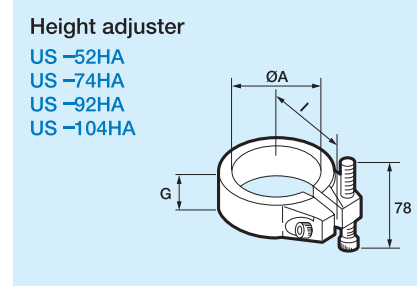
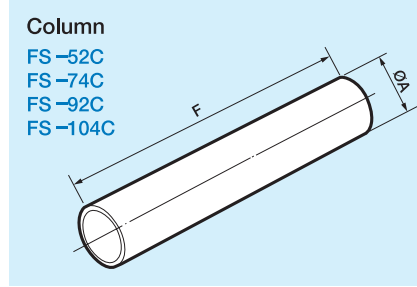
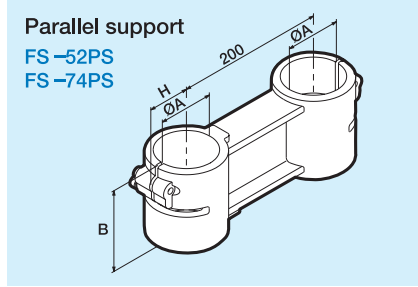
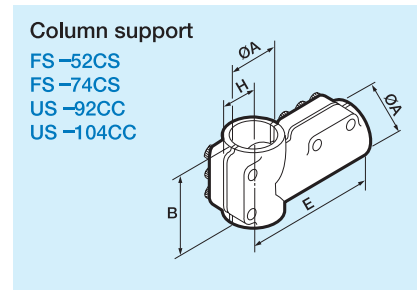
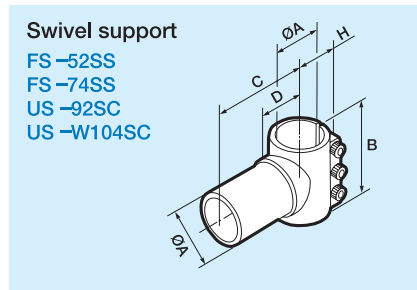
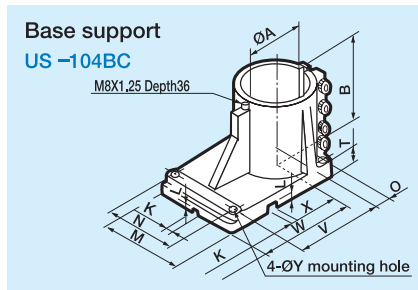
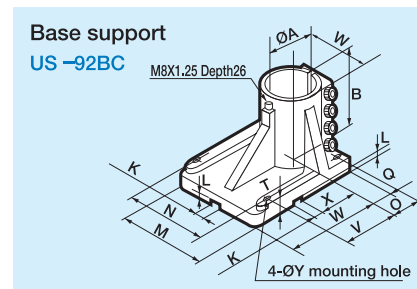
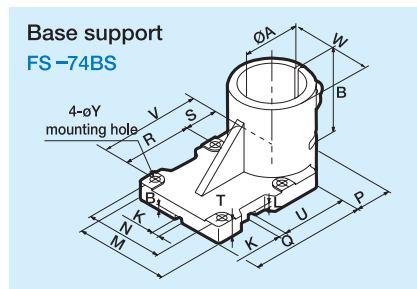
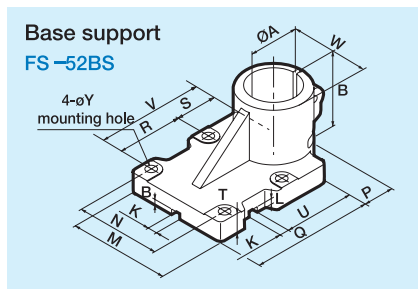

Hydro Speed Regulators

Hydro speed regulators are designed to control the forward speed (feed rate) of the Selfeeder. Use of a regulator provides adjustable feed rates, faster cycle times, reduces burring, eliminates drill breakage, and prevents sudden forward surges at drill breakthrough. One regulator is required per Selfeeder for drilling operations. Choose from the Spring-return type shown below or the Air-return type shown on page 22.

Spring Return Type 'RB'

Spring loaded regulators are used primarily for standard drilling operations and are designed to automatically return to their position at the end of every drilling cycle.



With the RB spring return regulator, the piston rod is automatically returned to its original position by the built-in spring when the piston rod is no longer loaded.

Features:

1. The Regulator is completely sealed to eliminate the need for resupplying the unit with operating oil and will provide stable speed control for many years of production.
2. Installation is easy. No need for piping or wiring.

Hydro Speed Regulators

Specifications

Model	Applicable Newtric Selfeeder	Max. Stroke in. (mm)	Load Range lbs. (kg)	Range of Speed Control for Each Thrust		Permissible Impact Load Ft. Lbs. (kg•m)	Wgt. (Main Body Only)
				in./sec.	(mm/sec)		
RB-2430	ES2	1.18 (30)	44 - 330	F = 44 Lbs. :.01 - .20	F = 20kg : 0.1 - 5	1.80 (0.25)	.90 (0.41)
RB-2460	ES3C	2.36 (60)	(20 - 150)	F = 110 Lbs. :.01 - 1.00	F = 50kg : 0.2 - 25		
	ES3P			F = 220 Lbs. :.02 - 1.57	F = 100kg : 0.3 - 40		
RB-3140	ES4P	1.57 (40)	110 - 660	F = 110 Lbs. :.01 - .40	F = 50kg : 0.1 - 10	2.90 (0.4)	2.09 (0.95)
RB-3160	ES5	2.36 (60)	(50 - 300)	F = 330 Lbs. :.01 - 1.00	F = 150kg : 0.2 - 25		
				F = 480 Lbs. :.02 - 1.38	F = 220kg : 0.3 - 35		
RB-3860*	ES6	2.36 (60)	480 - 990 (220 - 450)	F = 660 Lbs. :.02 - 1.57	F = 300kg : 0.5 - 40	4.30 (0.6)	3.96 (1.80)
				F = 480 Lbs. :.01 - .59	F = 220kg : 0.2 - 15		
				F = 840 Lbs. :.01 - .98	F = 380kg : 0.3 - 25		
				F = 990 Lbs. :.02 - 1.18	F = 450kg : 0.4 - 30		

Dimensions: Inches (mm)

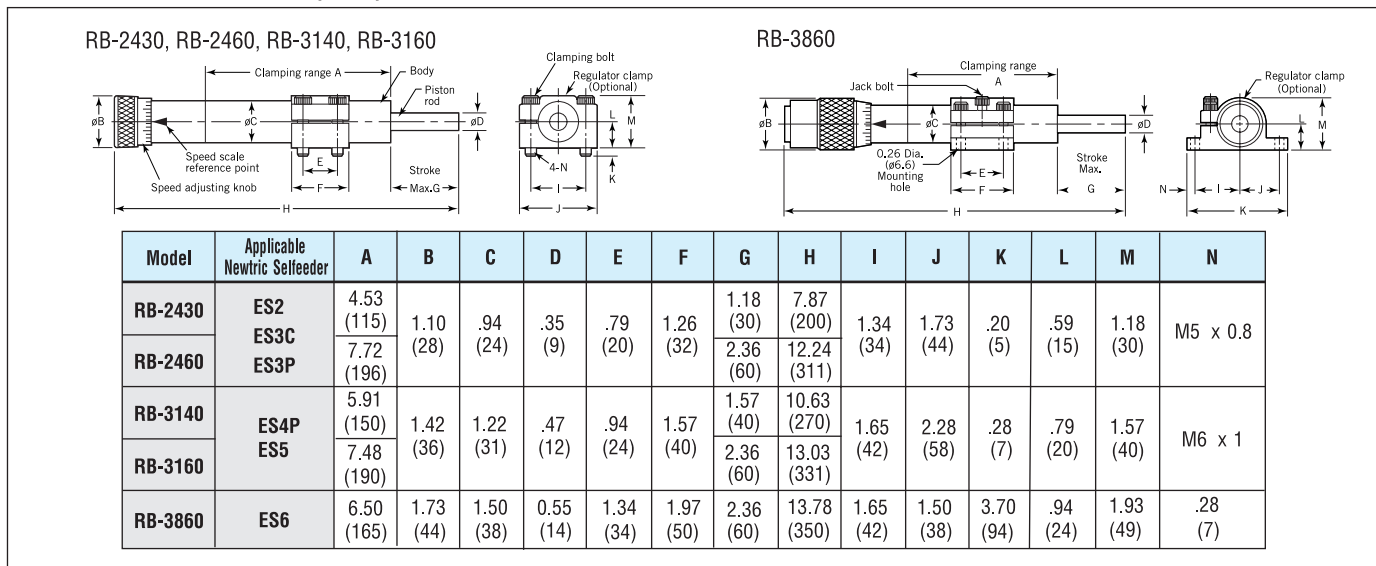

1. Clamping blocks for regulators are available as an option.

Ordering Example:

One 2.36" stroke Spring Return Regulator & Clamp for Model ES6 Selfeeder.

Qty. 1 - RB-3860 Regulator with Clamp

***Regulator Mounting Clamps sold separately.**

Air Return Type 'R'

'R' Air return regulators serve the same function as the spring return type in that they control the forward speed of the drill. However, the air type requires an air signal at the end of each drilling cycle to return the regulator to its original position. Also, these regulators are required for peck feed drilling as they are capable of holdin the drilling depth at the end of each peck feed motion.

Features:

1. With the position of the piston rod maintained along the stroke as desired, efficient peck feed drilling is possible.
2. Longer strokes available for extended application purposes.

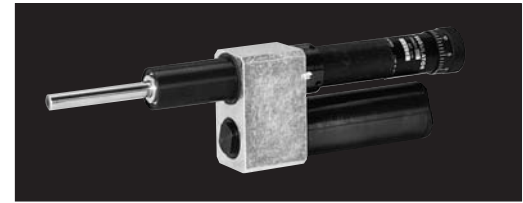

Ordering Example:

One 3.15" stroke Air Return Regulator for Model ES2 Selffeeder.

Qty. 1 - R-3182A Air Return Regulator.

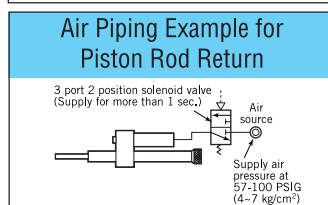
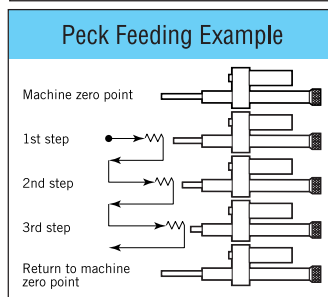
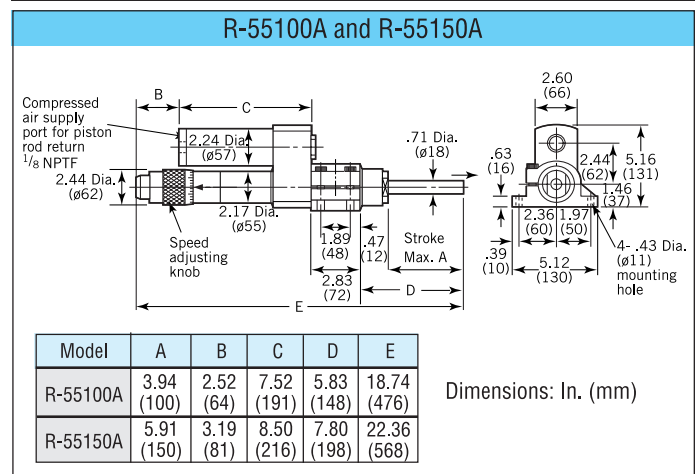
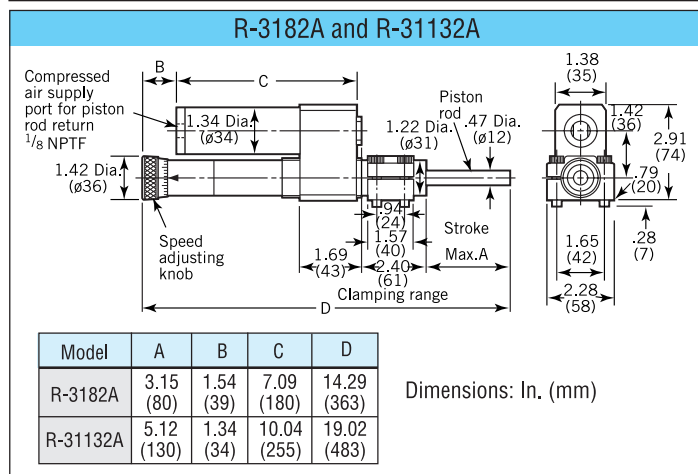
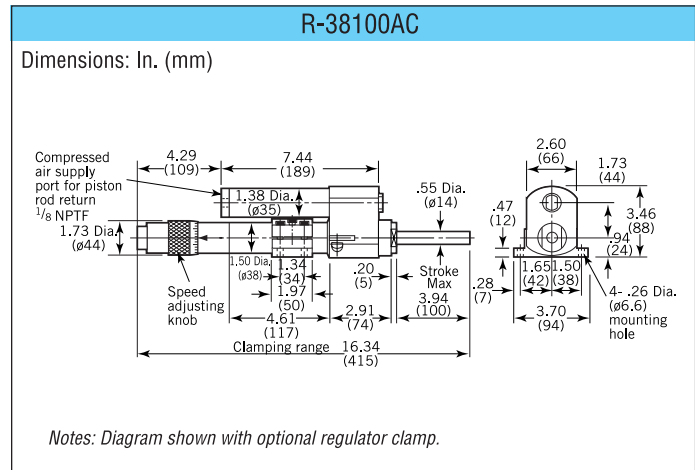
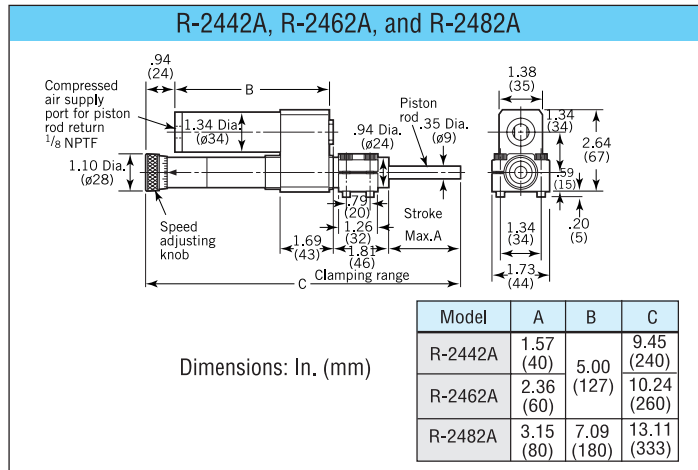

Specifications

Model	Applicable Selffeeder	Max. Stroke in. (mm)	Load Range Lbs. (kg)	Range of Speed Control for Each Thrust		Permissible Impact Load Ft. Lbs. (kg·m)	Wgt. (Main Body Only)
				in./sec.	(mm/sec)		
R-2442A	ES2 ES3C ES3P	1.57 (40)	44 - 330 (20 - 150)	F = 44 Lbs. : .01 - .20	F = 20kg : 0.3 - 5	1.80 (0.25)	2.86 (1.3)
R-2462A		F = 220 Lbs. : .02 - .98		F = 100kg : 0.5 - 25	3.08 (1.4)		
R-2482A		F = 330 Lbs. : .03 - 1.18		F = 150kg : 0.8 - 30	3.30 (1.5)		
R-3182A	ES4P ES5	3.15 (80)	110 - 660 (50 - 300)	F = 220 Lbs. : .01 - .47	F = 100kg : 0.3 - 12	2.90 (0.4)	4.85 (2.2)
R-31132A		F = 480 Lbs. : .02 - .98		F = 220kg : 0.5 - 25	6.17 (2.8)		
R-38100AC*	ES6	3.94 (100)	480 - 990 (220 - 450)	F = 480 Lbs. : .01 - .59	F = 220kg : 0.3 - 15	4.30 (0.6)	9.26 (4.2)
R-55100A*		F = 840 Lbs. : .02 - .98		F = 380kg : 0.5 - 25	7.20 (1.0)		16.09 (7.3)
R-55150A*		F = 990 Lbs. : .03 - 1.18		F = 450kg : 0.8 - 30			17.86 (8.1)

*R-38100A, R-55100A, R-55150A Regulator Clamps sold separately

Air Logic Diagram & Electrical Schematic

Standard Valve Block

Standard Selfeeder valve blocks contain an internal spool valve for changing direction, manual start and return buttons, auto return button, forward and reverse flow control valves and an air silencer.

Standard Types

- ES2
- ES3C
- ES3P
- ES4P
- ES5

Drive Circuit Diagram

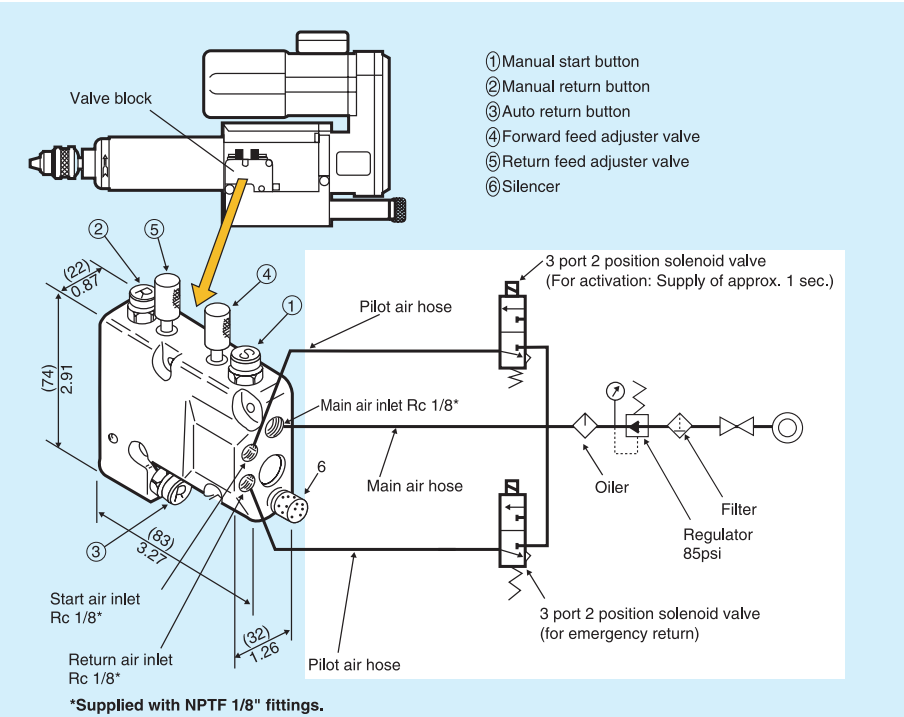

Air Logic Diagram & Electrical Schematic

Electrical Schematic (Typical)

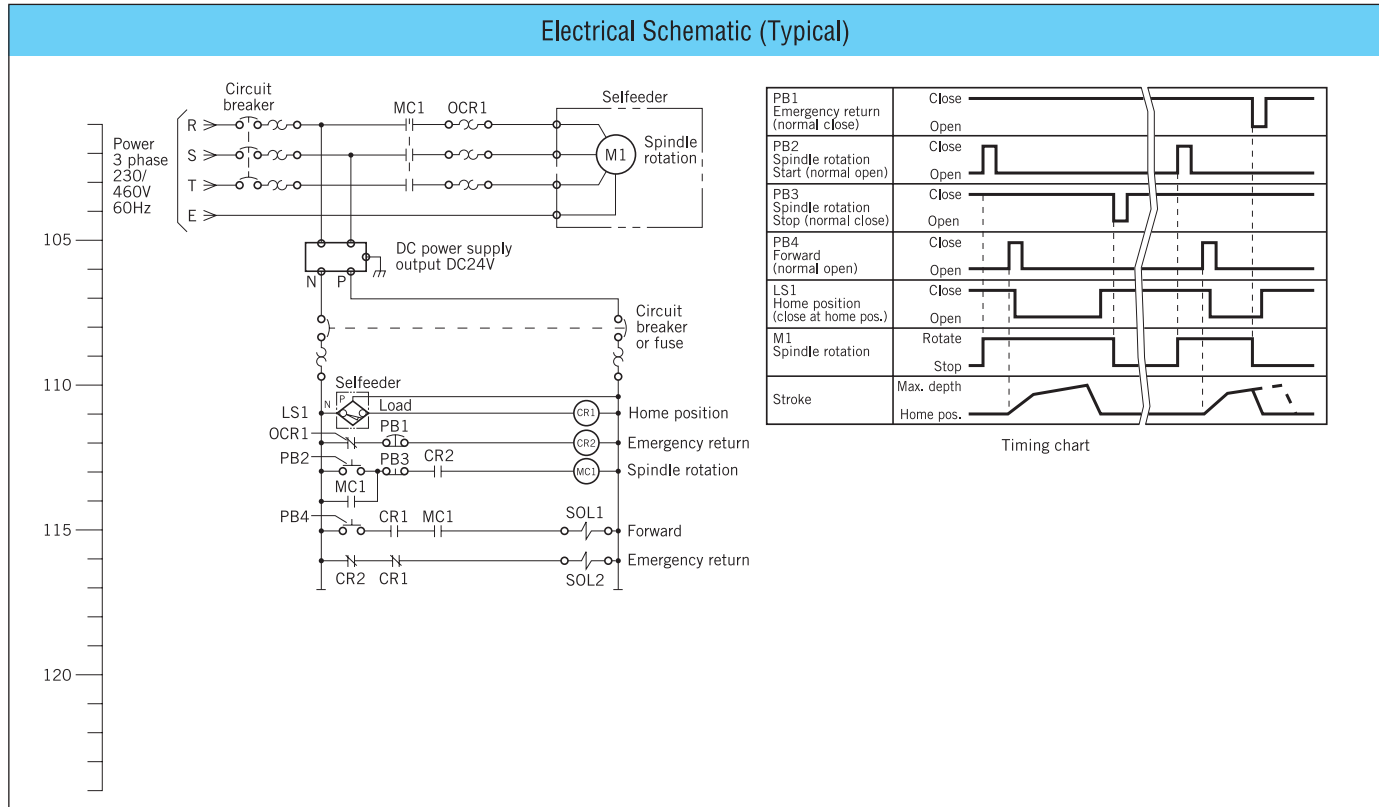

Economy Valve Block (A)

Specify this valve block when you need remote control operations and peck feed drilling. For use with all models of electric Selffeeders.

Economy type 'A' blocks are designed for economic efficiency, with a simplified control mechanism eliminating the forward and return buttons for manual operation.

E.g.: ES3C-2A-6022LU
ES5-4A-1326U

Economy Types

- ES2 ES4P
- ES3C ES5
- ES3P

- Notes
1. Be sure to use the meter-in flow control valve to control the speed in forward and return movement for the ES2 to the ES5.
 2. Use a meter-in flow control valve with the ES6 and a meter-out flow control valve with the ES7.
- Refer to the drive circuit diagram for the valveless type.

Drive Circuit Diagram

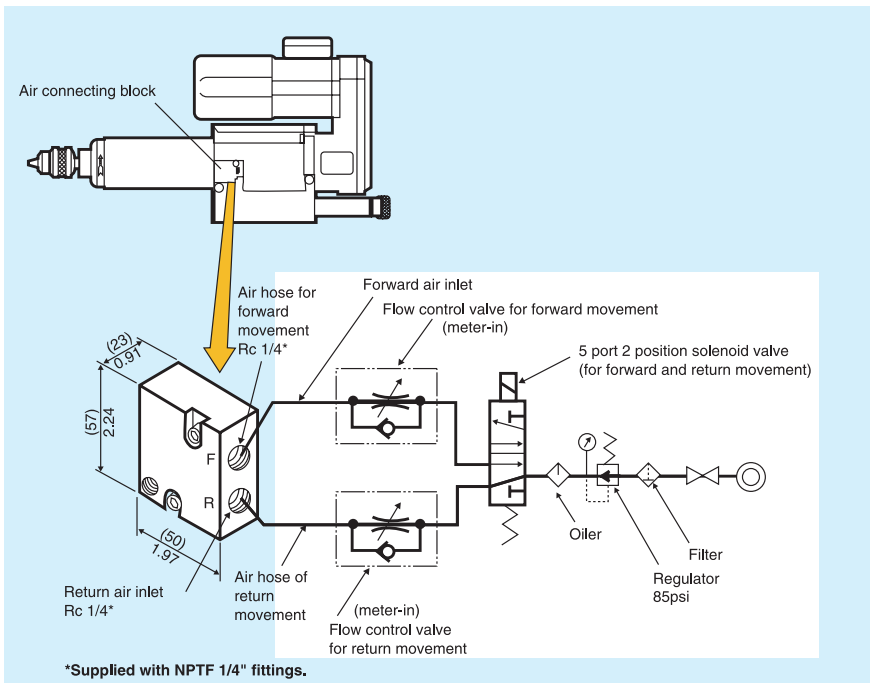

Electrical Schematic (Typical)

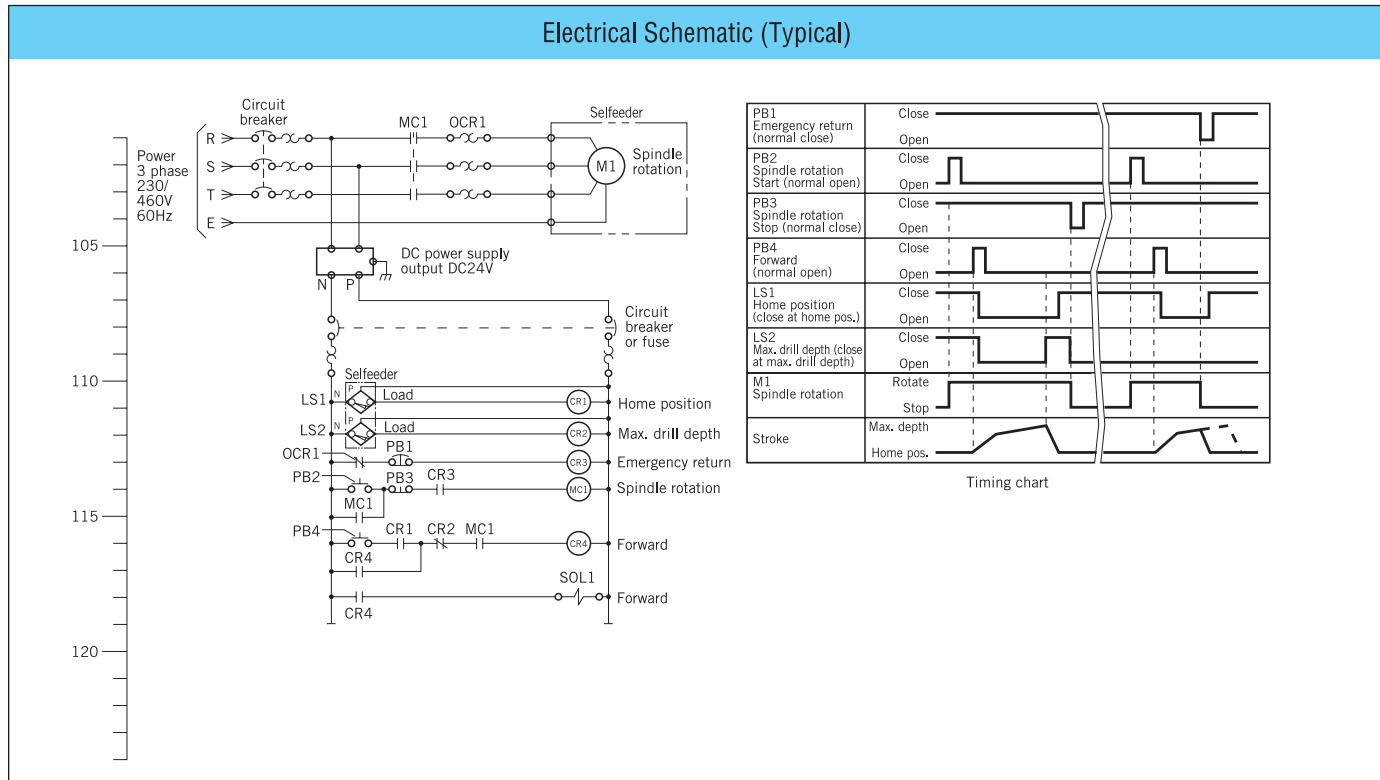

'SM' Package Air Logic Diagram & Electrical Schematics for Peck Feed Drilling with MCB-1 Controller

'SM' Package Air Logic Diagram & Electric Schematics

By specifying the optional 'SM' package for peck feed drilling on Models ES2, ES3C, ES3P, ES4P, ES5, ES6 or ES7 they will be supplied with 'A' valve blocks if applicable, OSK signal kit and air return hydro speed regulators.

Order MCB-1 controller page 25 to control peck motion; or supply your own logic control (PLC).

Electric and air circuit

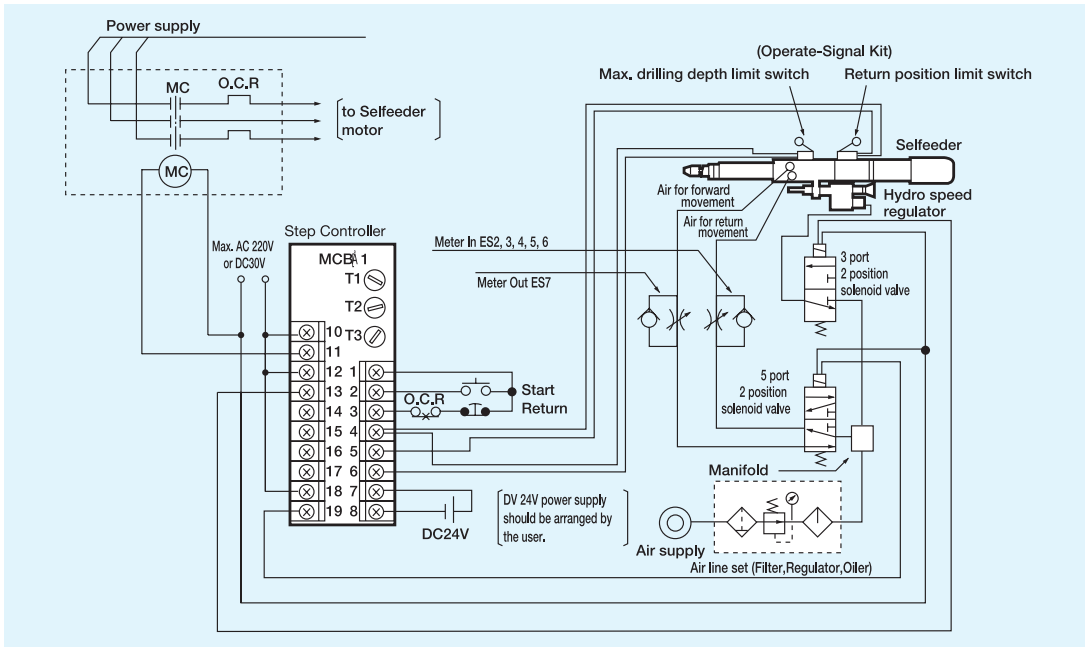

- Notes
1. The solenoid valves in the above application are designed for AC200V. Transformer (200V-100V) is required for AC100V use.
 2. The solenoid valve and Operate-Signal Kit above application are not attached with the step controller MCB-1 as standard accessories. Other air devices are to be provided by customer.

Electrical Schematic for MCB-1 (Typical)

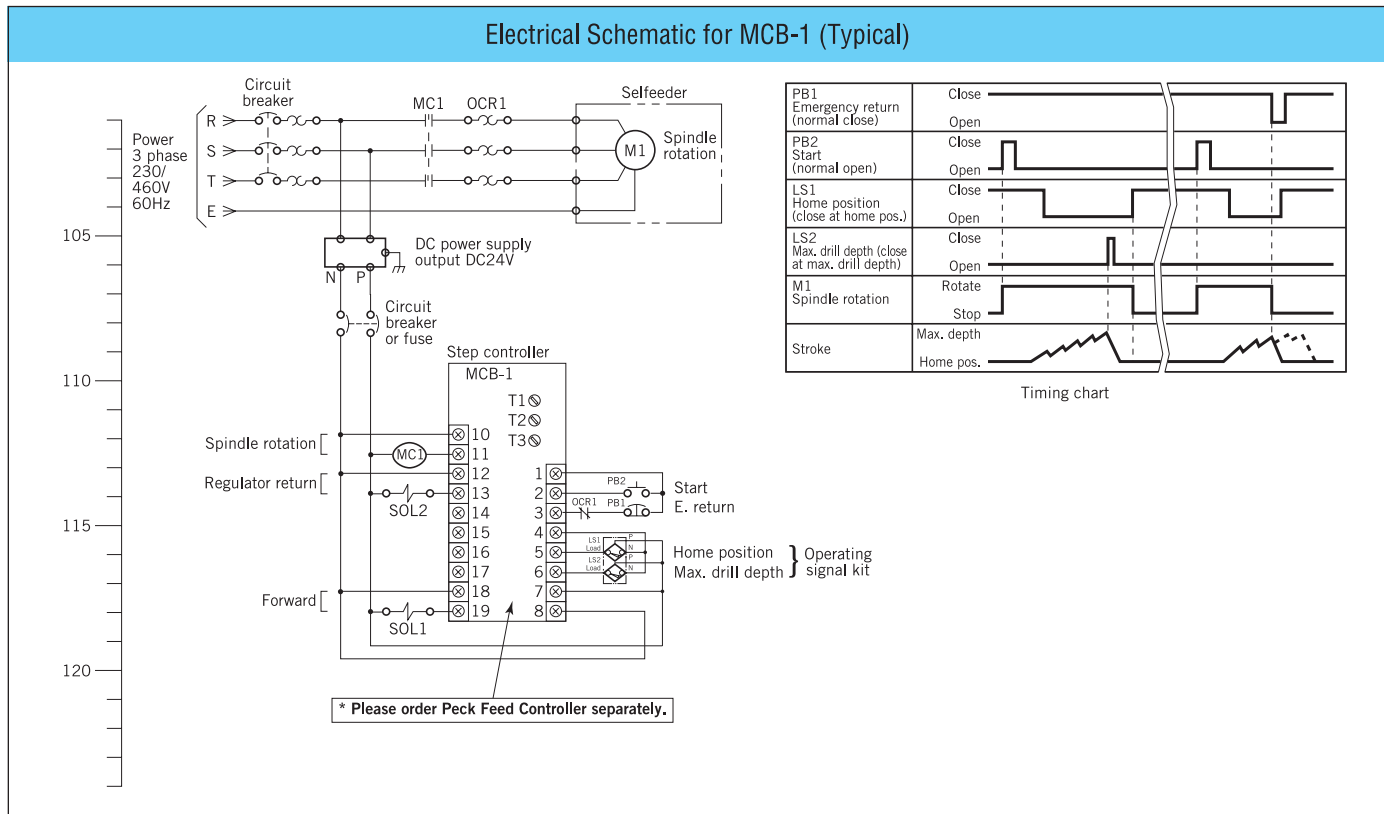

Operating Signal Kits (OSK)

Sugino recommends the use of proximity sensor Operating Signal Kits (OSK) to control Electric II Selfeeder working positions and to provide the signals necessary for sequencing them with other operations and equipment in semi-automated or fully automated environments. These OSK's mount easily to the Selfeeder and have a cable-to-sensor quick connect feature for ease of placement.

Proximity sensors are entirely solid state electronic controls which provide rapid response and high switching rates. They contain no moving parts, require no physical contact for actuation, and have no cams or linkage. They are completely encapsulated, making them impervious to most liquids, chemicals, cutting oils and coolants, high temperature variations, and vibrations.

Order a single sensor OSK to detect home position (return position) only, or a two sensor kit to detect both home and maximum drill depth positions.

Applicable Selfeeder Type	OSK Part No.	Detection Point	Proximity Sensor Specifications
ES2 ES3CL ES3PL	OSK-80-EX (1 -sensor) (1 -dog)	Home position	Sensing distance = .059" (1.5 mm) Provided Standard NPN (current-sinking) Normally open
	OSK-80-WX (2-sensors) (2-dogs)	Max. drilling depth & home position	
ES4P ES5	OSK-100-EX (1 -sensor) (1 -dog)	Home position	By Request Optional PNP (current sourcing) Normally Open add(P)
	OSK-100-WX (2 -sensors) (2 -dogs)	Max. drilling depth & home position	
ES3PLL	OSK-150-EX (1 -sensor) (1 -dog)	Home position	Operating voltage 10-30 V DC
	OSK-150-WX (2-sensors) (2-dogs)	Max. drilling depth & home position	
ES4PL	OSK-200-EX (1-sensor) (1 -dog)	Home position	Disconnect cable, 16.4' (5m) long
	OSK-200-WX (2-sensors) (2-dogs)	Max. drilling depth & home position	
ES6	OSK-150N6-WX (2-sensors) (2-dogs)	Max. drilling depth & home position	3 Wire type with 2 LED's.
ES7	OSK-200N7-WX (2-sensors) (2-dogs)	Max. drilling depth & home position	

Home Position

- OSK-80-EX (ES2/ES3C-L/ES3PL)
- OSK-100-EX (ES4P/ES5)
- OSK-150-EX (ES3PLL)

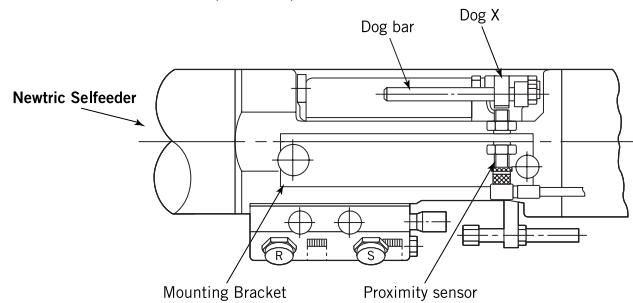

Max. Drilling Depth & Home Position

- OSK-80-WX (ES2/ES3C-L/ES3PL)
- OSK-100-WX (ES4P/ES5)
- OSK-150-WX (ES3PLL)

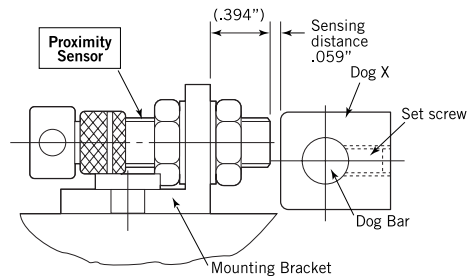
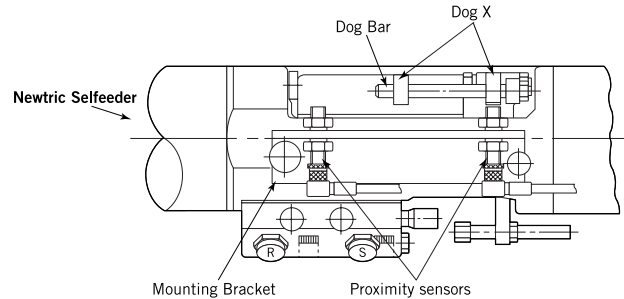

One operating signal kit includes the following:

- Proximity Sensor(s)
- Dog Bar (1)
- Electrical Cable(s)
- Dog(s)
- Mounting Bracket (1)
- Lock Nuts
- Thumb Screw (1)

Wiring Connections

DC-PNP Type Wiring Diagrams

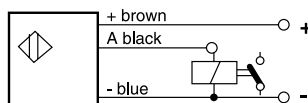

PNP (Current Sourcing) type output - Load common connects to (-) negative line, sensor switches (+) positive line. Normally open (make) function N/O.

NPN (Current Sinking) type output - Load common connects to (+) positive line, sensor switches (-) negative line. Normally open (make) function N/O.

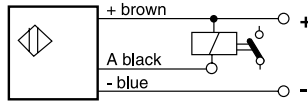

DC-NPN Type Wiring Diagrams

Ordering Example:

Proximity Sensor OSK for ES5 Selfeeder to provide signals at both home position and max. drill depth.

Qty. 1 - OSK-100-WX Proximity Kit.

Note: Operating Signal Kits (OSK) are also available with pneumatic switches or micro (contact) switches. Please contact Sugino Corp.

Drill Chucks, Collet Chucks & Micro Stopper

Key style drill chucks are standard with Electric Selffeeders ES2, ES3C, ES3P, ES4P, and ES5.

Keyless Drill Chucks: • Improve run out • Eliminate chuck keys

Collet Chucks: • Excellent run out control • Stronger holding force • Stop-Screw type Collet Chucks provide tool length adjustability

Drill Chuck

Standard • *Not recommended for ES2 at 7200, 10,000, 12,000 RPM or ES3P at 7200 & 9000 RPM

Applicable to Electric Models	Chuck Cap		Jacobs Taper T	A		B		Sugino Part No.	Chuck Key Part No.
	In.	mm		In.	mm	In.	mm		
ES2, ES3C, ES3P, ES4P, ES5-60 Type	0-1/4	0-6.5	JT1	1.95	49.5	1.26	32	830002	830007
ES2, ES3C, ES3P, ES4P, ES5-13 Type	5/64-1/2	2-13	JT33	3.03	77	1.77	45	830003	830008

Ordering Example: One Drill Chuck & Chuck Key for 3/8" drill for Model ES3P Selffeeder with JT33 Spindle.

Qty. 1 - 830003 Drill Chuck and 830008 Chuck Key

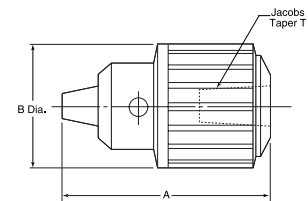

Keyless Drill Chuck

Optional • *Standard supply for ES2 at 7200, 10,000, 12,000 RPM and ES3P at 7200 & 9000 RPM

Applicable to Electric Models	Chuck Cap		Jacobs Taper T	A		B		Sugino Part No.
	In.	mm		In.	mm	In.	mm	
ES2-30 & 31, ES3P-30 & 60, ES4P 60 Type	0-1/8	0-3	JT1	1.89	48	.94	24	830040
ES2, ES3P, ES4P-30 & 60 Type	0-1/4	0-6.5	JT1	2.68	68	1.34	34	830043
ES3C, ES3P, ES4P, ES5-13 Type	1/32-1/2	1-13	JT33	4.06	103	1.97	50	830048

Ordering Example: One Keyless Drill Chuck for Model ES3P Selffeeder with JT33 spindle for 3/8" drill

Qty. 1 - 830048 Keyless Drill Chuck

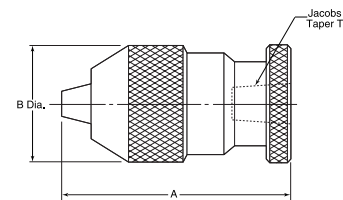

Collet Chuck JT1 Taper

Collet Optional

Applicable to Electric Models	Chuck Cap (C)		Jacobs Taper T	A		B		Collet Type	Sugino Part No.	Nose Piece
	In.	mm		In.	mm	In.	mm			
ES2, ES3P, ES4P, ES5-30 or 60 Type	1/64-1/4	0.5-6.3	JT1	2.19	55.6	.87	22	300DA	J11DA301219	NPA304

Ordering Example: One Collet Chuck for 1/4" drill for Model ES2 Selffeeder with JT1 spindle.

Qty. 1 - J11DA301219 Collet Chuck

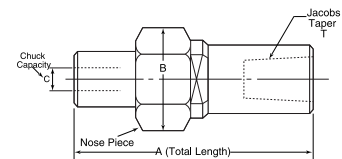

Collet Chuck with Length Adj. Stop Screw JT33 Taper

Collet Optional

Applicable to Electric Models	Chuck Cap (C)		Jacobs Taper T	A		B		Stop Screw Adj. Range Min/Max.	Collet Type	Sugino Part No.	Nose Piece	
	In.	mm		In.	mm	In.	mm					
ES3C, ES3P, ES4P, ES5-13 Type	1/8-3/8	3-9.5	JT33	3.62	92	1.44	36.6	1.69/2.00	43/50	200DA	J133DA201362	NPA204

Ordering Example: One Collet Chuck with a length adjustment screw for 1/8" drill for Model ES3C Selffeeder with JT33 spindle taper.

Qty. 1 - J133DA201362 Collet Chuck

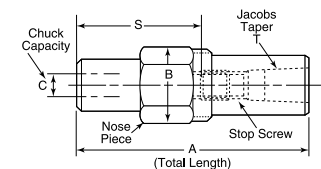

Collet Chuck JT 33 Taper

Collet Optional

Applicable to Electric Models	Chuck Cap (C)		Jacobs Taper T	A		B		Collet Type	Sugino Part No.	Nose Piece
	In.	mm		In.	mm	In.	mm			
ES3C, ES3P, ES4P, ES5-13 Type	1/8-3/8	3-9.5	JT33	2.69	68.3	1.15	29.2	200DA	J133DA208269	NPA204
	1/4-9/16	6.3-14.2	JT33	3.19	81	1.44	36.6	100DA	J133DA108319	NPA104
	1/4-3/4	6.3-19	JT33	3.34	84.8	1.73	44	180DA	J133DA188334	NPA188

Ordering Example: One Collet chuck for 3/4" drill Model ES5 Selffeeder with JT33 Spindle taper.

Qty. 1 - J133DA188334 Collet Chuck

Note:
1. Collet chucks are supplied with a nose piece.
2. Order collets separately. Refer to page (31).

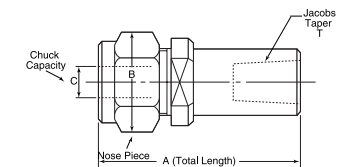

Micro-Stopper

For Selffeeder Models ES2, ES3C, ES3P, ES4P and ES5 standard depth repeatability is $\pm 0.004"$ (± 0.1 mm). By replacing the auto-return button on the standard type valve block of the Selffeeder with a Micro Stopper, depth repeatability of $\pm 0.0008"$ (± 0.02 mm) can be achieved.

Ordering Example: One Micro Stopper to achieve $\pm 0.0008"$ depth repeatability on Model ES5 Selffeeder.

Qty. 1 - SFPMS Microstopper

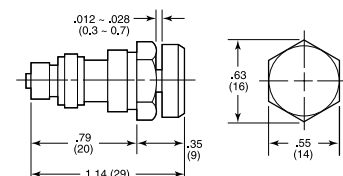

Drill Chucks, Collet Chucks & Micro Stopper

Collets Optional Accessories

ER Collets for Integral Collet Spindle Units

Collets

PART NO		SIZE	PART NO		SIZE	PART NO		SIZE	PART NO		SIZE	PART NO		SIZE			
ER 40 SERIES			ER 25 SERIES			ER 20 SERIES			ER 16 SERIES			ER 11 SERIES			ER 8 SERIES		
RF140030	.1181		RF125010	.0393	RF120010	.0393	RF116010	.0393	RF111010	.0393	RF108010	.0393					
RF140035	.1377		RF125015	.0590	RF120015	.0590	RF116015	.0590	RF111015	.0590	RF108015	.0590					
RF140040	.1574		RF125020	.0787	RF120020	.0787	RF116020	.0787	RF111020	.0787	RF108020	.0787					
RF140045	.1771		RF125025	.0984	RF120025	.0984	RF116025	.0984	RF111025	.0984	RF108025	.0984					
RF140050	.1968		RF125030	.1181	RF120030	.1181	RF116030	.1181	RF111030	.1181	RF108030	.1181					
RF140055	.2165		RF125035	.1377	RF120035	.1377	RF116035	.1377	RF111035	.1377	RF108035	.1377					
RF140060	.2362		RF125040	.1574	RF120040	.1574	RF116040	.1574	RF111040	.1574	RF108040	.1574					
RF140065	.2559		RF125045	.1771	RF120045	.1771	RF116045	.1771	RF111045	.1771	RF108045	.1771					
RF140070	.2755		RF125050	.1968	RF120050	.1968	RF116050	.1968	RF111050	.1968	RF108050	.1968					
RF140075	.2952		RF125055	.2165	RF120055	.2165	RF116055	.2165	RF111055	.2165							
RF140080	.3149		RF125060	.2362	RF120060	.2362	RF116060	.2362	RF111060	.2362							
RF140085	.3346		RF125065	.2559	RF120065	.2559	RF116065	.2559	RF111065	.2559							
RF140090	.3543		RF125070	.2755	RF120070	.2755	RF116070	.2755	RF111070	.2755							
RF140095	.3740		RF125075	.2952	RF120075	.2952	RF116075	.2952									
RF140100	.3937		RF125080	.3149	RF120080	.3149	RF116080	.3149									
RF140105	.4133		RF125085	.3346	RF120085	.3346	RF116085	.3346									
RF140110	.4330		RF125090	.3543	RF120090	.3543	RF116090	.3543									
RF140115	.4527		RF125095	.3740	RF120095	.3740	RF116095	.3740									
RF140120	.4724		RF125100	.3937	RF120100	.3937	RF116100	.3937									
RF140125	.4921		RF125105	.4133	RF120105	.4133											
RF140130	.5118		RF125110	.4330	RF120110	.4330											
RF140135	.5314		RF125115	.4527	RF120115	.4527											
RF140140	.5511		RF125120	.4724	RF120120	.4724											
RF140145	.5708		RF125125	.4921	RF120125	.4921											
RF140150	.5905		RF125130	.5118	RF120130	.5118											
RF140155	.6102		RF125135	.5314													
RF140160	.6299		RF125140	.5511													
RF140165	.6496		RF125145	.5708													
RF140170	.6693		RF125150	.5905													
RF140175	.6890		RF125155	.6102													
RF140180	.7087		RF125160	.6299													
RF140185	.7283																
RF140190	.7480																
RF140195	.7677																
RF140200	.7874																
RF140205	.8071																
RF140210	.8268																
RF140215	.8465																
RF140220	.8661																
RF140225	.8858																
RF140230	.9055																
RF140235	.9252																
RF140240	.9449																
RF140245	.9646																
RF140250	.9843																
RF140260	1.0036																
RF140270	1.063																
RF140280	1.1024																
RF140290	1.1417																

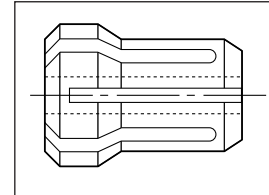

Contact Sugino

Series 300 (DA Style) Collets
Available 1/32" ~ 1/4"

Series 200 (DA Style) Collets
Available 3/64" ~ 25/64"

Series 100 (DA Style) Collets
Available 3/64" ~ 9/16"

Series 180 (DA Style) Collets
Available 3/64" ~ 3/4"

Unit Nut Part No	Size	Type	Spanner No
RF 908100	M10x.75	ER-8M	RF 908160
RF 911120	M14x.75	UM/ER11	RF 911180
RF 920121	M25x1.5	UM/ER20	RF 920181
RF 925120	M32x1.5	UM/ER25	RF 925180
RF 932120	M40x1.5	UM/ER32	RF 932180
RF 940120	M50x1.5	UM/ER40	RF 940180

SUGINO GIVES YOU MORE CHOICES FOR AUTOMATING YOUR DRILLING AND TAPPING OPERATIONS



Global Electric Selffeeders

Choose from more than 30 models of cost-effective Global Selffeeders, power rated from 1/3 - 1.5 HP. Stroke lengths from 3.15" - 7.87". Coolant through the tool options available.

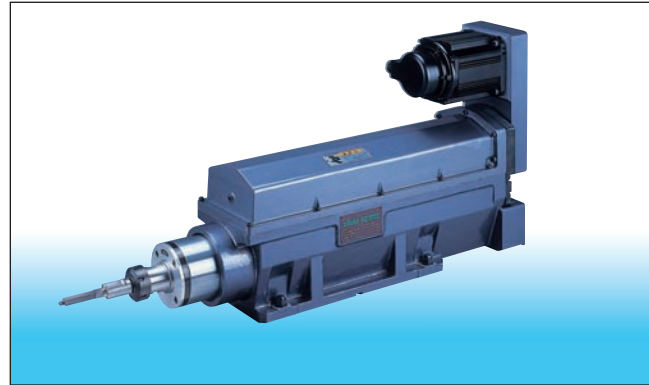

Varimec Servo Selffeeders

Varimec Servo Selffeeders provide strong and accurate ball-screw servo feed control drilling. Programmable and compact unit features ample power, stroke and thrust. An option to machining centers.

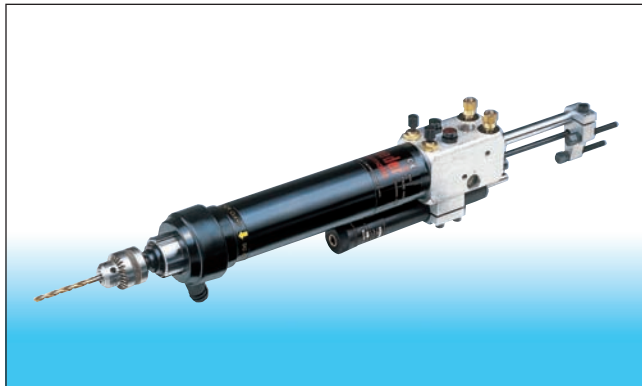

Pneumatic Selffeeders

Purely air-driven drilling units, Pneumatic Selffeeders offer tremendous versatility. Speeds range from 700 to 32,000 RPM. Economical machining for heavy and light industries. Efficient and precise at any angle.



Electric Ball-Screw Feed Synchro Tappers

These Tappers provide up to class 3 thread accuracy. Fast change pitch feed gears offer pitch feed ranges from 13 TPI to 113 TPI, without changing a lead-screw. Use independently or easily integrate into PLC-operated machines.



Sugino Corp.

1380 Hamilton Parkway, Itasca, IL 60143

Phone: (630) 250-8585 Fax: (630) 250-8665 TOLL FREE : 1-888-SUGINO 1
 website : www.suginocorp.com e-mail : mach@suginocorp.com

Japan Sugino Machine Limited Tokyo ☎+81-3-5201-5974 FAX +81-3-5201-5978
 e-mail: export@sugino.com

China Sugino Shanghai Co., Ltd
 Shanghai office ☎+86-21-5385-5031 FAX +86-21-5385-5032
 e-mail: sh@sugino.cn
 Guangzhou office ☎+86-20-8363-4719 FAX +86-20-8363-4992

Thailand Sugino Machine (Thailand) Ltd ☎+66-3572-9351 FAX +66-3572-9355
 e-mail: contact@sugino.th.com

Singapore Sugino Machine Singapore Pte. Ltd. ☎+65-6458-9544 FAX +65-6456-7789
 e-mail: sales@sugino-singapore.com.sg

*Specifications in this catalog are subject to change without prior notice for further improvement.

Copying or reprinting this catalog or its contents without expressed written permission from Sugino Corp. is prohibited.

This product and other related technology (include the program) are subject to the terms and conditions of the relevant foreign trade acts depending on end users and their applications

Catalog No. SFN-1210RA Copyright 2010, Sugino Corp. Printed in U.S.A.