

AUTOMATION
TECHNOLOGY

SPECIALTY CYLINDERS

BORES: 8 mm to 125 mm
R: ISO 6432 • ROV: OVAL BORE • SZ/SZV/NZK: COMPACT
AZ: ISO 6431 • AZV/RDV: TWIN ROD
DZB/DZBA/FSE: BLOCKING CYLINDERS
FEUG/FEHG/FEHK: LINEAR GUIDES

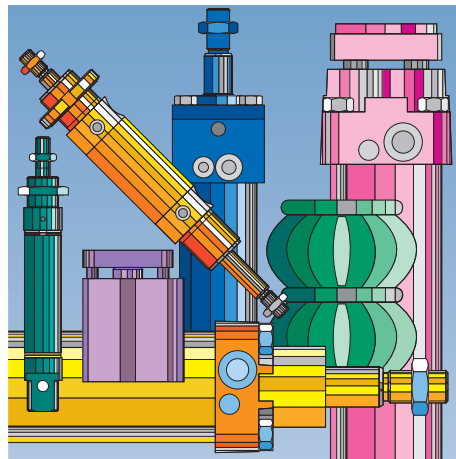

AZ Cylinder



Internal Construction

Parts reduction and design simplification have led to significant advantages in production and assembly operations - for a performance/price ratio which benefits the customer.

ISO 6431
VDMA 24562
CETOP RP43P

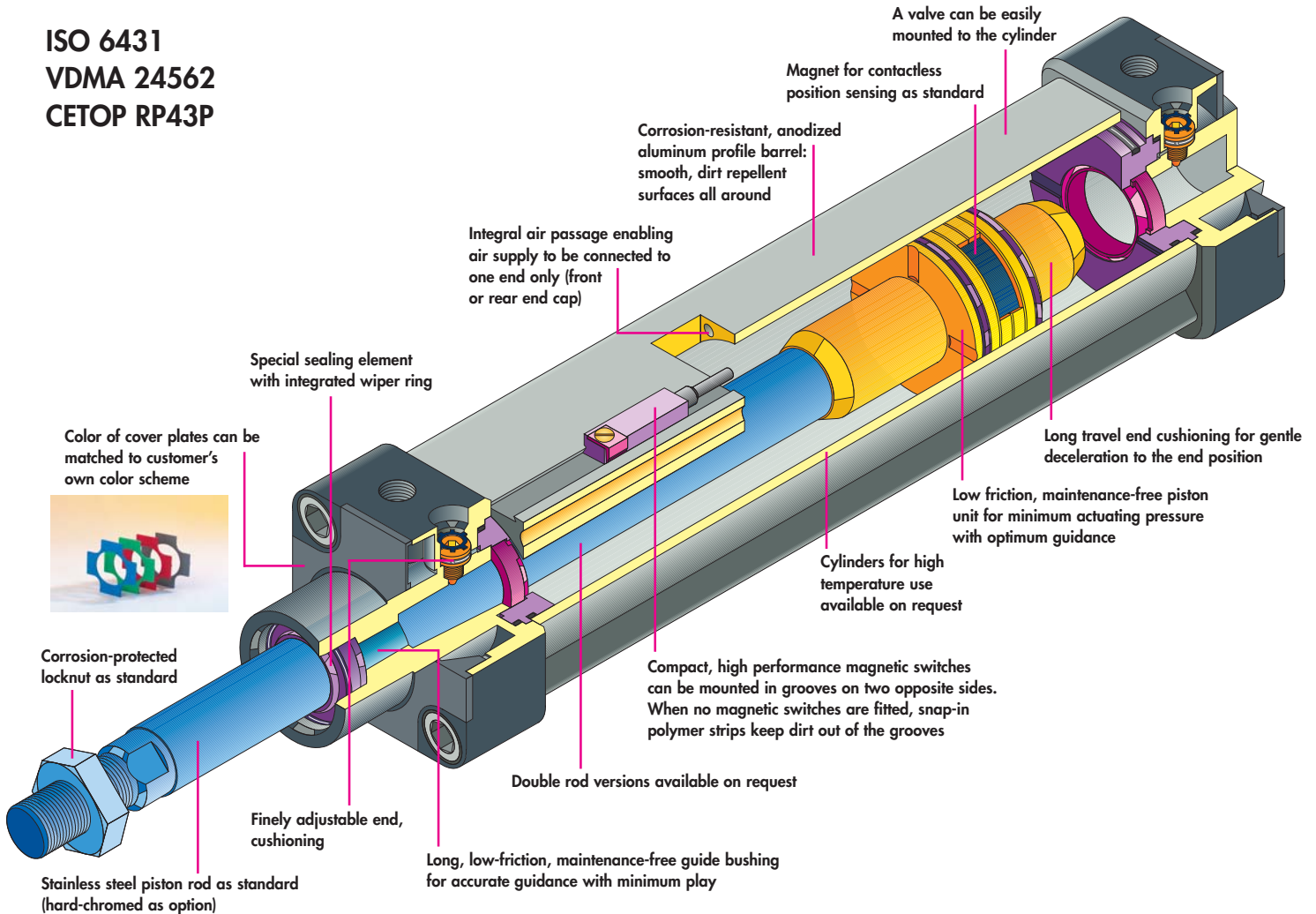

THE DESIGN

The first thing you'll notice about the AZ Series cylinder is its smooth profile and clean design. Structured to integrate into your system, it offers dirt repellent snap-in strips and end cap plates that can be matched to system colors.

A GROWING LINE TO HANDLE ALL YOUR NEEDS

Available in all popular diameters and strokes with double-acting and double-rod versions, as well as, compact and non-rotating models.

INTEGRAL AIR PASSAGE

The integral air passage enables the air supply to be connected to either conventional air connections or dual ports in the rear or front caps.

OPTIONS FOR SPECIAL APPLICATIONS

- Protective finish for added durability in hostile environments
- High temperature seals

DOVE-TAIL GROOVES

Two dove-tail grooves, on opposite sides of the cylinder barrel, allow easy fitting of small, high-performance magnetic switches (both reed and hall effect types), which are contained almost completely within the overall cylinder profile. In addition, the cylinder can be modified to accept a control valve mounted directly to it, forming one compact unit.

ESSENTIAL ACCESSORIES

Six different mounting options provide a wide range of installation options, even where space is tight.

$$I = \sum r^2 \varnothing m$$

Technical Section
Force and Load Charts
Pages 1-6

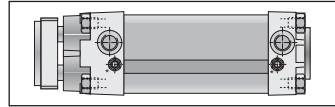

Series AZV
Twin Rod Cylinder
Bores 25mm-100mm
Pages 41-49

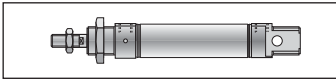

Series R
ISO 6432
Bores 10mm-25mm
Pages 7-11

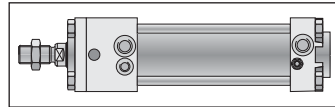

Series DZB
Blocking Cylinder
Bores 32mm-125mm
Pages 50-57

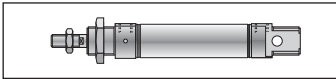

Series ROV
Oval Bore Cylinder
Bores 8mm-25mm
Pages 12-16

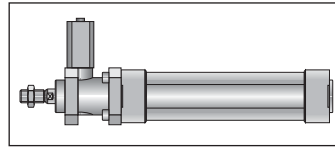

Series FSE
Blocking Cylinder
Bores 32mm-125mm
Pages 58-61

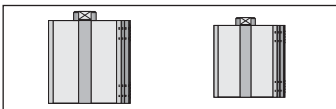

Series SZ
Compact Cylinder
Bores 12mm-100mm
Pages 17-21

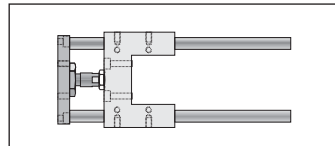

Series FEUG
Linear Guides
"U" Form
Bushing Type
ISO 6431 & 6432
Pages 62-66

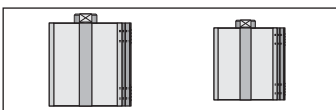

Series NZK
Compact Cylinder
Bores 32mm-100mm
Pages 22-24

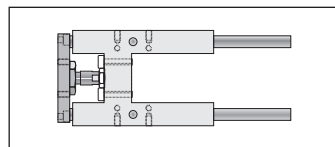

Series FEHG, FEHK'
Linear Guides
"H" Form
Bushing and Bearing Type
ISO 6431
Page 67-71

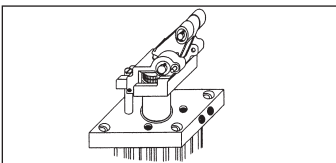

Series WST
Stopper Cylinder
Bores 50-80mm
Pages 25-28

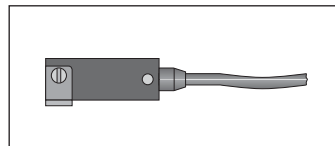

Sensors
Reed
Hall Effect (NPN, PNP)
Air
Welding Proof
Page 72-75

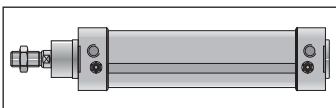

Series AZ
ISO 6431
Bores 32mm-100mm
Pages 29-36

Spares

Spare Parts
Seal Kits
Page 76-78



Series DZ
ISO 6431
Bores 125-250mm
Pages 37-40

General Information



Metric Conversions

(Multiply _____ By _____ to Convert to _____)

METRIC TO US

LENGTH

mm	0.0394	in
cm	0.3937	in
m	3.2808	ft

AREA

mm ²	0.0016	in ²
cm ²	0.1550	in ²

VOLUME

mm ³	6.10 x 10 ⁻⁵	in ³
cm ³ (cc)	0.0610	in ³
m ³	35.315	ft ³

WEIGHT

g	0.0353	oz
kg	2.2046	lb

FORCE

gF	2.205 x 10 ⁻³	lbf
N	0.2248	lbf

TORQUE

Nm	0.7376	ft•lb
----	--------	-------

PRESSURE

kPa	0.145	psi
Bar	14.50	psi
kg/cm ²	14.223	psi

TEMPERATURE

$$^{\circ}\text{F} = (1.8 \times \text{C}^{\circ}) + 32$$

FLOW RATE

$$\text{l/min} \times 0.035 = \text{SCFM}$$

$$\text{l/min} \div 1000 = \text{Cv}$$

US TO METRIC

LENGTH

in	25.4	mm
in	2.54	cm
ft	0.3048	m

AREA

in ²	645.16	mm ²
in ²	6.4516	cm ²

VOLUME

in ³	16387	mm ³
in ³	16.387	cm ³ (cc)
ft ³	0.0283	m ³

WEIGHT

oz	28.35	g
lb	0.4536	kg

FORCE

lbf	453.6	gf
lbf	4.4482	N

TORQUE

ft•lb	1.3559	Nm
-------	--------	----

PRESSURE

psi	6.895	kPa
psi	0.06895	Bar
psi	0.0703	kg/cm ²

TEMPERATURE

$$^{\circ}\text{C} = 5/9(^{\circ}\text{F} - 32)$$

FLOW RATE

$$\text{SCFM} \times 28.57 = \text{l/min}$$

$$\text{Cv} 1.0 = \text{Kv} 0.856$$

Technical Information



Force and Load Charts - All Cylinders (except ROV)

Piston Area	Bore													
	8	10	12	16	20	25	32	40	50	63	80	100	125	
A IN ²	0.078	0.122	0.175	0.311	0.487	0.761	1.246	1.947	3.043	4.831	7.791	12.174	19.021	
B IN ²	0.059	0.101	0.132	0.264	0.403	0.636	1.07	1.643	2.558	4.34	7.037	11.408	17.779	
Theoretical Forces lbf at ___ PSI														
PSI	15	1.17	1.83	2.63	4.67	7.31	11.42	18.69	29.21	45.65	72.47	116.87	182.61	285.32
	30	2.34	3.66	5.25	9.33	14.61	22.83	37.38	58.41	91.29	144.93	233.73	365.22	570.63
	45	3.51	5.49	7.88	14.00	21.92	34.25	56.07	87.62	136.94	217.40	350.60	547.83	855.95
	60	4.68	7.32	10.50	18.66	29.22	45.66	74.76	116.82	182.58	289.86	467.46	730.44	1141.26
	75	5.85	9.15	13.13	23.33	36.53	57.08	93.45	146.03	228.23	362.33	584.33	913.05	1426.58
	90	7.02	10.98	15.75	27.99	43.83	68.49	112.14	175.23	273.87	434.79	701.19	1095.66	1711.89
	105	8.19	12.81	18.38	32.66	51.14	79.91	130.83	204.44	319.52	507.26	818.06	1278.27	1997.21
	120	9.36	14.64	21.00	37.32	58.44	91.32	149.52	233.64	365.16	579.72	934.92	1460.88	2282.52
	135	10.53	16.47	23.63	41.99	65.75	102.74	168.21	262.85	410.81	652.19	1051.79	1643.49	2567.84
	150	11.70	18.30	26.25	46.65	73.05	114.15	186.90	292.05	456.45	724.65	1168.65	1826.10	2853.15

Piston Area	Bore													
	8	10	12	16	20	25	32	40	50	63	80	100	125	
A CM ²	0.502	0.785	1.131	2.01	3.141	4.91	8.04	12.56	19.63	31.17	50.26	78.54	122.7	
A CM ²	0.38	0.65	0.85	1.70	2.60	4.10	6.90	10.60	16.50	28.00	45.40	73.60	114.7	
Theoretical Forces kN at ___ bar														
BAR	1	0.005	0.007	0.01	0.018	0.028	0.044	0.072	0.112	0.175	0.279	0.450	0.703	1.099
	2	0.009	0.014	0.02	0.036	0.056	0.088	0.144	0.225	0.351	0.558	0.900	1.407	2.199
	3	0.014	0.021	0.03	0.054	0.084	0.131	0.216	0.337	0.527	0.837	1.351	2.111	3.298
	4	0.018	0.028	0.04	0.072	0.112	0.175	0.288	0.450	0.703	1.117	1.801	2.814	4.398
	5	0.023	0.035	0.05	0.090	0.140	0.219	0.360	0.563	0.879	1.396	2.251	3.518	5.497
	6	0.027	0.042	0.06	0.108	0.168	0.263	0.432	0.675	1.055	1.675	2.702	4.222	6.597
	7	0.032	0.049	0.07	0.126	0.197	0.307	0.504	0.788	1.231	1.955	3.152	4.926	7.696
	8	0.036	0.056	0.08	0.144	0.225	0.351	0.576	0.900	1.407	2.234	3.603	5.629	8.796
	9	0.041	0.063	0.09	0.162	0.253	0.395	0.648	1.013	1.583	2.513	4.053	6.333	9.896
	10	0.045	0.070	0.10	0.180	0.281	0.439	0.720	1.125	1.759	2.793	4.503	7.037	10.995



- A* = PUSH- Piston area
- B* = PULL- Piston area minus rod

The figures shown above relate to the piston area, PUSH. The forces for the piston area minus the rod are not shown in the chart shown above.

Technical Information



Force and Load Charts - ROV Oval Bore

Bore Ø	Piston Rod	Actuation		Theoretical Forces													
				Area in ²	lbf at __ PSI						Area cm ²	da N at __ Bar					
					30	45	60	75	90	105		2	3	4	5	6	7
8	4	Double Acting	A*	0.10	3.00	4.50	6.00	7.50	9.00	10.50	0.63	1.26	1.89	2.52	3.15	3.78	4.41
			B*	0.08	2.40	3.60	4.80	6.00	7.20	8.40	0.51	1.02	1.53	2.04	2.55	3.06	3.57
		Single Acting	A**	0.10	3.00	4.50	6.00	7.50	9.00	10.50	0.63	0.63	1.13	1.77	2.52	3.15	3.78
			B**	0.08	2.40	3.60	4.80	6.00	7.20	8.40	0.51	0.42	0.93	1.44	1.95	2.46	2.97
10	4	Double Acting	A*	0.16	4.80	7.20	9.60	12.00	14.40	16.80	1.00	2.00	3.00	4.00	5.00	6.00	7.00
			B*	0.14	4.20	6.30	8.40	10.50	12.60	14.70	0.88	1.76	2.64	3.52	4.40	5.28	6.16
		Single Acting	A**	0.16	4.80	7.20	9.60	12.00	14.40	16.80	1.00	1.25	2.37	3.63	4.12	5.00	6.12
			B**	0.14	4.20	6.30	8.40	10.50	12.60	14.70	0.88	0.91	1.79	2.67	3.55	4.43	5.31
12	6	Double Acting	A*	0.23	6.90	10.35	13.80	17.25	20.70	24.15	1.50	3.00	4.50	6.00	7.50	9.00	10.50
			B*	0.19	5.70	8.55	11.40	14.25	17.10	19.95	1.23	2.46	3.69	4.92	6.15	7.38	8.61
		Single Acting	A**	0.23	6.90	10.35	13.80	17.25	20.70	24.15	1.50	2.44	4.08	5.40	6.88	8.37	10.12
			B**	0.19	5.70	8.55	11.40	14.25	17.10	19.95	1.23	1.61	2.84	4.07	5.30	6.53	7.76
16	6	Double Acting	A*	0.31	9.30	13.95	18.60	23.25	27.90	32.55	2.00	4.00	6.00	8.00	10.00	12.00	14.00
			B*	0.28	8.40	12.60	16.80	21.00	25.20	29.40	1.83	3.46	5.20	6.90	8.70	10.40	12.10
		Single Acting	A**	0.31	9.30	13.95	18.60	23.25	27.90	32.55	2.00	3.50	5.00	7.40	8.20	9.10	12.00
			B**	0.27	8.10	12.15	16.20	20.25	24.30	28.35	1.73	1.51	3.25	4.95	6.75	8.45	10.15
20	8	Double Acting	A*	0.59	17.70	26.55	35.40	44.25	53.10	61.95	3.80	7.60	11.40	15.20	19.00	22.80	26.60
			B*	0.51	15.30	22.95	30.60	38.25	45.90	53.55	3.30	6.60	9.90	13.20	16.50	19.80	23.10
		Single Acting	A**	0.59	17.70	26.55	35.40	44.25	53.10	61.95	3.80	4.63	8.78	4.63	15.98	19.52	24.15
			B**	0.51	15.30	22.95	30.60	38.25	45.90	53.55	3.30	3.70	5.88	10.30	13.60	16.90	20.20
25	10	Double Acting	A*	0.67	20.10	30.15	40.20	50.25	60.30	70.35	4.30	8.60	12.90	17.20	21.50	25.80	30.10
			B*	0.55	16.50	24.75	33.00	41.25	49.50	57.75	3.52	7.04	10.56	14.08	17.60	21.12	24.64
		Single Acting	A**	0.67	20.10	30.15	40.20	50.25	60.30	70.35	4.30	6.40	11.70	16.20	21.50	26.30	31.20
			B**	0.55	16.50	24.75	33.00	41.25	49.50	57.75	3.52	4.14	7.66	11.18	14.70	18.22	21.74



- A* = PUSH- Piston Area
- B* = PULL- Piston Area minus Rod
- A** = PUSH- Piston Area
- B** = PULL- Piston Area minus Rod & Spring

Force and Load Charts - ROV Oval Bore

For correct cylinder selection at full rod extension, Force "F" should be below the load curve on the appropriate cylinder chart.

LATERAL LOAD OFFSET

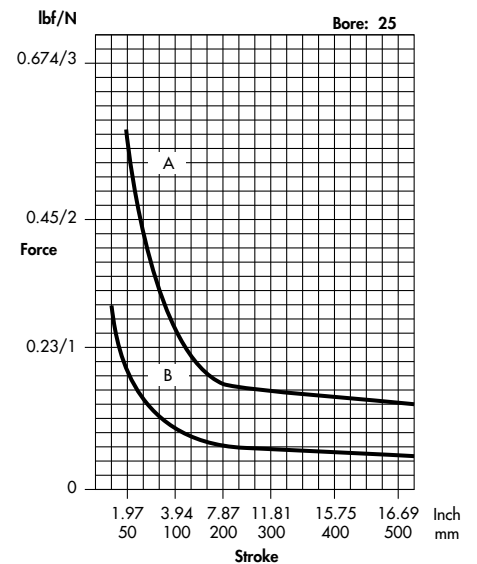
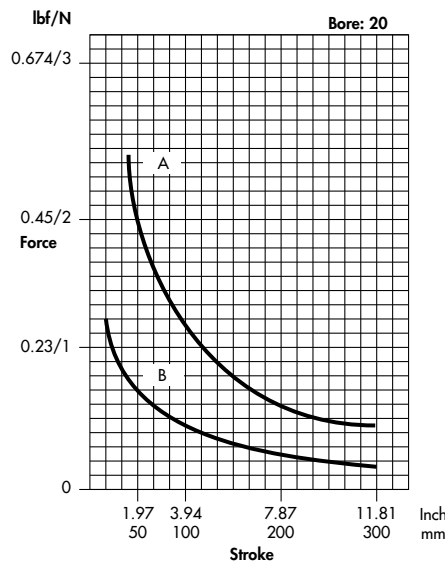
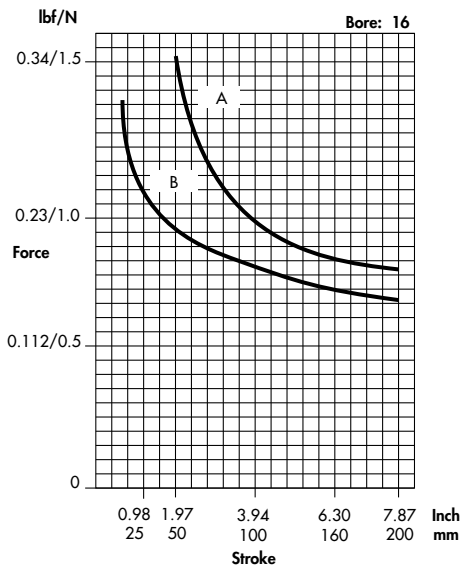
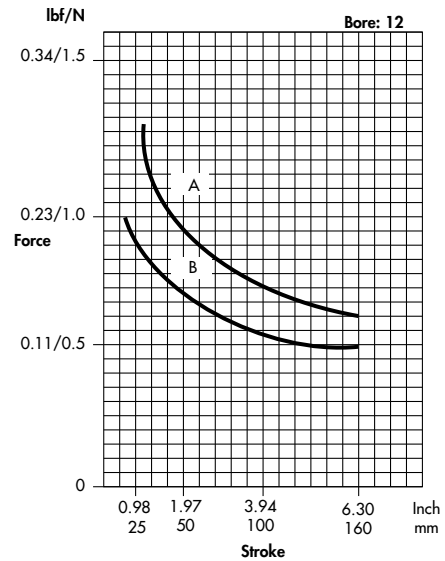
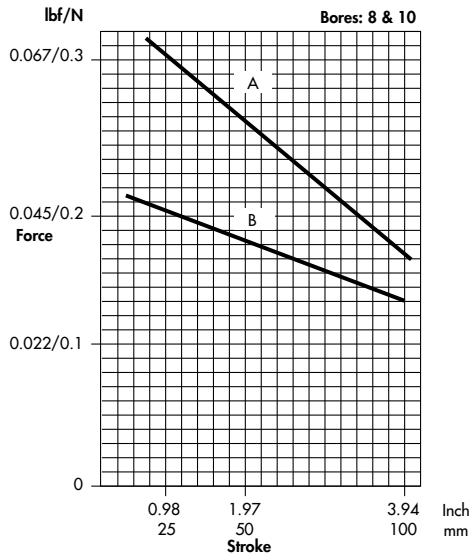
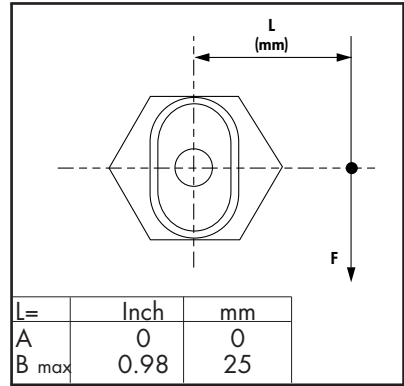

Technical Information



Force and Load Charts - AZV Twin Rod

Traverse Load Ø25-100mm

Torque Load Ø25-100mm

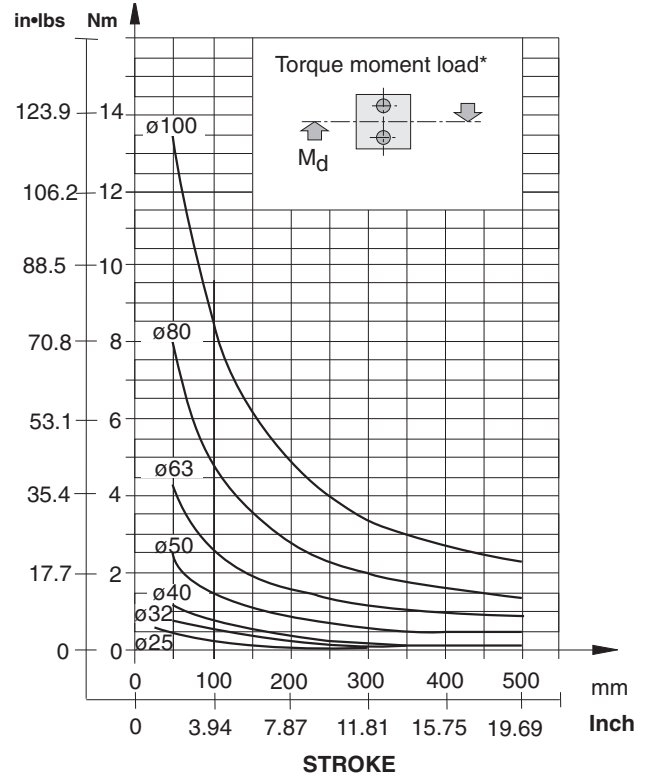
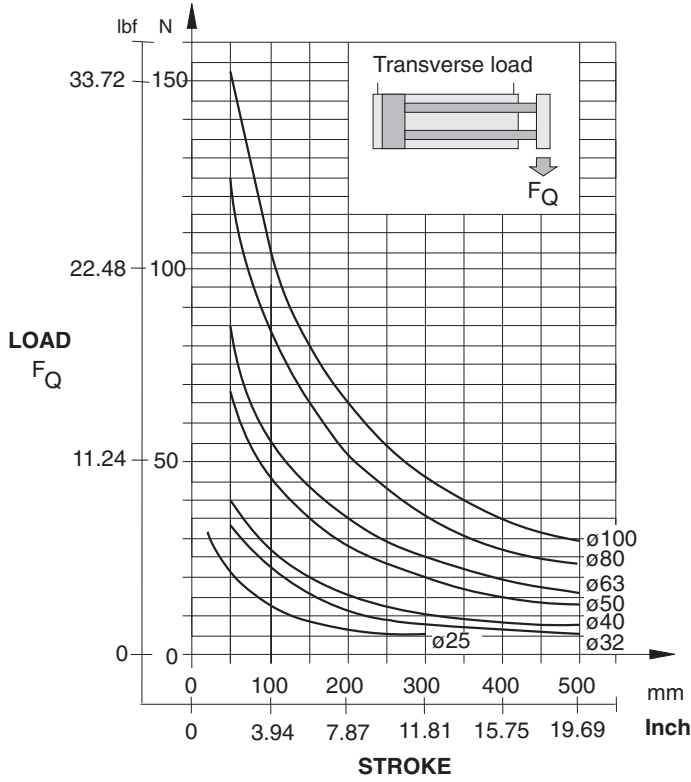

Side Load Ø25mm

Side Load Ø32mm

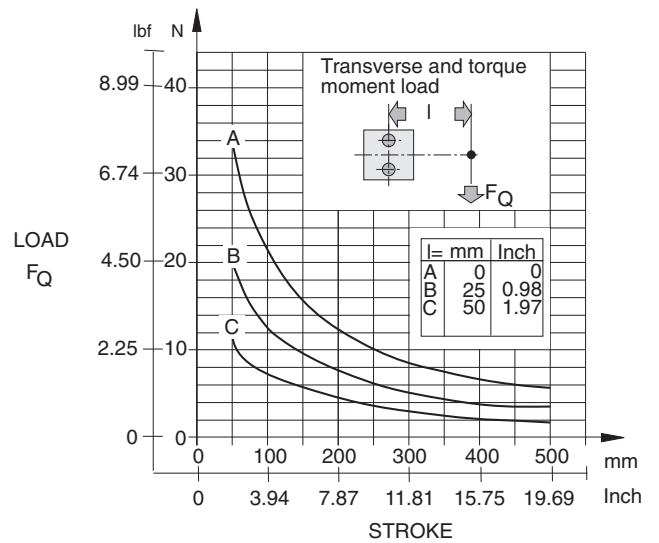
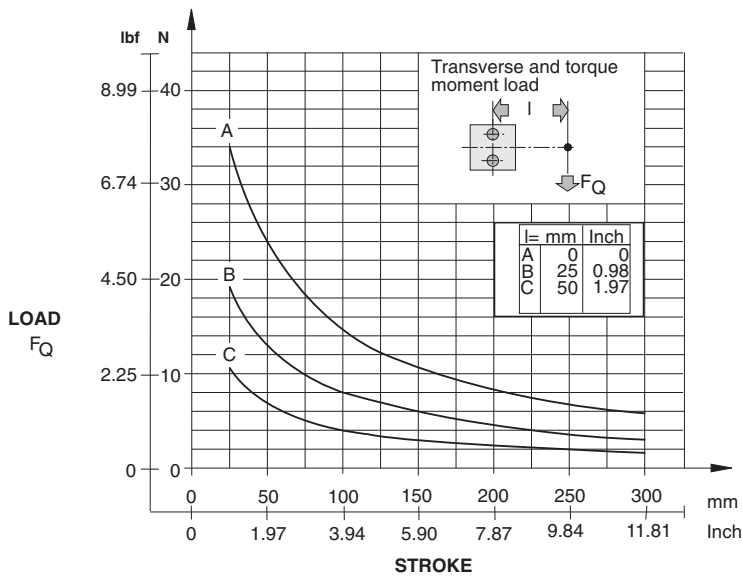

Technical Information



Force and Load Charts - AZV Twin Rod

Side Load Ø40mm

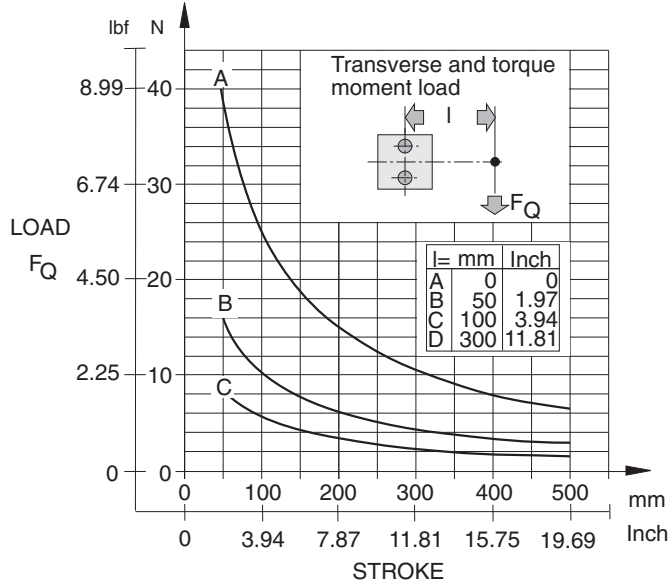

Side Load Ø50mm

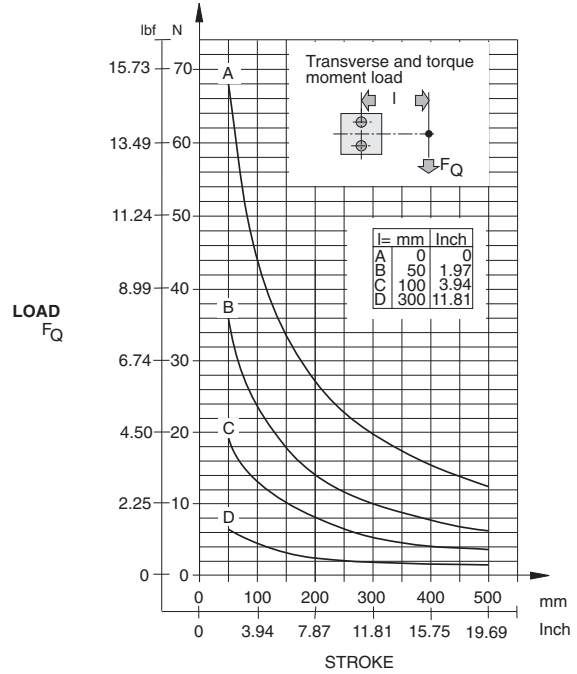

Side Load Ø63mm

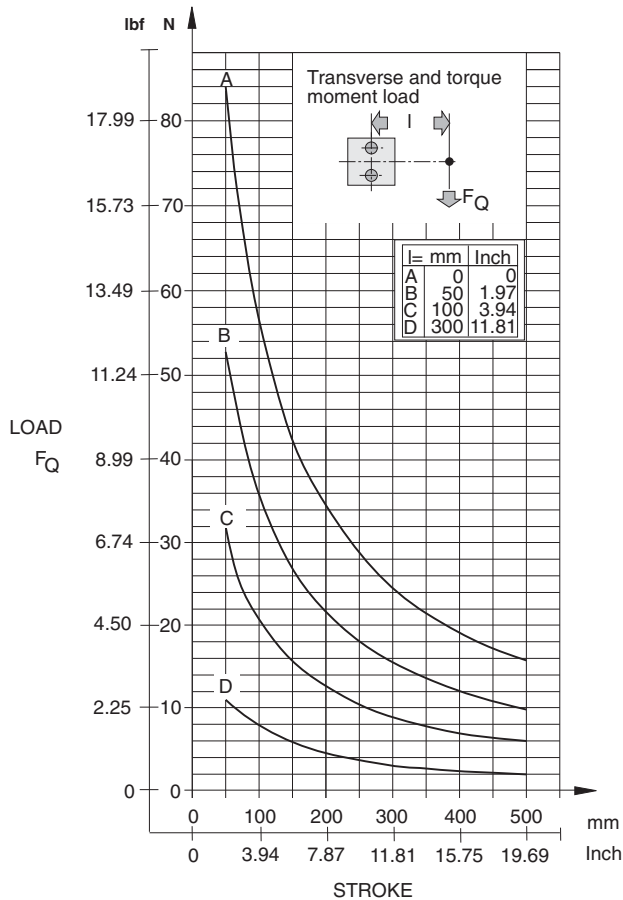

Side Load Ø80mm

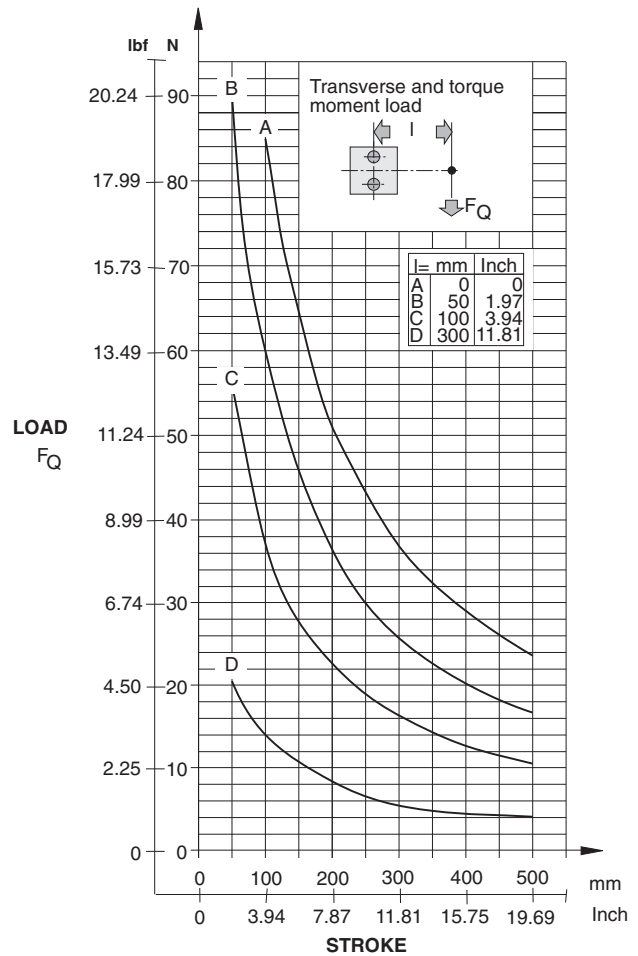

Technical Information



Force and Load Charts - AZV Twin Rod

Side Load Ø100mm

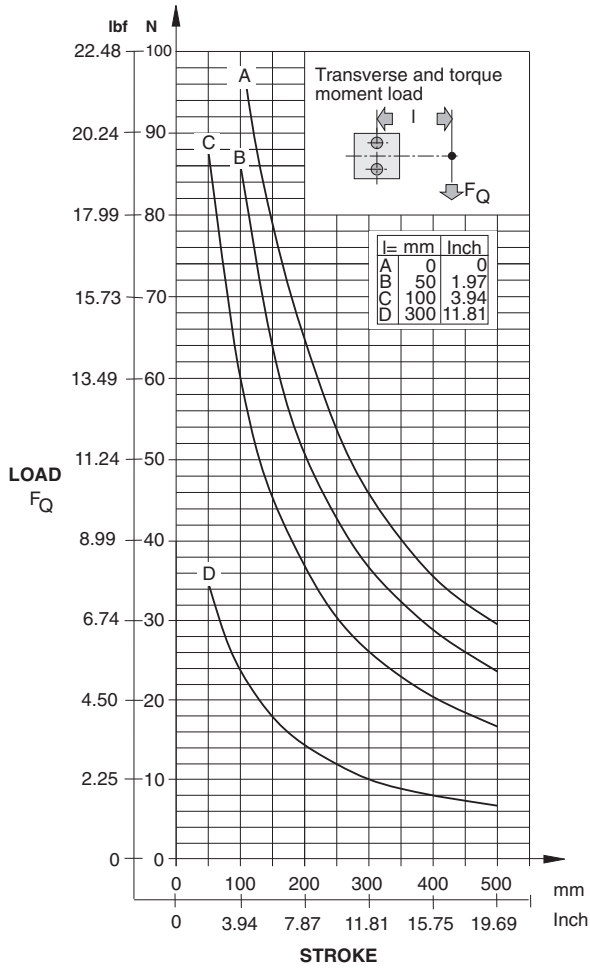

Recommended Installation

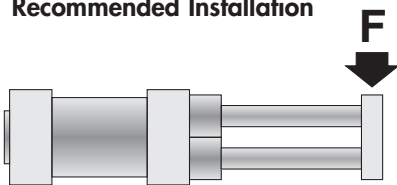

Cylinders should be mounted with the rods in the vertical orientation for optimum performance..

R Cylinder



Specifications

Features																											
Type	ISO 6432 CETOP RP52P																										
Series	R																										
Configurations	R2 Double Acting, Single Rod R3 Single Acting, Single Rod, Spring Return R5 Double Acting, Single Rod, Magnetic Piston, Cushions R6 Double Acting, Single Rod, Magnetic Piston RDU 6 Double Acting, Double Rod, Magnetic Piston																										
Construction Materials																											
Barrel	Stainless Steel																										
End Caps	Aluminum, Anodized (10µ)																										
Piston Rod	Stainless Steel																										
Characteristics																											
Operating Temperature	Min. -5° F (-20°C) Max. +176°F (+80°C)																										
Operating Pressure	<table border="0"> <tr> <td></td> <td>Ø10</td> <td>Ø12-25</td> <td colspan="4"></td> </tr> <tr> <td>Min:</td> <td>22 PSI (1.5 bar)</td> <td>15 PSI (1 bar)</td> <td colspan="4"></td> </tr> <tr> <td>Max:</td> <td>145 PSI (10 bar)</td> <td>145 PSI (10 bar)</td> <td colspan="4"></td> </tr> </table>							Ø10	Ø12-25					Min:	22 PSI (1.5 bar)	15 PSI (1 bar)					Max:	145 PSI (10 bar)	145 PSI (10 bar)				
	Ø10	Ø12-25																									
Min:	22 PSI (1.5 bar)	15 PSI (1 bar)																									
Max:	145 PSI (10 bar)	145 PSI (10 bar)																									
Normal Operating Pressure	90 PSI (6 bar)																										
Lubrication	Pre-lubricated at factory. If additional lubrication is required use oil compatible for NBR seal and designed for use in pneumatic systems.																										
Media	Filtered and regulated compressed air																										
Installation	In any position																										
Weight	See chart with mounts																										
Stroke Length	Up to 320mm - Longer contact factory																										
Theoretical Forces	See Technical Information Sheet																										
Load Capacity	See Technical Information Sheet																										
Specifications																											
Piston Diameter		10	12	16	20	25																					
Port Sizes	Metric (G)	M5	M5	M5	G1/8	G1/8																					
Rod Diameter	mm	4	6	6	8	10																					
Cushion Lengths	mm				17	17																					

Series R

Ø10mm - 25mm

ISO 6432

CETOP RP52P

R 2: Double Acting, Single Rod

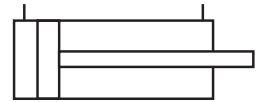

R 3: Single Acting, Single Rod

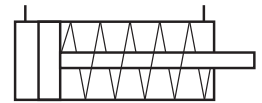

R 5: Double Acting, Single Rod, Magnets, Cushions

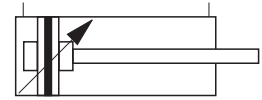

R 6: Double Acting, Single Rod, Magnets

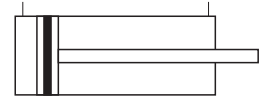

RDU 6: Double Acting, Double Rod, Magnets

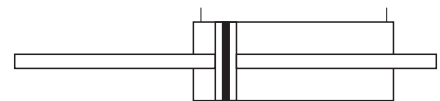

Features:

- Stainless Steel Rod
- Pre-Lubricated Design
- Magnetic Piston
- Adjustable Cushions

R Cylinder



Ordering Information

Example: R 5025/25
ISO 6432
Single Rod
Double Acting, Magnets, Cushions
25mm Bore
25mm Stroke

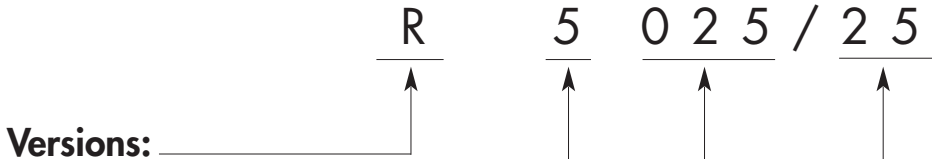

- R - Single Rod
- RDU - Double Rod

- Actuation:** _____
- 5 - Double Acting, Magnets, Cushions (Ø20 & 25)
 - 6 - Double Acting, Magnets
 - 2 - Double Acting
 - 3 - Single Acting, Magnets

Stroke:

- Ø10: any mm increment up to 100mm standard
- Ø12 & 16: any mm increment up to 160mm standard
- Ø20 & 25: any mm increment up to 320mm standard
- Contact factory for special stroke lengths
- Single acting stroke lengths of 10, 25 & 50mm

Bore:

- 010 - 10mm (nom. 7/16")
- 012 - 12mm (nom. 1/2")
- 016 - 16mm (nom. 3/4")
- 020 - 20mm (nom. 7/8")
- 025 - 25mm (nom. 1")

Proximity Sensors/Brackets: See Page 73

R Cylinder



Dimensional Data

R2, R3, R5, R6 Ø10-25mm

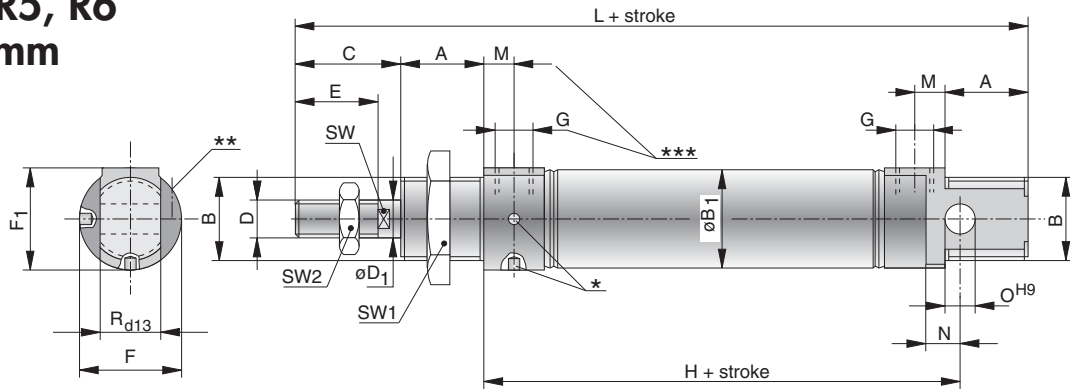

RDU 6 Ø12-25mm

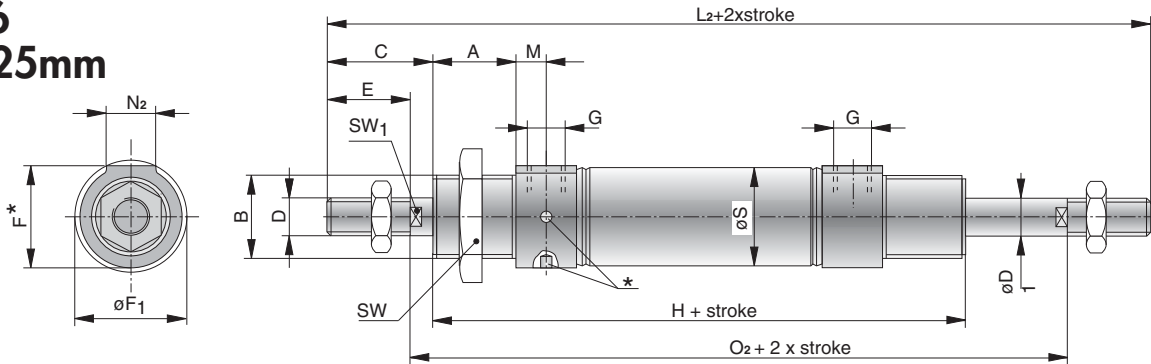

- * Holes for "C" Spanner Wrench
- ** Location of Adjustable Cushion, R5020 & R5025 Only
- *** Omit Dimensions "G" and "M" for Series R3 Cylinders

Bore Ø	A	B	B ₁	C	D	Ø D ₁	E	F	F ₁ hex	G	H + stroke	H ₂ + stroke
10	0.47 12	7/16 • 20 M12 x 1.25	0.44 11.3	0.63 16	6 • 32 M4	0.16 4	0.47 12	0.59 15	0.59 15	10 • 32 M5	1.89 48	- -
12	0.67 17	M16 x 1.5	0.52 13.3	0.83 21	M6	0.24 6	0.63 16	0.79 20	0.79 20	M5	2.09 53	3.23 82
16	0.67 17	5/8 • 18 M16 x 1.5	0.68 17.3	0.83 21	10 • 32 M6	0.24 6	0.63 16	0.79 20	0.79 20	10 • 32 M5	2.36 60	3.54 90
20	0.79 20	M22 x 1.5	0.83 21.3	0.94 24	M8	0.30 8	0.79 20	1.06 27	1.06 27	G1/8	2.80 71	4.25 108
25	0.87 22	7/8 • 14 M22 x 1.5	1.04 26.5	1.10 28	3/8 • 24 M10 x 1.25	0.39 10	0.87 22	1.06 27	1.06 27	1/8 NPTF G1/8	2.99 76	4.45 113
Bore Ø	L + stroke	L ₂ +2X stroke	M	N	N ₂	Ø O _{H9}	O ₂ +2X stroke	R _{d13}	ØS	SW	SW ₁	SW ₂
10	3.39 86		0.22 5.5	0.24 6	- -	0.16 4	- -	0.31 8	- -	0.12 3	0.67 17	- -
12	4.09 104	4.88 124	0.22 5.5	0.35 9	0.37 9.5	0.24 6	3.62 92	0.47 12	0.52 13.3	0.20 5	0.87 22	10
16	4.37 111	5.20 132	0.22 5.5	0.35 9	0.37 9.5	0.24 6	3.94 100	0.47 12	0.68 17.3	0.20 5	0.87 22	10
20	5.20 132	6.14 156	0.33 8.5	0.47 12	0.57 14.5	0.31 8	4.57 116	0.63 16	0.84 21.3	0.28 7	1.06 27	13
25	5.55 141	6.65 169	0.33 8.5	0.47 12	0.57 14.5	0.31 8	4.92 125	0.63 16	1.04 26.5	0.35 9	1.06 27	17

R Cylinder



Cylinder Mounts

Foot Mount- Type RA

- RA1- 1 Bracket with Mounting Nut
- RA2- 2 Brackets with Mounting Nuts

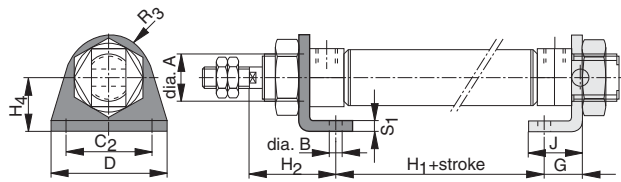

Rear Clevis- Type RB

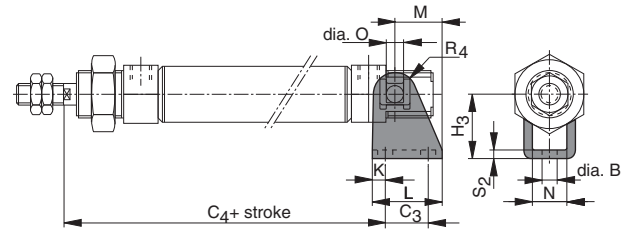

Front or Rear Flange- Type RC

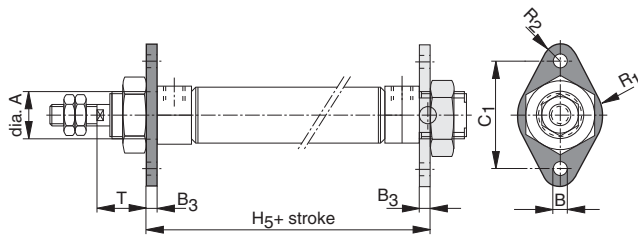

Ordering Information:
See ROV Series Cylinder on Page 14

Bore Ø	A	B	B ₃	C ₁	C ₂	C ₃	C ₄₊	D	G	H ₁ + stroke	H ₂	H ₃	H ₄	H ₅ stroke
10	0.47 12	0.18 4.5	0.12 3	1.18 30	0.98 25	0.49 12.5	2.56 65	1.38 35	0.43 11	1.14 29	0.94 24	0.94 24	0.63 16	2.52 64
12	0.63 16	0.22 5.5	0.16 4	1.57 40	1.26 32	0.59 15	2.87 73	1.65 42	0.55 14	1.02 26	1.26 32	1.06 27	0.79 20	2.83 72
16	0.63 16	0.22 5.5	0.16 4	1.57 40	1.26 32	0.59 15	3.15 80	1.65 42	0.55 14	1.30 33	1.26 32	1.06 27	0.79 20	3.11 79
20	0.87 22	0.26 6.6	0.20 5	1.97 50	1.57 40	0.79 20	3.58 91	2.13 54	0.67 17	1.69 43	1.42 36	1.18 30	0.98 25	2.83 97
25	0.87 22	0.26 6.6	0.20 5	1.97 50	1.57 40	0.79 20	3.94 100	2.13 54	0.67 17	1.89 48	1.57 40	1.18 30	0.98 25	4.13 105
Bore Ø	J	K	L	M	N	O	R ₁	R ₂	R ₃	R ₄	S ₁	S ₂	T	
10	0.63 16	0.26 6.5	0.91 23	0.71 18	0.32 8.1	0.16 4	0.49 12.5	0.20 5	0.39 10	0.20 5	0.12 3	0.10 2.5	0.51 13	
12	0.79 20	0.20 5	0.98 25	0.71 18	0.48 12.1	0.24 6	0.59 15	0.26 6.5	0.47 12	0.28 7	0.16 4	0.12 3	0.71 18	
16	0.79 20	0.20 5	0.98 25	0.71 18	0.48 12.1	0.24 6	0.59 15	0.26 6.5	0.47 12	0.28 7	0.16 4	0.12 3	0.71 18	
20	0.98 25	0.24 6	1.26 32	0.87 22	0.63 16.1	0.31 8	0.79 20	0.31 8	0.79 20	0.39 10	0.20 5	0.16 4	0.91 19	
25	0.98 25	0.24 6	1.26 32	0.87 22	0.63 16.1	0.31 8	0.79 20	0.31 8	0.79 20	0.39 10	0.20 5	0.16 4	0.91 23	

Proximity Sensors/Brackets: See Page 73

R Cylinder



Cylinder Accessories

Rod Clevis

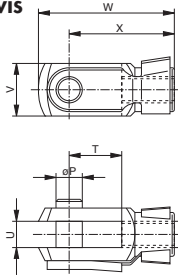

Order Instructions									
Order #	Bore Ø	ØP	T	U	V	W	X	Z	Weight (lbs.)(kg)
KZ 1413	8,10	0.16	0.31	0.16	0.31	0.87	0.63	M4	0.02
KY 6132	12,16	0.24	0.47	0.24	0.47	1.22	0.94	M6	0.04
KY 6133	20	0.31	0.63	0.31	0.63	1.65	1.26	M8	0.08
KY 6135	25	0.39	0.79	0.39	0.79	2.05	1.57	M10 x1.25	0.18

Rod Eye

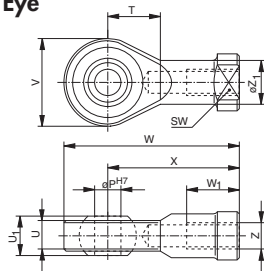

Order Instructions													
Order #	Bore Ø	Øp ^{H7}	T	U	U1	V	W	W ₁	X	Z	ØZ ₁	SW	Weight (lbs.)(kg)
KX 6023	8,10	0.20	0.35	0.24	0.31	0.63	1.38	0.47	1.06	0.35	0.31	0.05	
KY 6144	12,16	0.24	0.43	0.27	0.35	0.79	1.57	0.47	1.18	0.39	0.43	0.06	
KY 6145	20	0.31	0.51	0.35	0.47	0.94	1.89	0.63	1.42	0.49	0.55	0.09	
KY 6147	25	0.39	0.59	0.41	0.55	1.10	2.24	0.79	1.69	0.59	0.67	0.16	

Rod Alignment Coupling

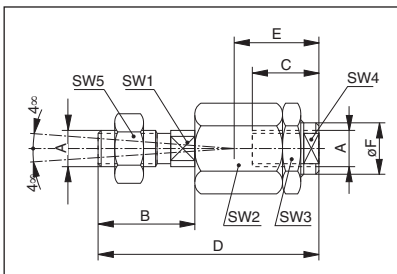

Angular Compensation

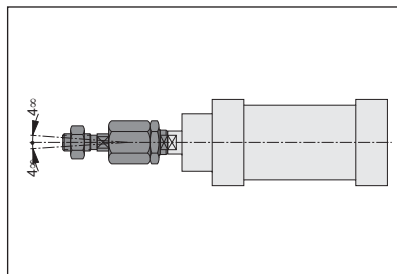

Radial Compensation for the Center Axis

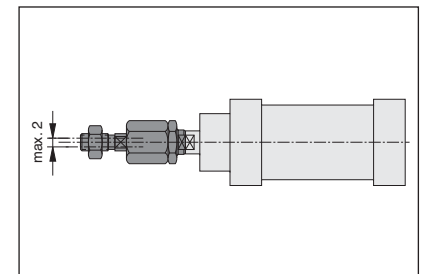

Order Instructions													
Order #	Bore Ø	A	B	C	D	E	ØF	SW ₁	SW ₂	SW ₃	SW ₄	SW ₅	Weight (lbs.)(kg)
KY 1152	8,10	M4	0.31	0.55	1.34	0.79	0.47	0.12	0.47	0.47	0.47	0.28	0.04
KY 1126	12,16	M6	0.47	0.43	1.42	0.55	0.33	0.20	0.51	0.51	0.28	0.39	0.05
KY 1127	20	M8	0.51	0.55	1.81	0.79	0.49	0.28	0.67	0.67	0.39	0.51	0.11
KY 1129	25	M10x1.25	0.79	0.91	2.76	1.22	0.85	0.47	1.18	1.18	0.75	0.67	0.48

Proximity Sensors/Brackets: See Page 73

ROV Oval Bore Cylinder



Specifications

Features	
Type	Oval Bore (ISO 6432)
Series	ROV
Configurations	ROV 6 Double Acting, Single Rod, Magnetic Piston ROV 7 Single Acting, Single Rod, Magnetic Piston, Spring Return ROVD 6 Double Acting, Double Rod, Magnetic Piston ROVDG Double Acting, Double Rod, Magnetic Piston, Hollow Rod
Construction Materials	
Barrel	Stainless Steel
End Caps	Aluminum, Anodized (10µ)
Piston Rod	Stainless Steel
Rod Bearing	Teflon Impregnated Bronze
Piston	Urethane
Seals	Urethane
Cushion Needle	Brass
Characteristics	
Operating Temperature	Min. 14° F (-10°C) Max. +176°F (+70°C)
Operating Pressure	Min. Double Acting - 15 PSI (1 bar), Single Acting - 30 PSI (2 bar) Max. 145 PSI (10 bar)
Normal Operating Pressure	90 PSI (6 bar)
Lubrication	Pre-lubricated at factory. If additional lubrication is required use oil compatible with NBR seals and designed for use in pneumatic systems.
Media	Filtered and Regulated Compressed Air
Installation	In any Position
Weight	See Chart - Page 15
Stroke Length	Varies by Bore Size
Theoretical Forces	See Technical Information Sheet
Load Capacity	See Technical Information Sheet
Specifications	
Piston Diameter	8 10 12 16 20 25
Port Sizes	Metric (G) M5 M5 M5 M5 G 1/8 G 1/8
Rod Diameter	mm 4 4 6 6 8 10
Cushion Lengths	mm -- -- -- -- 14 16

Series ROV

Ø8mm - 25mm

Oval Bore (ISO 6432)

ROV 6: Double Acting, Single Rod, Magnets

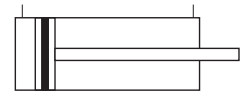

ROV 7: Single Acting, Single Rod, Magnets

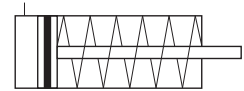

ROVD 6: Double Acting, Double Rod, Magnets

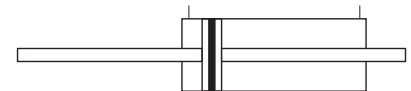

ROVDG: Double Acting, Double Rod, Magnets, Hollow Rod

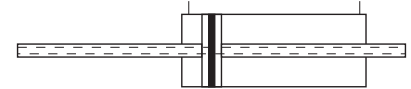

Features:

- Stainless Steel Rod
- Pre-Lubricated Design
- Magnetic Piston
- Adjustable Cushions (Ø20 & 25 only)
- Double Hollow Rod

ROV Oval Bore Cylinder



Ordering Information

Example: ROV 6020/50
Oval Piston
Single Rod
Double Acting, Magnets
20mm Bore
50mm Stroke

ROV 6 0 2 0 / 5 0

Versions:

- ROV - Single Rod
- ROVD - Double Rod
- ROVDG - Double Hollow Rod

Actuation:

- 5 - Double Acting, Magnets, Cushions
- 6 - Double Acting, Magnets
- 7 - Single Acting, Magnets

Proximity Sensors/Brackets: See Page 73

Stroke:

- MM: (standard)
- Ø8 & 10: any mm increment up to 100mm standard
 - Ø12 & 16: any mm increment up to 300mm standard
 - Ø20 & 25: any mm increment up to 500mm standard
 - Contact factory for special stroke lengths
 - Single acting stroke lengths of 10, 25 & 50mm

Bore:

- 008 - 8mm (nom. 5/16")
- 010 - 10mm (nom. 7/16")
- 012 - 12mm (nom. 1/2")
- 016 - 16mm (nom. 3/4")
- 020 - 20mm (nom. 7/8")
- 025 - 25mm (nom. 1")

ROV Oval Bore Cylinder



Cylinder Mounts

Weights		8mm		10mm		Bore Ø 12mm		16mm		20mm		25mm	
		*1	*2	1	2	1	2	1	2	1	2	1	2
Basic Cylinder	lbs.	.178		.198	.088	0.33	.132	.374	.176	.847	.286	.847	.286
	kg	0.081		0.090	0.040	0.150	0.060	0.170	0.080	0.385	0.130	0.385	0.130
Type RA (1 bracket)	lbs.	.048		.048		.095		.095		0.22		0.22	
	kg	0.022		0.022		0.043		0.043		0.100		0.100	
Type RC	lbs.	.029		.029		.062		.062		0.11		0.11	
	kg	0.013		0.013		0.028		0.028		0.050		0.050	
Type RB	lbs.	.051		.051		.079		.079		.176		.176	
	kg	0.023		0.023		0.036		0.036		0.080		0.080	

*1 = Weight for cylinder with (100 mm) stroke

*2 = Weight for every additional (100 mm) stroke length

Body Mounts		8mm	10mm	Bore Ø 12mm	16mm	20mm	25mm
Foot Mount (single pc.)							
Type: RA1-	Metric	KX 9271	KX 9271	KK 26.302	KK 26.302	KK 28.302	KK 28.302
Foot Mount (Set)							
Type: RA2-	Metric	PD 31522	PD 31522	PD 25771	PD 25771	PD 25772	PD 25772
Rear Clevis							
Type: RB-	Metric	KZ 1412	KZ 1412	KZ 1419	KZ 1419	KZ 1420	KZ 1420
Front or Rear Flange							
Type: RC	Metric	KX 9272	KX 9272	KK 26.305	KK 26.305	KK 28.305	KK 28.305

Dimensional Information: See R Series Cylinder on Page 10.

Rod Accessories		8mm	10mm	Bore Ø 12mm	16mm	20mm	25mm
Rod Nut	Metric	ZP 3838	ZP 3838	ZP 1730	ZP 1730	ZP 2128	ZP 1810
Nose Nut	Metric	ZP 4077	ZP 4077	ZP 4078	ZP 4078	PD 35855	PD 35855
Rod Clevis	Metric	KZ 1413	KZ 1413	KY 6132	KY 6132	KY 6133	KY 6135
Rod Eye	Metric	KX 6023	KX 6023	KY 6144	KY 6144	KY 6145	KY 6147
Rod Alignment Coupling	Metric	KY 1152	KY 1152	KY 1126	KY 1126	KY 1127	KY 1129

Dimensional Information: See R Series Cylinder on Page 11

Proximity Sensors/Brackets: See Page 73

ROV Oval Bore Cylinder



Dimensional Data

ROV Ø8-25mm

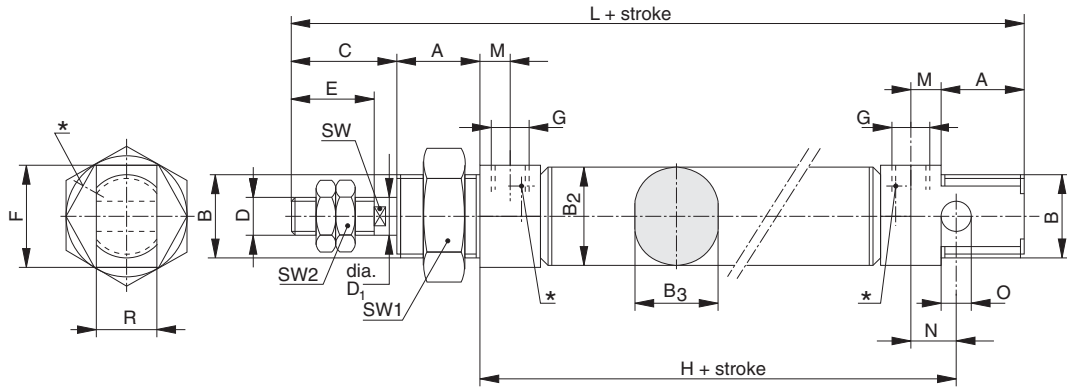

- * Port is omitted on the Spring Return version
- ** Adjustable Cushion Location. Bore 20 and 25 ONLY

ROVD Ø8-25mm

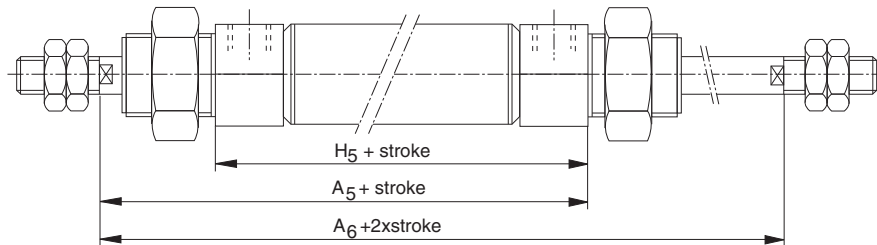

See ROV drawing for balance of dimensions

ROVDG Ø8-25mm

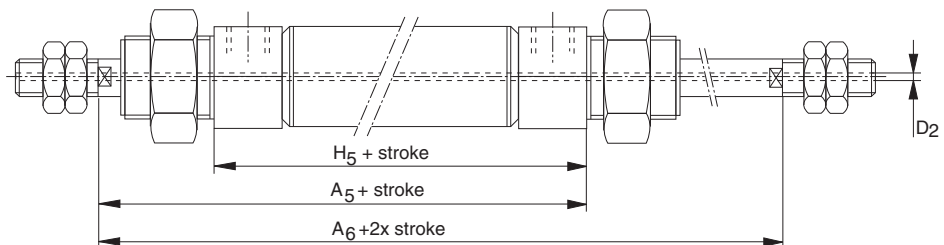

See ROV and ROVD drawings for balance of dimensions

ROV Oval Bore Cylinder



Dimensional Data

Bore Ø	A	A ₅ + stroke	A ₆ +2 x stroke	B	B ₂	B ₃	C	D	Ø D ₁	D ₂	E	F hex
8	0.51 13	2.40 61	3.03 77	M12 x 1.25	0.56 11.8	0.33 8.3	0.59 15	M4	0.16 4	0.04 1	0.47 12	14
10	0.51 13	2.40 61	3.03 77	7/16 • 20 M12 x 1.25	0.56 14.3	0.41 10.3	0.59 15	6 • 32 M4	0.16 4	0.04 1	0.47 12	0.55 14
12	0.67 17	2.68 68	3.54 90	M16 x 1.5	0.68 17.3	0.48 12.3	0.83 21	M6	0.24 6	0.05 1.2	0.63 16	0.79 20
16	0.67 17	2.95 75	3.82 97	5/8 • 18 M16 x 1.5	0.78 19.8	0.56 14.3	0.83 21	10 • 32 M6	0.24 6	0.05 1.2	0.63 16	0.79 20
20	0.79 20	3.58 91	4.53 115	M22 x 1.5	1.00 25.5	0.81 20.5	0.94 24	M8	0.30 8	0.13 3.2	0.79 20	1.06 27
25	0.87 22	3.94 100	5.04 128	7/8 • 14 M22 x 1.5	1.04 26.5	0.89 22.5	1.10 28	3/8 • 24 M10 x 1.25	0.39 10	0.13 3.2	0.87 22	1.06 27
Bore Ø	G	H + stroke	H ₅ + stroke	L + stroke	M	N	O _{H9}	R _{d13}	SW	SW1	SW2	
8	M5	1.89 48	1.77 45	3.39 86	0.24 6	0.24 6	0.16 4	0.30 8	--	19	7	
10	10 • 32 M5	1.89 48	1.77 45	3.39 86	0.24 6	0.24 6	0.16 4	0.3 8	--	19	7	
12	M5	2.09 53	1.81 46	4.21 102	0.24 6	0.35 9	0.24 6	0.47 12	5	23	10	
16	10 • 32 M5	2.36 60	2.09 53	4.21 107	0.24 6	0.35 9	0.24 6	0.47 12	5	23	10	
20	G1/8	2.80 71	2.64 67	5.20 132	0.30 8	0.47 12	0.31 8	0.63 16	7	32	13	
25	1/8 NPTF G1/8	2.99 76	2.83 72	5.63 143	0.31 8	0.47 12	0.31 8	0.63 16	9	32	17	

SZ Compact Cylinder



Specifications

Features	
Type	Compact Cylinder
Series	SZ
Configurations	SZ6 Double Acting, Single Rod, Magnetic Piston SZD6 Double Acting, Double Rod, Magnetic Piston SZV6 Double Acting, Non-Rotating, Magnetic Piston SZ7 Single Acting, Single Rod, Magnetic Piston, Spring Return
Construction Materials	
Barrel	Extruded Aluminum, Anodized (10µ)
Front Cover	Brass: Ø 12 to 40 Aluminum: Ø 50 to 100
Rear Cover	Aluminum, Anodized (10µ)
Piston Rod	Stainless Steel
Rod Bearing	Teflon Impregnated Brass
Piston	Delron: Ø 12 to 40 Aluminum: Ø 50 to 100
Seals	NBR (Optional: Viton)
Guide Rods	Stainless Steel
Guide Rod Bearings	Teflon Impregnated Steel
Tooling Plate	Aluminum, Anodized (10µ)
Bumpers	Polyurethane
Characteristics	
Operating Temperature	14° F (-10°C) to 158 °F (+70°C)
Operating Pressure	Min. SZ 6/SZV6 15 PSI (1 bar) SZD ø12 38 PSI (2.5 bar) ø16, 20 30 PSI (2 bar) ø25-40 22 PSI (1.5 bar) ø50-100 15 PSI (1 bar) Max. 145 PSI (10 bar)
Normal Operating Pressure	90 PSI (6 bar)
Lubrication	Pre-lubricated at factory. If additional lubrication is required, use oil compatible with NBR seals and designed for use in pneumatic systems.
Media	Filtered and Regulated Compressed Air
Installation	In any Position
Weight	See Chart - Page 19
Stroke Length	Varies by Bore Size
Theoretical Forces	See Technical Information Sheet
Load Capacity	See Technical Information Sheet
Specifications	
Piston Diameter	12 16 20 25 32 40 50 63 80 100
Port Sizes	NPT 10•32 10•32 10•32 1/8 1/8 1/8 1/8 1/8 1/8 1/4 1/4 Metric (G) M5 M5 M5 1/8 1/8 1/8 1/8 1/8 1/8 1/4 1/4
Rod Diameter	Inch 0.24 0.31 0.39 0.47 0.47 0.63 0.78 0.78 0.78 0.98 1.26 mm 6 8 10 12 12 20 20 20 20 25 32

Series SZ

Ø12mm - 100mm

SZ 6: Double Acting, Single Rod, Magnets

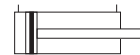

SZD 6: Double Acting, Double Rod, Magnets

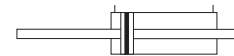

SZV 6: Double Acting, Non-Rotating, Magnets



SZ 7: Single Acting, Single Rod, Magnets

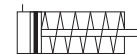

Features:

- Stainless Steel Rod
- Magnetic Piston
- Bumpers
- Pre-Lubricated Design
- Inch or Metric Construction

SZ Compact Cylinder



Ordering Information

Example: SZV-U 6050/50-D
 Compact Cylinder
 Non-Rotating
 U.S. Option
 Double Acting, Magnets
 50mm Bore
 50mm Stroke
 Threaded Body Option

S Z V - U 6 0 5 0 / 5 0 - D

Versions:

- SZ - Single Rod
- SZD - Double Rod
- SZV - Non-Rotating

Design:

- - Metric Construction
- U - US Construction: NPT Ports & UNC Threads

Actuation:

- 6 - Double Acting, Magnets
- 7 - Single Acting, Magnets

Options:

- - Standard
- D - Threaded Body, top & bottom

Stroke:

- MM: (standard)
- any mm increment
 - see stroke length chart on next page for maximum stroke lengths
 - contact factory for special stroke lengths

Bore:

- 012 - 12mm (nom. 1/2")
- 016 - 16mm (nom. 3/4")
- 020 - 20mm (nom. 7/8")
- 025 - 25mm (nom. 1")
- 032 - 32mm (nom. 1-1/4")
- 040 - 40mm (nom. 1-1/2")
- 050 - 50mm (nom. 2")
- 063 - 63mm (nom. 2-1/2")
- 080 - 80mm (nom. 3-1/8")
- 100 - 100mm (nom. 4")

Proximity Sensors/Brackets: See Page 73

SZ Compact Cylinder



Cylinder Details

Standard Strokes (MM)	Bore Ø									
	12mm	16mm	20mm	25mm	32mm	40mm	50mm	63mm	80mm	100mm
SZ-U 6	Double Acting, Single Rod									
SZD-U 6	Double Acting, Double Rod									
5	•	•	•	•	•	•	•	•	•	•
10	•	•	•	•	•	•	•	•	•	•
15	•	•	•	•	•	•	•	•	•	•
20	•	•	•	•	•	•	•	•	•	•
25	•	•	•	•	•	•	•	•	•	•
30			•	•	•	•	•	•	•	•
40			•	•	•	•	•	•	•	•
50			•	•	•	•	•	•	•	•
60				•	•	•	•	•	•	•
80					•	•	•	•	•	•
SZV-U 6	Double Acting, Non-Rotating									
5			•	•	•	•	•	•		
10			•	•	•	•	•	•		
15			•	•	•	•	•	•		
20			•	•	•	•	•	•		
25			•	•	•	•	•	•		
30			•	•	•	•	•	•		
40			•	•	•	•	•	•		
50			•	•	•	•	•	•		
60				•	•	•	•	•		
80					•	•	•	•		
SZ-U 7	Single Acting, Single Rod									
5	•	•	•	•	•	•				
10	•	•	•	•	•	•				
25		•	•	•	•	•				

(Contact the factory for non-standard stroke lengths)

Spring Forces

Mode		Bore Ø									
		12mm	16mm	20mm	25mm	32mm	40mm	50mm	63mm	80mm	100mm
Cylinder Extended	lbf	2.25	4.05	6.07	6.97	10.57	13.04	19.33	23.60	29.23	33.72
	N	10	18	27	31	47	58	86	105	130	150
Retracted Stroke (5mm)	lbf	1.80	3.37	5.17	5.85	8.54	10.79	--	--	--	--
	N	8	15	23	26	38	48	--	--	--	--
Retracted Stroke (10mm)	lbf	1.35	2.70	4.27	4.72	6.29	8.54	15.74	20.23	25.63	31.02
	N	6	12	19	21	28	38	70	90	114	138
Spring Constant	lbf/in	2.23	3.08	4.05	5.14	10.34	11.71	--	--	--	--
	N/mm	0.39	0.54	0.71	0.9	1.81	2.05	--	--	--	--
Retracted Stroke (25mm)	lbf	--	2.47	4.27	4.50	6.29	8.54	10.79	15.06	20.23	26.98
	N	--	11	19	20	28	38	48	67	90	120
Spring Constant	lbf/in	--	1.54	2.00	2.57	4.28	4.57	8.62	8.79	9.25	12.33
	N/mm	--	0.27	0.35	0.45	0.75	0.8	1.51	1.54	1.62	2.16

Weights

Cylinder Type		Bore Ø									
		12mm	16mm	20mm	25mm	32mm	40mm	50mm	63mm	80mm	100mm
SZ 6/7 per 0.38"(10mm)	lbs	0.11	0.18	0.24	0.35	0.51	0.77	1.10	1.98	2.87	4.63
	kg	0.05	0.08	0.11	0.16	0.23	0.35	0.50	0.90	1.30	2.10
	lbs	0.03	0.04	0.05	0.07	0.09	0.13	0.18	0.24	0.30	0.47
SZD 6 per 0.38"(10mm)	kg	0.013	0.018	0.022	0.033	0.042	0.059	0.080	0.108	0.138	0.213
	lbs	0.13	0.22	0.31	0.44	0.62	0.95	1.43	2.34	3.44	5.60
	kg	0.06	0.10	0.14	0.20	0.28	0.43	0.64	1.06	1.56	2.54
SZV 6 per 0.38"(10mm)	lbs			0.05	0.08	0.10	0.14	0.20	0.25		
	kg			0.022	0.036	0.046	0.065	0.090	0.115		
	lbs			0.49	0.62	0.77	1.06	1.41	2.65		
kg			0.22	0.28	0.35	0.48	0.65	1.20			

SZ Compact Cylinder



Dimensional Data

SZ6 and SZ7 Ø12-100mm

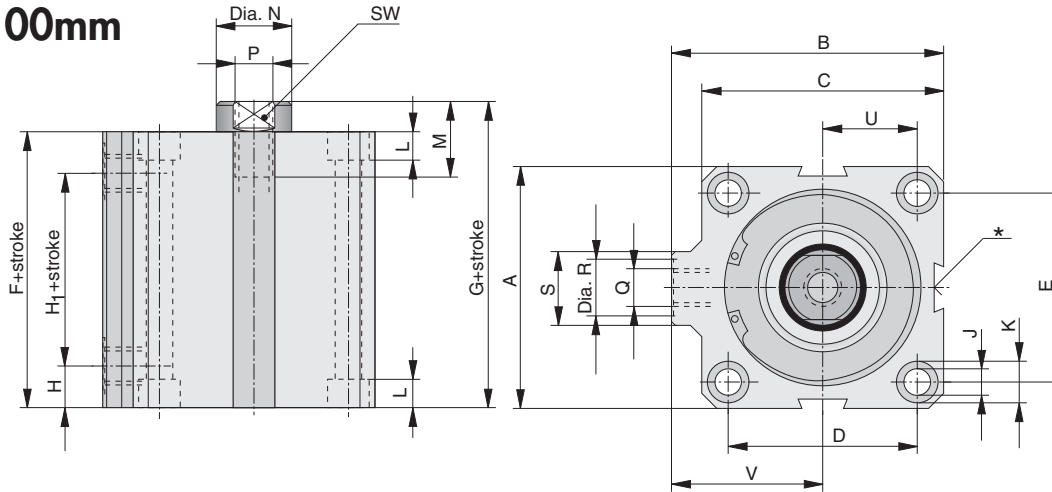

SZD 6 Ø12-100mm

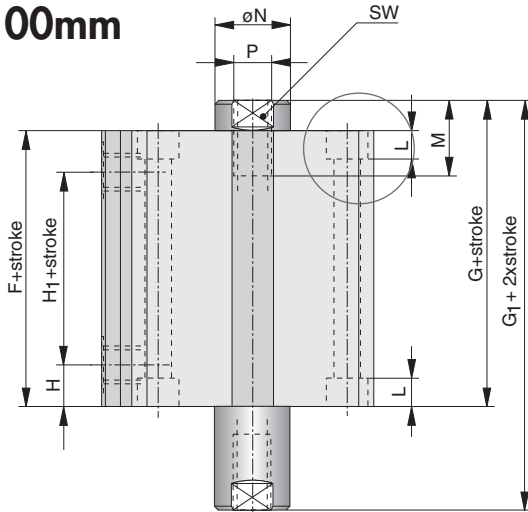

Threaded Mounting Holes: OPTION- D

In addition to the counter bored thru-holes, threaded mounting holes are available. The diagram below details this feature.

of threaded hole: SZV: (2) Bottom Only
SZ6/7 & SZD 6: (8) Bottom & Top

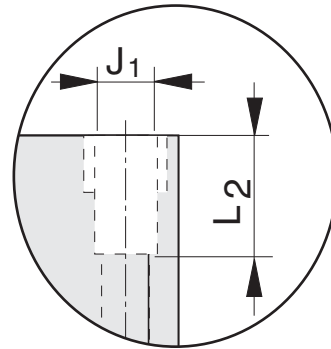

Dimension Explanations:

- J- Hole diameter thru Extrusion
- K- Counter Bore Diameter
- L- Body Counter Bore Depth
- L₁- Depth of Counterbore in Tooling Plate
- M- Piston Rod Thread Depth
- N₁- Diameter of Guide Rods

Notes:

- * The center sensor dovetail is omitted on the Bore 20 Cylinder.
- 1- Through holes in Tooling Plate for SZV version
- ** Thru-hole in Tooling Plate

SZV 6 Ø20-63mm

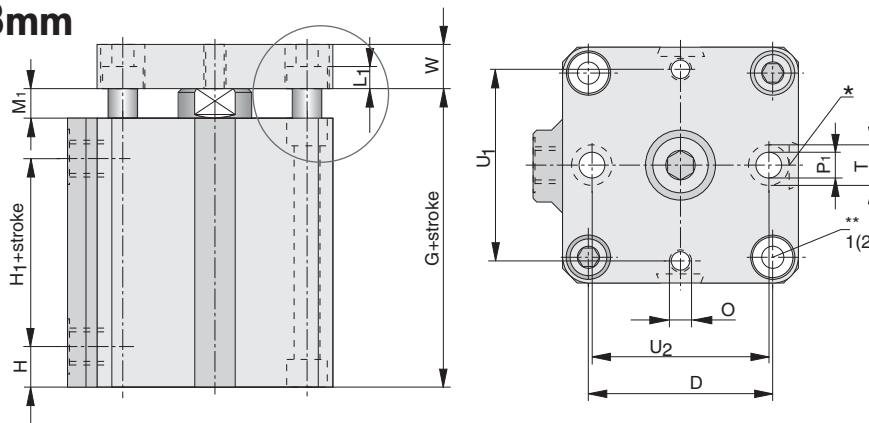

Counter Bored Holes:

The standard cylinders have thru mounting holes that are counter bored. The diagram below shows details of this feature.

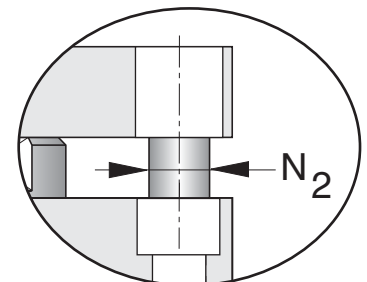

SZ Compact Cylinder



Dimensional Data

Bore Ø	A	B	C	D	E	F + stroke	G + stroke	G ₁ + 2 x stroke	H	H ₁ + stroke	J
12	0.91 23	1.06 27	0.98 25	0.68 17.2	0.51 13	1.34 34	1.52 38.5	1.69 43	0.39 10	0.55 14	0.13 3.4
16	1.10 28	1.18 30	1.10 28	0.79 20	0.79 20	1.36 34.5	1.57 40	1.79 45.5	0.39 10	0.55 14	0.13 3.4
20	1.26 32	1.34 34	1.26 32	0.87 22	0.87 22	1.42 36	1.65 42	1.89 48	0.43 11	0.55 14	0.18 4.5
25	1.46 37	1.73 44	1.54 39	1.10 28	1.02 26	1.52 38.5	1.77 45	2.03 51.5	0.45 11.5	0.61 15.5	0.18 4.5
32	1.77 45	2.05 52	1.89 48	1.42 36	1.26 32	1.54 39	1.79 45.5	2.05 52	0.35 9	0.81 20.5	0.22 5.5
40	2.17 55	2.32 59	2.17 55	1.61 41	1.61 41	1.65 42	1.89 48	2.17 55	0.35 9	0.94 24	0.26 6.7
50	2.52 64	2.83 72	2.52 64	1.97 50	1.97 50	1.77 45	2.09 53	2.40 61	0.43 11	0.91 23	0.26 6.7
63	3.15 80	3.46 88	3.15 80	2.44 62	2.44 62	2.07 52.5	2.38 60.5	2.70 68.5	0.47 12	1.12 28.5	0.33 8.5
80	3.70 94	4.09 104	3.70 94	2.87 73	2.87 73	2.24 57	2.60 66	2.95 75	0.51 13	1.22 31	0.33 8.5
100	4.61 117	4.94 125.5	4.61 117	3.56 90.5	3.56 90.5	2.30 58.5	2.70 68.5	3.09 78.5	0.55 14	1.22 31	0.41 10.5

Bore Ø	J ₁	K	L	L ₁	L ₂	M	M ₁	N	N ₂	O	P
12	8•32 M4	0.24 6	0.13 3.4		0.48 12	0.24 6		0.24 6			4•40 M3
16	8•32 M4	0.24 6	0.13 3.4		0.48 12	0.31 8		0.31 8			8•32 M4
20	1/4•20 M5	0.30 7.5	0.19 4.8	0.20 5	0.74 15	0.31 8	0.24 6	0.39 10	0.20 5	10•32 M4	10•32 M5
25	1/4•20 M5	0.30 7.5	0.19 4.8	0.20 5	0.74 15	0.47 12	0.26 6.5	0.47 12	0.20 5	10•32 M4	1/4•20 M6
32	5/16•18 M7	0.39 10	0.23 5.8	0.24 6	0.93 24	0.47 12	0.26 6.5	0.47 12	0.24 6	10•32 M5	1/4•20 M8
40	5/16•18 M8	0.43 11	0.27 6.8	0.24 6	0.93 24	0.47 12	0.24 6	0.63 16	0.24 6	10•32 M5	5/16•18 M8
50	5/16•18 M8	0.43 11	0.27 6.8	0.28 7	0.93 24	0.69 17.5	0.31 8	0.79 20	0.31 8	10•32 M6	3/8•16 M10
63	1/2•13 M10	0.55 14	0.33 8.3	0.35 9	1.49 30	0.69 17.5	0.31 8	0.79 20	0.39 10	10•32 M6	3/8•16 M12
80	1/2•13 M10	0.55 14	0.33 8.3		1.49 30	0.98 25		0.98 25			1/2•13 M16
100	1/2•13 M12	0.71 18	0.43 11		1.49 36	1.10 28		1.26 32			3/4•10 M20

Bore Ø	P ₁	Q	R	S	SW	T	U	U ₁	U ₂	V	W
12		10•32 M5	0.31 8	0.43 11	5		0.34 8.6			0.57 14.5	
16		10•32 M5	0.31 8	0.43 11	6		0.39 10			0.63 16	
20	0.18 4.5	10•32 M5	0.31 8	0.43 11	8	0.30 7.5	0.43 11	0.87 22	0.87 22	0.71 18	0.31 8
25	0.18 4.5	1/8 NPT G1/8	0.59 15	0.75 19	10	0.31 8	0.55 14	1.02 26	1.10 28	0.96 24.5	0.31 8
32	0.22 5.5	1/8 NPT G1/8	0.59 15	0.75 19	10	0.39 10	0.71 18	1.26 32	1.42 36	1.10 28	0.39 10
40	0.22 5.5	1/8 NPT G1/8	0.59 15	0.75 19	13	0.39 10	0.81 20.5	1.57 40	1.57 40	1.24 31.5	0.39 10
50	0.27 6.8	1/8 NPT G1/8	0.59 15	0.75 19	17	0.45 11.5	0.98 25	1.97 50	1.97 50	1.57 40	0.47 12
63	0.35 9	1/8 NPT G1/8	0.59 15	0.91 23	17	0.57 14.5	1.22 31	2.44 62	2.44 62	1.89 48	0.47 12
80		1/4 NPT G1/4	0.75 19	0.91 23	22		1.44 36.5			2.24 57	
100		1/4 NPT G1/4	0.75 19	0.91 23	27		1.78 45.25			2.64 67	

NOTE: SZ 7 Spring Return Version: 1" (25mm) Stroke

It is necessary to add the following to the base F & G dimensions

Bores: 16 to 25 Add 0.39" (10mm)
 32, 40 Add 0.197" (5mm)

NZK Compact Cylinder



Specifications

Characteristics	Symbol	Unit	Description
General Features			
Type			Piston Rod Cylinder
Series			NZK
Configurations			NZK6 Double Acting, Single Rod, Magnetic Piston NZK7 Single Acting, Single Rod, Magnetic Piston NZK8 Single Acting, Single Rod, Magnetic Piston
Mounting			See drawing
Tube connection			Thread
Ambient temperature range	ϑ_{min} ϑ_{max}	°C	-20 +80
Mediums - temperature range	ϑ_{max}	°C	+8
Weight (mass)		kg	See table
Installation			In any position
Medium			Filtered and lubricated or filtered and unlubricated compressed air
Lubrication			Oil mist lubrication compatible with polyurethan
Material Cylinder tube Front/Rear covers Piston rod			Aluminum Aluminum Stainless steel
Pneumatic Characteristics			
Nominal pressure	P_n	bar	6
Operating pressure	P_{min} P_{max}	bar bar	0.5 (Single acting version: 1.0) 10
Piston diameter		mm	32 40 50 63 80 100
Port size			G1/8 G1/8 G1/8 G1/8 G1/8 G1/4
Piston rod diameter		mm	12 16 20 20 25 25
Piston rod thread			M6 M6 M8 M8 M10 M12 ¹⁾ M10x1.25 M12x1.25 M16x1.5 M16x1.5 M20x1.5 M20x1.5
Stroke length		mm	Double acting version: See order instructions Single acting version: 5, 10, 15, 20, 25
Cushioning			Elastomer cushioning at both ends
Spring return force	max.	N	See diagram

Series NZK

Ø32mm - 100mm

NZK 6: Double Acting, Single Rod, Magnets

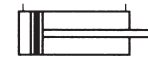

NZK 7: Single Acting, Single Rod, Magnets



NZK 8: Single Acting, Single Rod, Magnets



Features:

**Stainless Steel Rod
Magnetic Piston
Bumpers
Pre-Lubricated Design
Spring Extend or Retract
ISO 6431 Mounting Holes**

¹⁾ Piston rod thread on series NZK.../....-AG

NZK Compact Cylinder



Cylinder Details

Dimensions for Basic Cylinder

Version: Piston Rod with Female Thread (Series NZK..../...)

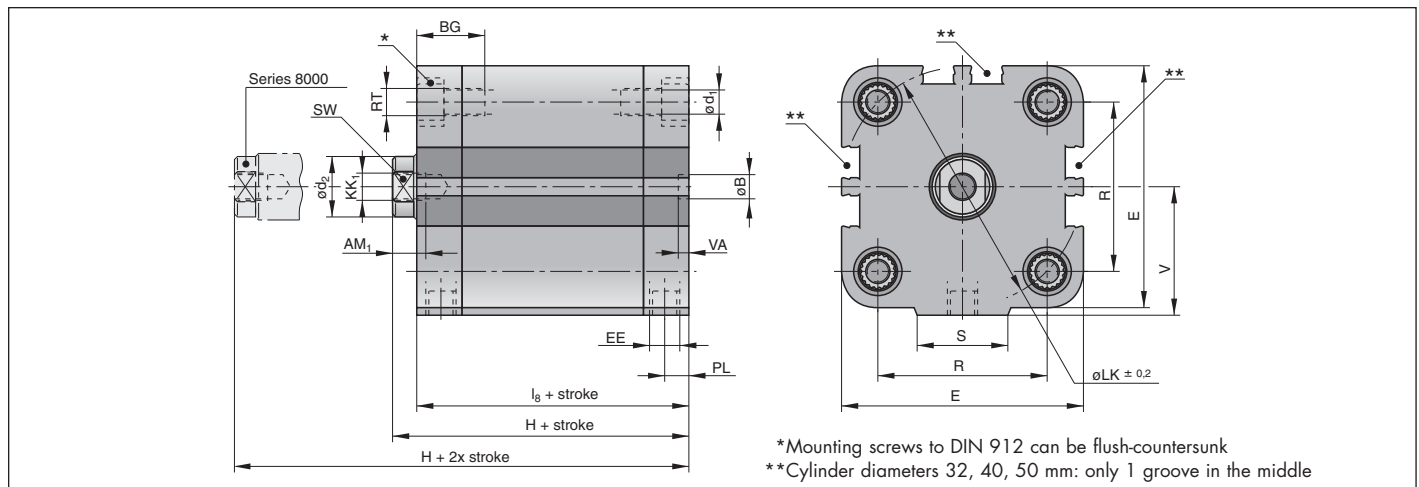

*Mounting screws to DIN 912 can be flush-countersunk
**Cylinder diameters 32, 40, 50 mm: only 1 groove in the middle

Dimension Table (mm) for Basic Cylinder

Bore ϕ	AM ₁	ϕB H9	BG	ϕd_1	ϕd_2	E	EE	H (* +stroke)	KK ₁	l_8 +stroke	ϕLK	PL	R	RT	S	SW	V	VA
32	12	6	21	5.5	12	50	G1/8	50.5	M6	44.5	46	8	32.5	M6	21	10	26.5	4
40	12	6	21	5.5	16	57	G1/8	52	M6	45.5	54	8	38	M6	22	13	30	4
50	12	6	22.5	6.5	20	67.5	G1/8	53	M8	45.5	66	8	46.5	M8	25	17	35.75	4
63	12	8	22.5	6.5	20	81	G1/8	57.5	M8	50	80	8	56.5	M8	30	17	43.5	4
80	16	8	27.5	8.5	25	98	G1/8	64	M10	56	102	8.5	72	M10	40	19	53	4
100	20	8	32.5	8.5	25	119	G1/4	76.5	M12	66.5	126	10.5	89	M10	50	22	62.5	4

*Series NZK 8000: H + 2x stroke

Dimensions for Basic Cylinder

Version: Piston Rod with Male Thread (Series NZK..../...-AG)

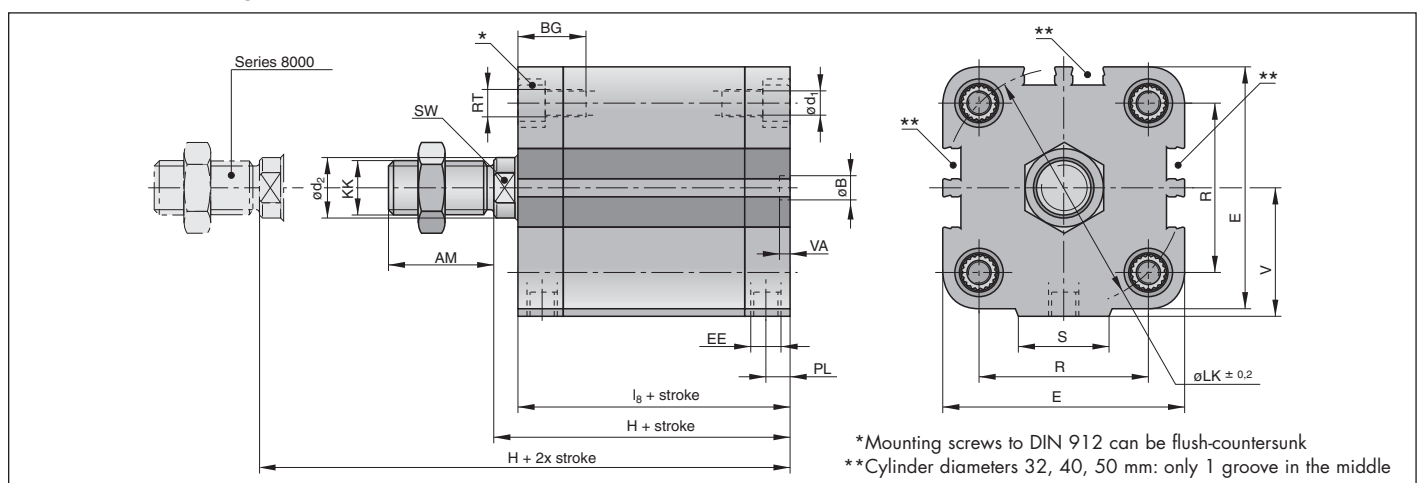

*Mounting screws to DIN 912 can be flush-countersunk
**Cylinder diameters 32, 40, 50 mm: only 1 groove in the middle

Dimension Table (mm) for Basic Cylinder

Bore ϕ	AM	ϕB H9	BG	ϕd_1	ϕd_2	E	EE	H (* +stroke)	KK ₁	l_8 +stroke	ϕLK	PL	R	RT	S	SW	V	VA
32	20	6	21	5.5	12	50	G1/8	50.5	M10x1.25	44.5	46	8	32.5	M6	21	10	26.5	4
40	24	6	21	5.5	16	57	G1/8	52	M12x1.25	45.5	54	8	38	M6	22	13	30	4
50	32	6	22.5	6.5	20	67.5	G1/8	53	M16x1.5	45.5	66	8	46.5	M8	25	17	35.75	4
63	32	8	22.5	6.5	20	81	G1/8	57.5	M16x1.5	50	80	8	56.5	M8	30	17	43.5	4
80	40	8	27.5	8.5	25	98	G1/8	64	M20x1.5	56	102	8.5	72	M10	40	19	53	4
100	40	8	32.5	8.5	25	119	G1/4	76.5	M20x1.5	66.5	126	10.5	89	M10	50	22	62.5	4

*Series NZK 8000: H + 2x stroke

NZK Compact Cylinder



Ordering Information

Description	Symbol	Bore Ø	Type #	Order #
Double acting without adjustable end cushioning, for contactless position sensing		32	NZK 6032/... NZK 6032/...-AG	PA 58390-.... PA 58470-....
		40	NZK 6040/... NZK 6040/...-AG	PA 59310-.... PA 59390-....
		50	NZK 6050/... NZK 6050/...-AG	PA 60390-.... PA 60470-....
		63	NZK 6063/... NZK 6063/...-AG	PA 61330-.... PA 61410-....
		80	NZK 6080/... NZK 6080/...-AG	PA 62230-.... PA 62310-....
		100	NZK 6100/... NZK 6100/...-AG	PA 63130-.... PA 63210-....
Single acting, normally retracted, without adjustable end cushioning for contactless position sensing		32	NZK 7032/... NZK 7032/...-AG	PA 58400-.... PA 58480-....
		40	NZK 7040/... NZK 7040/...-AG	PA 59320-.... PA 59400-....
		50	NZK 7050/... NZK 7050/...-AG	PA 60400-.... PA 60480-....
		63	NZK 7063/... NZK 7063/...-AG	PA 61340-.... PA 61420-....
		80	NZK 7080/... NZK 7080/...-AG	PA 62240-.... PA 62320-....
		100	NZK 7100/... NZK 7100/...-AG	PA 63140-.... PA 63220-....
Single acting, normally extended, without adjustable end cushioning for contactless position sensing		32	NZK 8032/... NZK 8032/...-AG	PA 58460-.... PA 58490-....
		40	NZK 8040/... NZK 8040/...-AG	PA 59360-.... PA 59410-....
		50	NZK 8050/... NZK 8050/...-AG	PA 60460-.... PA 60490-....
		63	NZK 8063/... NZK 8063/...-AG	PA 61400-.... PA 61430-....
		80	NZK 8080/... NZK 8080/...-AG	PA 62300-.... PA 62330-....
		100	NZK 8100/... NZK 8100/...-AG	PA 63200-.... PA 63230-....
<p>Complete type designation and order no. with stroke length in mm (4-digits)</p> <p>Stroke Length: MM (standard) Double acting Version: —any mm increment up to 500mm standard Single acting Version: —0005,0010,0015,0020,0025 Contact factory for special stroke lengths</p>				

Description	Bores					
	32mm	40mm	50mm	63mm	80mm	100mm
Foot mounting A-..	PD 27917	PD 27918	PD 28072	PD 28073	PD 28074	PD 28075
Rear trunnion mounting B-..	PD 22704	PD 22705	PD 22706	PD 22707	PD 22708	PD 22709
Rear trunnion mounting BA-..	PD 23412	PD 23413	PD 23414	PD 23415	PD 23416	PD 23417
Rear trunnion mounting BAS-..*	PD 23843	PD 23844	PD 23845	PD 23846	PD 23847	PD 23848
Front flange mounting C-..	PD 23403	PD 23404	PD 23405	PD 23406	PD 23407	PD 23408
Rear flange mounting D-..	PD 23403	PD 23404	PD 23405	PD 23406	PD 23407	PD 23408
Security bolt for mountings B,BA,BAS	KY 6153	KY 6154	KY 6157	KY 6156	KY 6158	KY 6159
Delivery information: on delivery all cylinder mountings, except the trunnion mounting are not assembled						

WST Stopper Cylinder



Specifications

Features		
Media	Clean dry compressed air	
Operating Pressure Range	22 to 102 psi (1.5 to 7 Bar)	
Max* Pressure	145 psi (10 Bar)	
Operating Temperature Range	32 to 140°F (0 to 60°C)	
Operating Speed Range mm/s	50-500	
Cushion	Urethane Bumper	
Connecting Port	G1/8" (BSP)	
Lubrication	Sealed, lubricated for life	
Shock Absorber	WSAB2012-R	WSAB3625-C
Mounting Type	Flange	Plate
Stroke Tolerance	0-1.5mm	
Bore Size and Stroke Length		
Model	Bore Size	Stroke
WSTV(S)	50, 80	30
WSTSV(S)	50, 80	30
WSTH(S)	50	50

*The units are not designed to operate at this pressure. Exceeding the operating pressure range may cause damage to reduce the life of the unit.

Series WST Ø50mm & 80mm

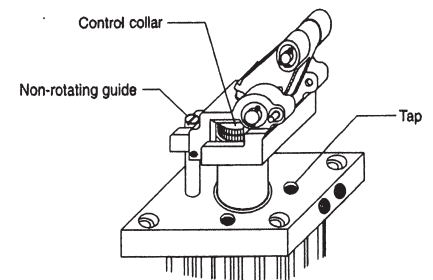

How to adjust the shock absorber

The shock absorber is set to maximum damping upon delivery. When in operation, adjust the damping of the shock absorber by adjusting the control collar. For the vertical model, it's shown above. For the horizontal model, by the graduated collar.

Gradually reduce the damping level until the load comes to rest in the correct position, without any shock deceleration of the load.

If the load forces the damper to its fully retracted position too rapidly (normally apparent due to a sudden deceleration at the end of stroke), then this may lead to mechanical damage of the unit. In this case, increase the damping to remove the shock deceleration.

Periodically regulate the damping of each unit to maintain the shock absorber energy higher than the apparent load energy.

Shock absorber replacement

If correctly set, the shock absorber will operate trouble free.

Vertical type

Unfasten the head using a spanner while holding the cylinder rod in place.

Replace the shock absorber on the piston rod.

Refasten the head and readjust the shock absorber.

Horizontal type

Loosen and remove the locking collar. Remove the shock absorber and replace it.

Precautions

1. Please note that if the impact energy exceeds the shock absorber energy that is currently set then the cylinder and frame will absorb the excess energy.
2. Keep all moving parts free from scratches or defects, as they may lead to defective operation.
3. The unit must be securely fastened to a fixed surface, to prevent free rotation. Any rotation may lead to incorrect operation or damage.
4. Please keep clear of all moving parts during operation.
5. The sensors are secured by a thread fixing with the mounting slots along the side of the cylinder.
To reposition a sensor:
Loosen the threaded fastener.
Slide the sensor along the groove to its new position.
Tighten the threaded fastener locking the sensor in place.

WST Stopper Cylinder



Ordering Information

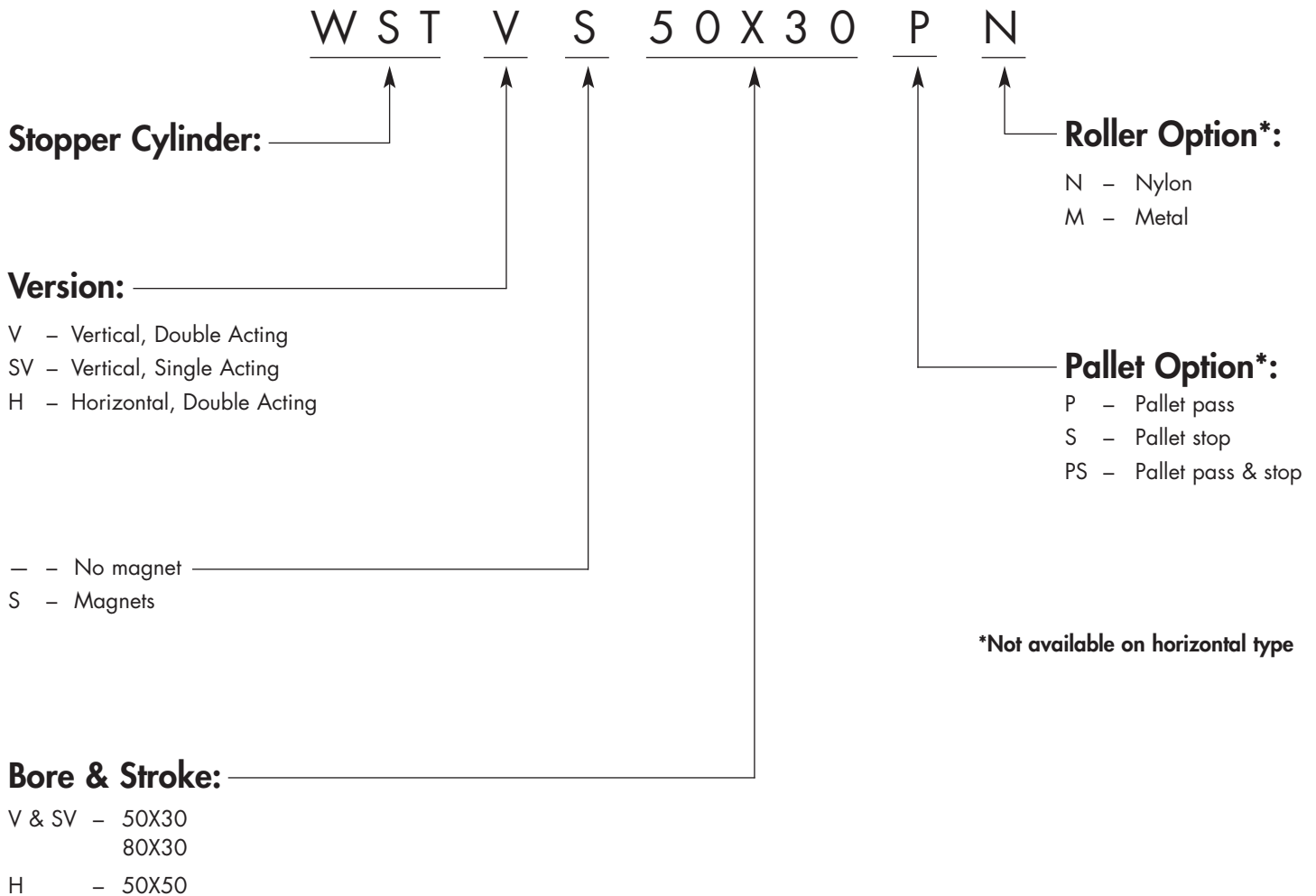

Proximity Sensors

Order #	Description
WE102A/B	Reed Type, 2 wire cable, DC10-28V, AC85-115V
WE155A/B	Reed Type, 3 wire cable, LED, DC4.5V-28V
WS3HA/B	Reed Type, 2 wire cable, LED, DC10-30V (10-50mA), AC85-115V (10-50nA)
WS4HA/B	Reed Type, 2 wire cable, LED, DC10-30V (5-25mA), AC85-115V (5-20nA)
WS9HA/B	Reed Type, 3 wire cable, LED, DC4.5-28V (10-50mA)

WST Stopper Cylinder



Cylinder Sizing

Type – WSTV(S), WSTSV(S)

Pressure vs Load

Graph 1

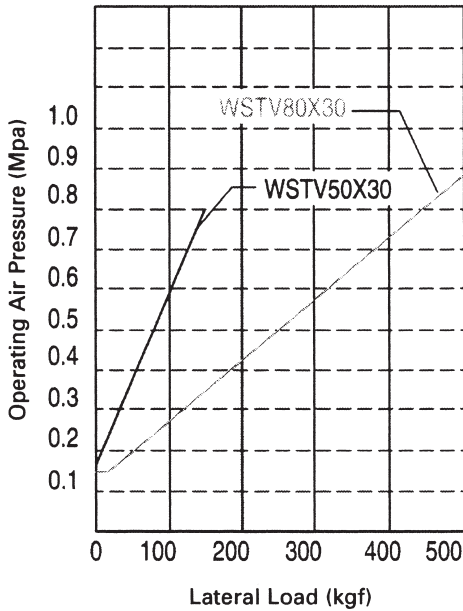

Load vs Speed

Graph 2

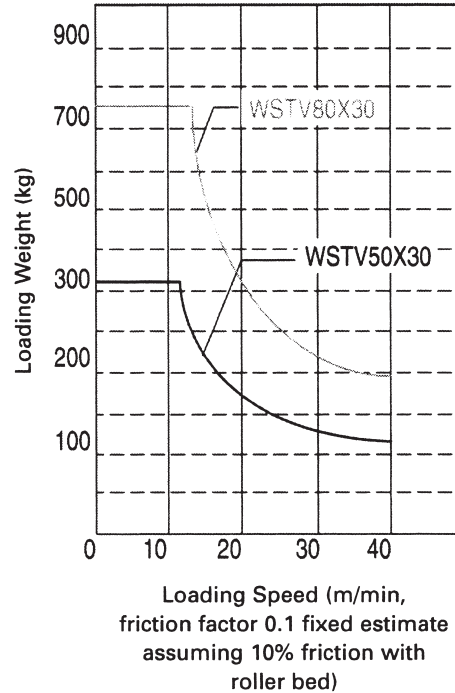

Example for selection of stopper cylinder

Check the requirements:

1. Loading speed
2. Loading weight
3. Operating pressure



Bore size selection:

1. Select the cylinder size from Graph 2 using the loading speed and weight
2. Check the estimated operating pressure from Graph 1

For example: A load of 200kg travelling at 15m/min with an estimated friction factor of 0.1.
 Cross referencing 200kg and 15m/min on Graph 2 gives a WSTV 50x30.
 Checking on Graph 1 with a lateral load of $0.1 \times 200\text{kg} = 20\text{kg}$ on a WSTV 50x30.
 This is below the graph line showing it to be acceptable for the application.

WST Stopper Cylinder



Cylinder Sizing

Type – WSTH(S)

Pressure vs Load

Graph 1

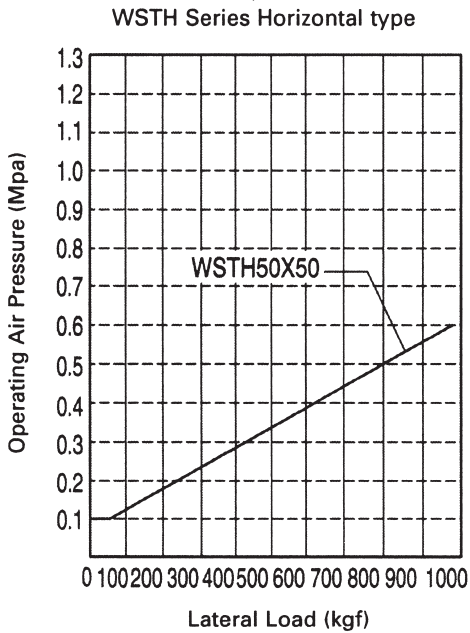

Load vs Speed

Graph 2

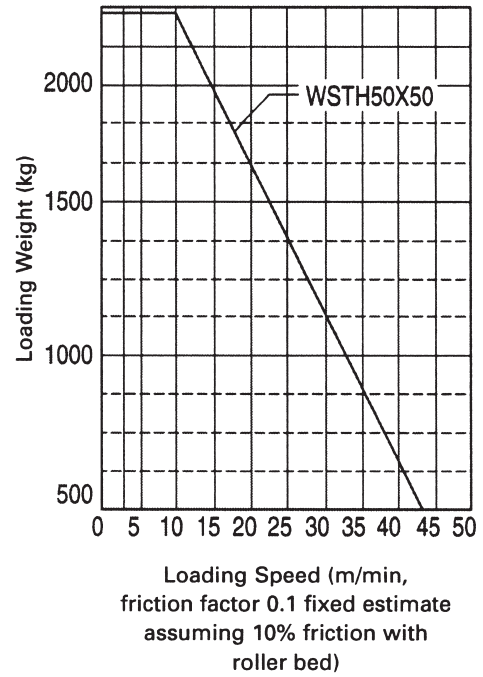

Example

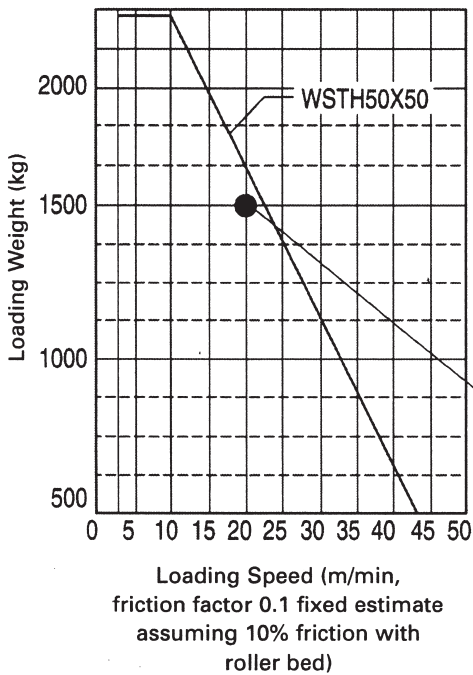

1. Specify load weight
2. Specify load speed
3. Check that it falls within the graph line

For example:
Mass of 1500kg with a speed of 20m/min is below the line making it acceptable for a WSTH 50x50

AZ Cylinder



Specifications

Features	
Type	ISO 6431 VDMA 24562 CETOP RP43P
Series	AZ
Configurations	AZ Double Acting, Single Rod, Magnetic Piston, Cushions AZD Double Acting, Double Rod, Magnetic Piston
Construction Materials	
Barrel	Extruded Aluminum, Anodized (10µ)
End Caps	Die Cast Aluminum
Piston Rod	Stainless Steel
Rod Bearing	Teflon Impregnated Bronze
Piston	Molded NBR, (Optional: Viton)
Cushions Needle	Brass
Seals	Urethane, (Optional: Viton)
End Cap Screws	Steel, zinc plated
Characteristics	
Operating Temperature	Min: -5° F (-20°C) Max: +176 °F (+80°C)
Operating Pressure	Min: 15 PSI (1 bar) Max: 145 PSI (10 bar)
Normal Operating Pressure	90 PSI (6 bar)
Lubrication	Pre-lubricated at factory. If additional lubrication is required use oil compatible for NBR seal and designed for use in pneumatic systems.
Media	Filtered and regulated compressed air
Installation	In any position
Weight	See chart with mounts
Stroke Length	Up to 500mm - Longer contact factory
Theoretical Forces	See Technical Information Sheet
Load Capacity	See Technical Information Sheet
Specifications	
Piston Diameter	32 40 50 63 80 100
Port Sizes	Metric (G) G1/8 G1/4 G1/4 G3/8 G3/8 G1/2
Rod Diameter	mm 12 16 20 20 25 25
Cushion Lengths All Cylinders	mm 21 25 28 30 30 37

Series AZ

Ø32mm - 100mm

ISO 6431
VDMA 24562
CETOP RP43P

**AZ 5: Double Acting, Single Rod,
Magnets, Cushions**

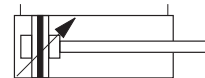

**AZD 6: Double Acting, Double Rod,
Magnets**



Features:

**Stainless Steel Rod
Magnetic Piston
Adjustable Cushions
Pre-Lubricated Design
Captive Cushion Needles**

AZ Cylinder



Ordering Information

Example: AZ 5050/25-V
 ISO 6431
 Single Rod
 Double Acting, Magnets, Cushions
 50mm Bore
 25mm Stroke
 Viton Seals

AZ 5050 / 25 - V

Versions:

AZ - Single Rod
 AZD - Double Rod

Actuation:

Standard

5 - Double Acting, Magnets, Cushions
 1 - Double Acting, Cushions
 6 - Double Acting, Magnets
 2 - Double Acting

Options:

- - Standard
 V - Viton
 D2L - Front, Single End Porting
 B2L - Rear, Single End Porting

Stroke:

MM: (standard)
 • any mm increment up to 500mm standard
 • contact factory for special stroke lengths

Bore:

032 - 32 mm (nom. 1-1/4")
 040 - 40 mm (nom. 1-1/2")
 050 - 50 mm (nom. 2")
 063 - 63 mm (nom. 2-1/2")
 080 - 80 mm (nom. 3-1/8")
 100 - 100 mm (nom. 4")
 Contact factory for bore sizes: 125, 160, 200, 250, and 320mm.

Proximity Sensors/Brackets: See Page 73

Description	Bore Ø					
	32mm	40mm	50mm	63mm	80mm	100mm
Foot bracket, Type A	PD 27917	PD 27918	PD 28072	PD 28073	PD 28074	PD 28075
Rear double clevis, Type B	PD 22704	PD 22705	PD 22706	PD 22707	PD 22708	PD 22709
Rear single clevis, Type BA	PD 23412	PD 23413	PD 23414	PD 23415	PD 23416	PD 23417
Rear single clevis w/bearing, Type BAS	PD 23843	PD 23844	PD 23845	PD 23846	PD 23847	PD 23848
Front flange, Type C	PD 23403	PD 23404	PD 23405	PD 23406	PD 23407	PD 23408
Rear flange, Type D	PD 23403	PD 23404	PD 23405	PD 23406	PD 23407	PD 23408
Center trunnion, Type EN	PD 39195	PD 39196	PD 39197	PD 39198	PD 39199	PD 39200
Clevis Pin for mounting types B, BA, BAS	KY 6153	KY 6154	KY 6157	KY 6156	KY 6158	KY 6159

Delivery information: all cylinder mountings, except the trunnion mounting, are shipped unassembled

AZ Cylinder



Dimensional Data

AZ Ø32-100mm

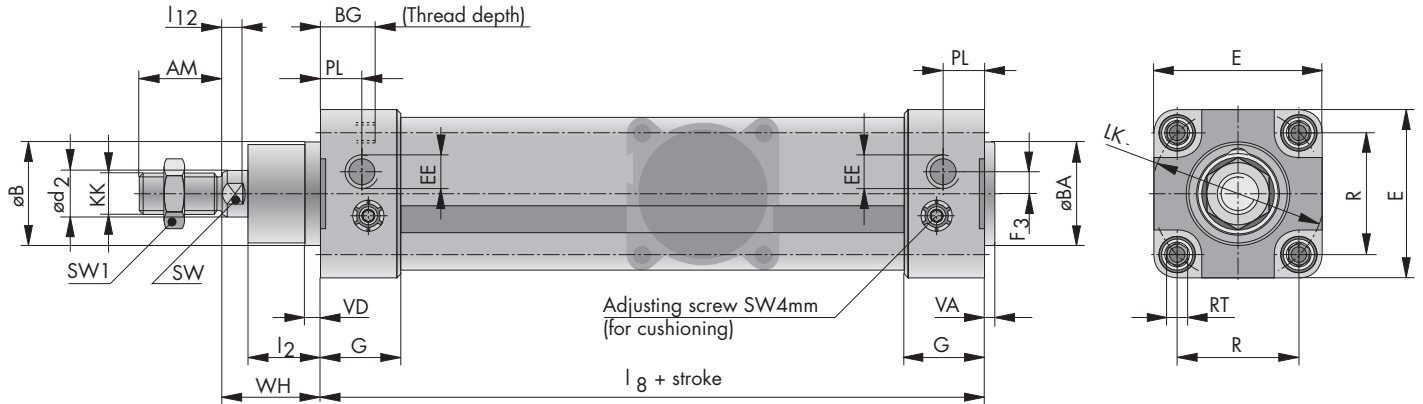

AZD Ø32-100mm

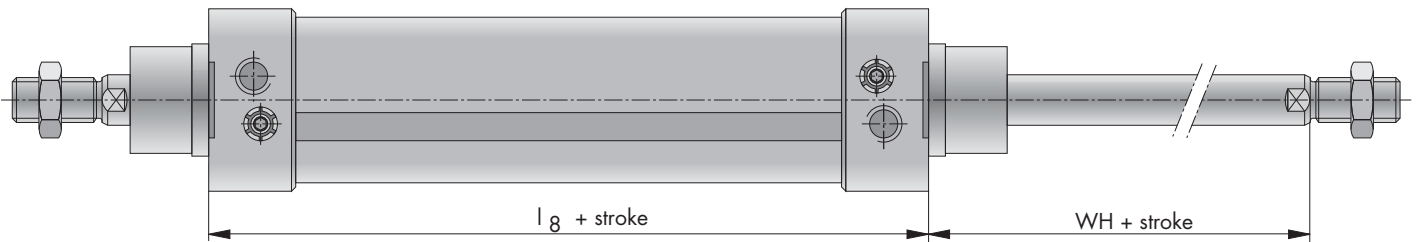

Bore ϕ	AM	ϕB	ϕBA	BG	ϕd	E	EE	F_3	G	KK	l_2	$l_8 + \text{stroke}$	l_{12}	ϕLK	PL	R	RT	SW	SW ₁	VA	VD	WH + stroke
32	0.79	1.18	1.18	0.63	0.47	1.85	1/8 NPT	0.18	1.20	3/8-24	0.79	3.70	0.24	1.81	0.39	1.28	1/4-20	0.39	0.67	0.16	0.20	1.02
	20	30	30	16	12	47	G1/8	4.5	30.5	M10 X 1.25	20	94	6	46	9.8	32.5	M6	10	17	4	5	26
40	0.94	1.38	1.38	0.63	0.63	2.17	1/4 NPT	0.21	1.34	7/16-20	0.81	4.13	0.26	2.13	0.57	1.50	1/4-20	0.51	0.75	0.16	0.30	1.18
	24	35	35	16	16	55	G1/4	5.3	34	M12 X 1.25	20.5	105	6.5	54	14.5	38	M6	13	19	4	5	30
50	1.26	1.57	1.57	0.63	0.79	2.56	1/4 NPT	0.33	1.22	5/8-18	1.10	4.17	0.31	2.60	0.63	1.83	5/16-18	0.67	0.94	0.16	0.24	1.46
	32	40	40	16	20	65	G1/4	8.5	31	M16 X 1.50	28	106	8	66	16	46.5	M8	17	24	4	6	37
63	1.26	1.77	1.77	0.63	0.79	3.07	3/8 NPT	0.31	1.30	5/8-18	1.02	4.76	0.31	3.15	0.63	2.22	5/16-18	0.67	0.94	0.16	0.24	1.46
	32	45	45	16	20	78	G3/8	8	33	M16 X 1.50	26	121	8	80	16	56.5	M8	17	24	4	6	37
80	1.57	1.77	1.77	0.63	0.98	3.74	3/8 NPT	0.35	1.40	3/4-16	1.28	5.04	0.39	4.02	0.81	2.83	3/8-16	0.87	1.18	0.16	0.24	1.81
	40	45	45	16	25	95	G3/8	9	35.5	M20 X 1.50	32.5	128	10	102	20.5	72	M10	22	30	4	6	46
100	1.57	2.17	2.17	0.63	0.98	4.53	1/2 NPT	0.51	1.46	3/4-16	1.48	5.43	0.39	4.96	0.75	3.50	3/8-16	0.87	1.18	0.16	0.24	2.01
	40	55	55	16	25	115	G1/2	13	37	M20 X 1.50	37.5	138	10	126	19	89	M10	22	30	4	6	51

AZ Cylinder



Cylinder Mounts

Foot Bracket- Type A

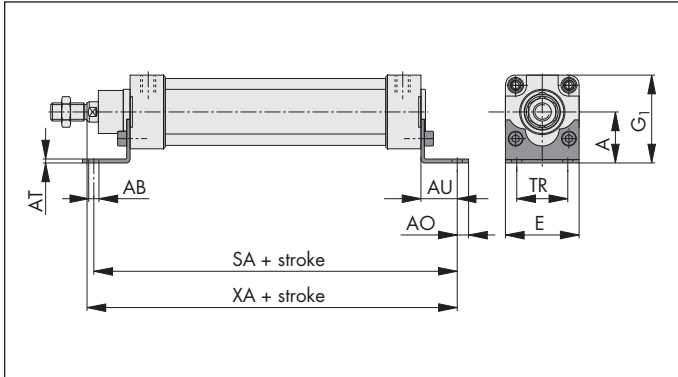

Bore ø	AB	AH	AO	AT	AU	E	G ₁	TR	SA+ stroke	XA+ stroke
32	0.28	1.26	0.31	0.12	0.94	1.85	2.19	1.26	5.59	5.67
	7	32	8	3	24	47	55.5	32	142	144
40	0.35	1.42	0.39	0.12	1.10	2.09	2.46	1.42	6.34	6.42
	9	36	10	3	28	53	62.5	36	161	163
50	0.35	1.77	0.39	0.12	1.26	2.56	3.05	1.77	6.69	6.89
	9	45	10	3	32	65	77.5	45	170	175
63	0.35	1.97	0.39	0.12	1.26	2.95	3.44	1.97	7.28	7.48
	9	50	10	3	32	75	87.5	50	185	190
80	0.47	2.48	0.55	0.16	1.61	3.74	4.35	2.48	8.27	8.46
	12	63	14	4	41	95	110.5	63	210	215
100	0.55	2.80	0.59	0.16	1.61	4.53	5.06	2.95	8.66	9.06
	14	71	15	4	41	115	128.5	75	220	23

Rear Double Clevis- Type B

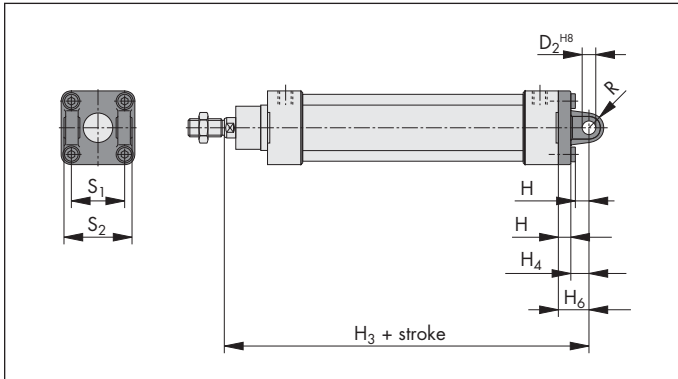

Bore ø	øD H8	H ₃ + stroke	H ₄	H ₆	H ₇	H ₈	R	S ₁	S ₂
32	0.39	5.59	0.47	0.87	0.43	0.39	0.35	1.02	1.77
	10	142	12	22	11	10	9	26	45
40	0.47	6.30	0.59	0.98	0.55	0.39	0.43	1.10	2.05
	12	160	15	25	14	10	11	28	52
50	0.47	6.69	0.63	1.06	0.59	0.43	0.47	1.26	2.36
	12	170	16	27	15	11	12	32	60
63	0.63	7.48	0.83	1.26	0.79	0.43	0.59	1.57	2.76
	16	190	21	32	20	11	15	40	70
80	0.63	8.27	0.87	1.42	0.83	0.55	0.63	1.97	3.54
	16	210	22	36	21	14	16	50	90
100	0.79	9.06	0.98	1.61	0.94	0.63	0.79	2.36	4.33
	20	230	25	41	24	16	20	60	110

Rear Single Clevis- Type BA

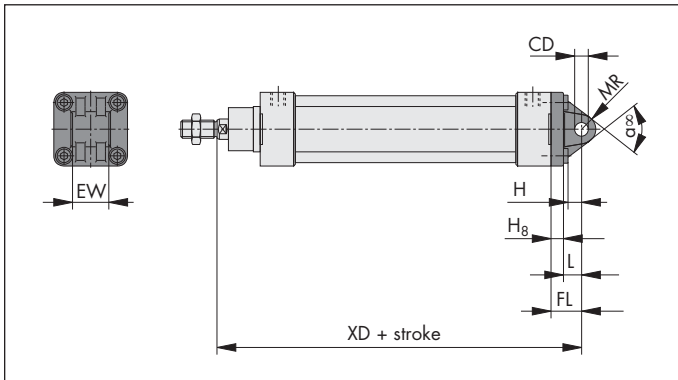

Bore ø	øCD H8	EW	FL	H ₇	H ₈	L	MR	XD+ stroke	α
32	0.39	1.02	0.87	0.43	0.39	0.47	0.41	5.59	2.36
	10	26	22	11	10	12	10.5	142	60
40	0.47	1.10	0.98	0.55	0.39	0.59	0.51	6.30	2.36
	12	28	25	14	10	15	13	160	60
50	0.47	1.26	1.06	0.59	0.43	0.63	0.51	6.69	2.76
	12	32	27	15	11	16	13	170	70
63	0.63	1.57	1.26	0.79	0.43	0.83	0.67	7.48	2.36
	16	40	32	20	11	21	17	190	60
80	0.63	1.97	1.42	0.79	0.59	0.83	0.67	8.27	2.76
	16	50	36	20	15	21	17	210	70
100	0.79	2.36	1.61	0.94	0.63	0.98	0.83	9.06	2.76
	20	60	41	24	16	25	21	230	70

Rear Single Clevis with Spherical Bearing- Type BAS

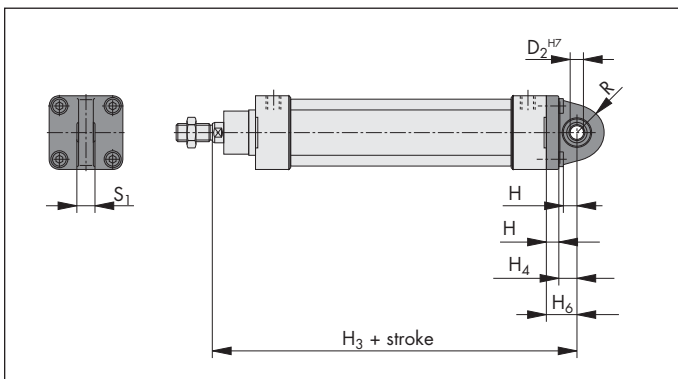

Bore ø	øD ₂ H7	H ₃ + stroke	H ₄	H ₆	H ₇	H ₈	R	S ₁
32	0.39	5.59	0.47	0.87	0.43	0.39	0.71	0.55
	10	142	12	22	11	10	18	14
40	0.47	6.30	0.59	0.98	0.55	0.39	0.83	0.63
	12	160	15	25	14	10	21	16
50	0.47	6.69	0.63	1.06	0.59	0.43	0.91	0.63
	12	170	16	27	15	11	23	16
63	0.63	7.48	0.83	1.26	0.79	0.43	1.06	0.83
	16	190	21	32	20	11	27	21
80	0.63	8.27	0.83	1.42	0.79	0.59	1.14	0.83
	16	210	21	36	20	15	29	21
100	0.79	9.06	0.98	1.61	0.94	0.63	1.34	0.98
	20	230	25	41	24	16	34	25

AZ Cylinder



Cylinder Mounts

Front Flange- Type C

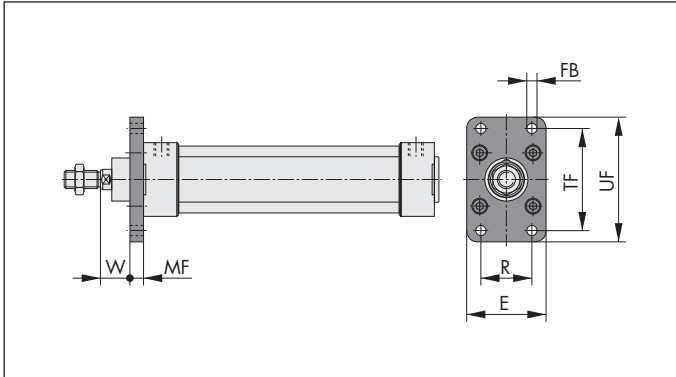

Bore \varnothing	\varnothing FB	E	MF	R	TF	UF	W
32	0.28	1.97	0.39	1.26	2.52	3.11	0.63
	7	50	10	32	64	79	16
40	0.35	2.20	0.39	1.42	2.83	3.54	0.79
	9	56	10	36	72	90	20
50	0.35	2.76	0.47	1.77	3.54	4.33	0.98
	9	70	12	45	90	110	25
63	0.35	3.03	0.47	1.97	3.94	4.72	0.98
	9	77	12	50	100	120	25
80	0.47	3.94	0.63	2.48	4.96	6.02	1.18
	12	100	16	63	126	153	30
100	0.55	4.72	6.30	2.95	5.91	7.01	1.38
	14	120	160	75	150	178	35

Rear Flange- Type D

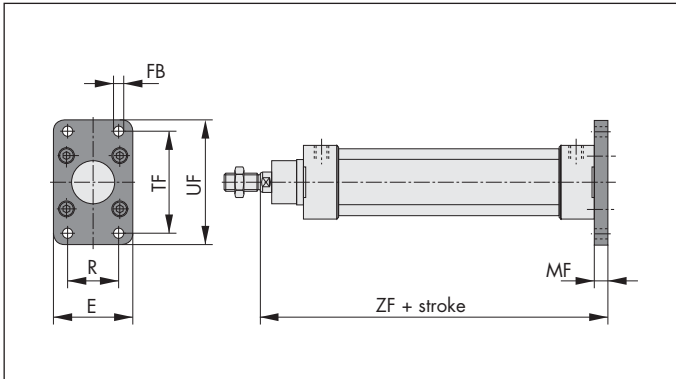

Bore \varnothing	\varnothing FB	E	MF	R	TF	UF	ZF+ stroke
32	0.28	1.97	0.39	1.26	2.52	3.11	5.12
	7	50	10	32	64	79	130
40	0.35	2.20	0.39	1.42	2.83	3.54	5.71
	9	56	10	36	72	90	145
50	0.35	2.76	0.47	1.77	3.54	4.33	6.10
	9	70	12	45	90	110	155
63	0.35	3.03	0.47	1.97	3.94	4.72	6.69
	9	77	12	50	100	120	170
80	0.47	3.94	0.63	2.48	4.96	6.02	7.48
	12	100	16	63	126	153	190
100	0.55	4.72	0.63	2.95	5.91	7.01	8.07
	14	120	16	75	150	178	205

Adjustable Trunnion- Type EN

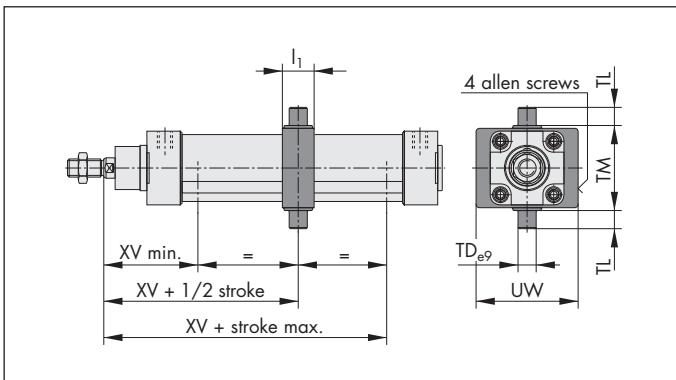

Bore \varnothing	l_1	\varnothing TD e9	TL	TM	UW	XV min.	XV+ 1/2 stroke	XV+ max. stroke
32	0.98	0.47	0.47	1.97	2.56	2.64	2.87	3.11
	25	12	12	50	65	67	73	79
40	1.10	0.63	0.63	2.48	2.95	2.83	3.27	3.70
	28	16	16	63	75	72	83	94
50	1.10	0.63	0.63	2.95	3.35	3.19	3.54	3.90
	28	16	16	75	85	81	90	99
63	1.42	0.79	0.79	3.54	3.94	3.35	3.86	4.37
	36	20	20	90	100	85	98	111
80	1.42	0.79	0.79	4.33	4.72	3.90	4.33	4.76
	36	20	20	110	120	99	110	121
100	1.89	0.98	0.98	5.20	5.31	4.21	4.72	5.24
	48	25	25	132	135	107	120	133

Trunnion Blocks- Type EL

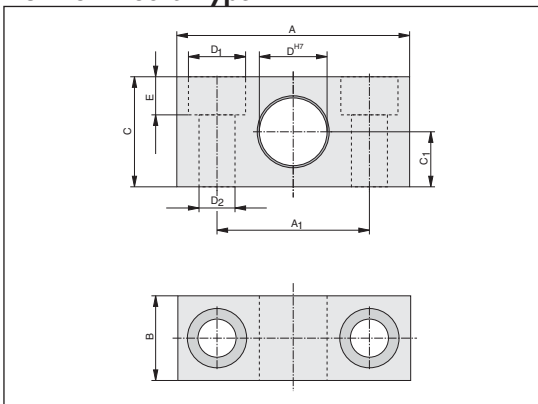

Order #	Bore \varnothing	A	A ₁	B	C	C1	\varnothing D ₁₇	\varnothing D ₁	\varnothing D ₂	E	Weight lbs (kg)
PD 23381	32	2.17	1.42	0.79	1.02	0.51	0.47	0.53	0.33	0.35	0.13
		55	36	20	26	13	12	13.5	8.4	9	0.060
PD 23382	40, 50	2.17	1.42	0.79	1.02	0.51	0.63	0.53	0.33	0.35	0.13
		55	36	20	26	13	16	13.5	8.4	9	0.060
PD 23383	63, 80	2.56	1.65	0.98	1.18	0.59	0.79	0.65	0.41	0.43	0.22
		65	42	25	30	15	20	16.5	10.5	11	0.100
PD 23384	100, 125	2.95	1.97	1.10	1.57	0.79	0.98	0.75	0.51	0.51	0.39
		75	50	28	40	20	25	19	13	13	0.175

90° Pivot Mount - to VDMA 24562

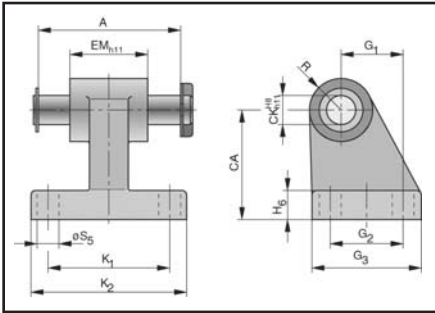

Order #	Bore Ø	A	CA	CK ^{H8} _{h11}	EM _{h11}	G ₁	G ₂	G ₃	H ₆	K ₁	K ₂	R ₁	ØS ₅	Wt. lbs (kg)
PD 40844	32	46	32	10	26	21	18	31	8	38	50	10	6.6	0.092
PD 40845	40	53	36	12	28	24	22	35	10	41	53	11	6.6	0.131
PD 40846	50	61	45	12	32	33	30	45	12	50	64	13	9	0.193
PD 40847	63	71	50	16	40	37	35	50	12	52	66	15	9	0.305
PD 40848	80	91	60	16	50	47	40	60	14	66	84	15	11	0.460
PD 40849	100	111	70	20	60	55	50	70	15	76	94	19	11	0.840

Valve Mounting Plate Ø32-100mm

Mounting Holes:

- A = 5/2-way valve; 1/4" NPT
- B = 5/2-way valve; 1/8" NPT
- C = 3/2-way valve; 1/4" NPT
- D = 3/2-way valve; 1/8" NPT

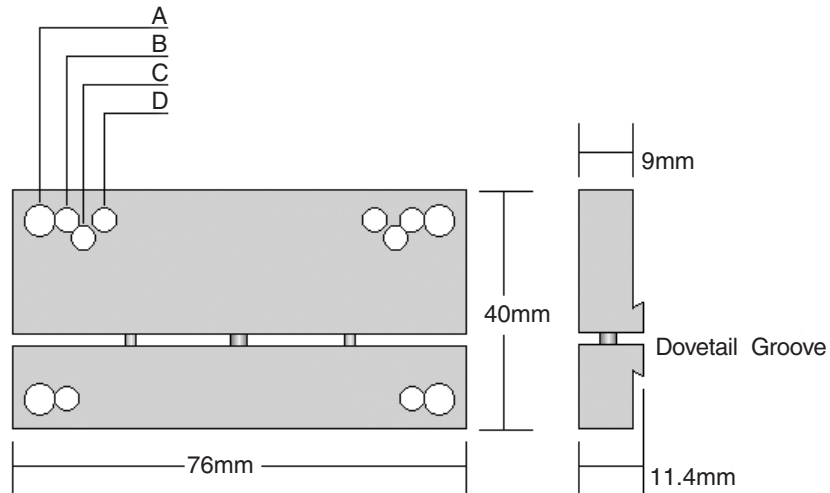

Typical Valve Installation Using Valve Mounting Plate

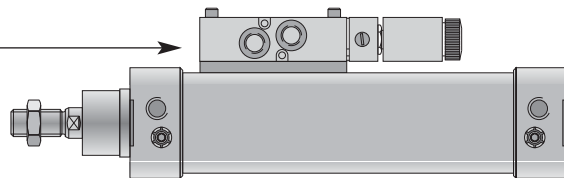

Order #: PD 40372

Ordered as a separate item
 This adapter plate is used primarily to mount our S9 series valves
 Size: 1/8" or 1/4"
 Style: 3/2-way or 5/2-way

The plate may also be used for attachment of machine components or other hardware

This adapter plate can also be used with the Series SZ, SZV, NZK, NZKV, and AZV cylinders

Rod Mounts

Rod Clevis with Pin

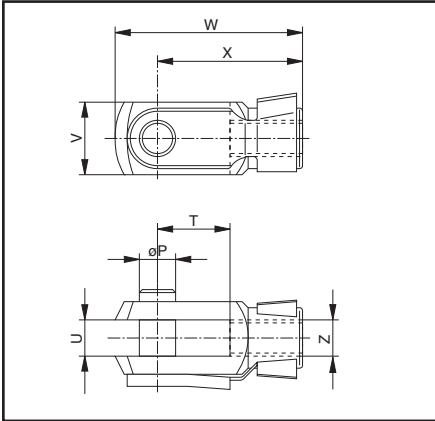

Order #	Bore Ø	Ø P	T	U	V	W	X	Z	Weight lbs (kg)
KY 6135	32	0.39 10	0.79 20	0.39 10	0.79 20	2.05 52	1.57 40	-- M10x1.25	0.18 0.08
KY 6136	40	0.47 12	0.94 24	0.47 12	0.94 24	2.44 62	1.89 48	-- M12x1.25	0.28 0.125
KY 6139	50, 63	0.63 16	1.26 32	0.63 16	1.26 32	3.27 83	2.52 64	-- M16x1.5	0.66 0.3
KY 6141	80, 100	0.79 20	1.57 40	0.79 20	1.57 40	4.13 105	3.15 80	-- M20x1.5	1.15 0.52
KY 6142	125	0.98 25	1.97 50	0.98 25	1.97 50	5.20 132 max.	3.94 100	-- M24x2	2.38 1.08
KY 6866	125	1.18 30	2.13 54	1.18 30	2.17 55	5.83 148 max.	4.41 112	-- M27x2	3.31 1.5

Rod Eye with Spherical Bearing

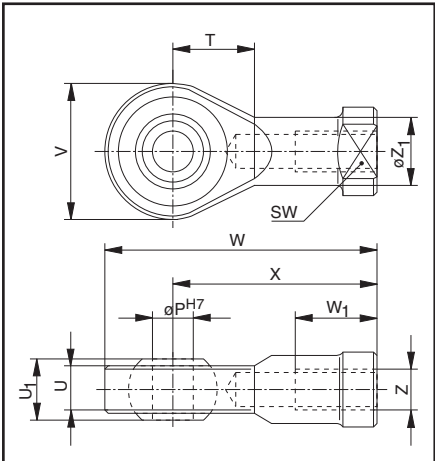

Order #	Bore Ø	ØP _{H7}	T	U	U ₁	V	W	W ₁	X	Z	Ø Z ₁	SW	Weight lbs (kg)
KY 6147	32	0.39 10	0.59 15	0.41 10.5	0.55 14	1.10 28	2.24 57	0.79 20	1.69 43	-- M10x1.25	0.59 15	17	0.16 0.072
KY 6148	40	0.47 12	0.67 17	0.47 12	0.63 16	1.26 32	2.60 66	0.87 22	1.97 50	-- M12x1.25	0.69 17.5	19	0.24 0.107
KY 6150	50, 63	0.63 16	0.87 22	0.59 15	0.83 21	1.65 42	3.35 85	1.10 28	2.52 64	-- M16x1.5	0.87 22	22	0.46 0.21
KY 6151	80, 100	0.79 20	1.02 26	0.71 18	0.98 25	1.97 50	4.02 102	1.30 33	3.03 77	-- M20x1.5	1.08 27.5	32	0.84 0.38
KY 6152	125	0.98 25	1.22 31	0.87 22	1.22 31	2.36 60 ₁₎	4.88 124 ₁₎	1.65 42 ₂₎	3.70 94	-- M24x2	1.32 33.5	36	2.56 0.65

- 1) Maximum- dimension
2) Minimum- dimension

Rod Alignment Coupler

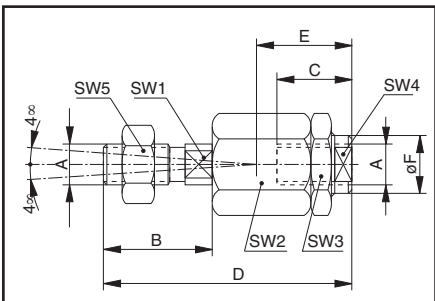

Order #	Bore Ø	A	B	C	D	E	ØF	SW1	SW2	SW3	SW4	SW5	Weight lbs (kg)
KY 1129	32 M10x1.25	0.79 20	0.91 23	2.76 70	1.22 31	0.85 21.5	12	30	30	19	17	0.01 0.218	
KY 1131	40 M12x1.25	0.91 23	0.91 23	2.64 67	1.22 31	0.85 21.5	12	30	30	19	19	0.01 0.207	
KY 1133	50 63 M16x1.5	1.57 40	1.26 32	4.41 112	1.77 45	1.32 33.5	19	41	41	30	30	0.03 0.637	
KY 1134	80 100 M20x1.5	1.54 39	1.65 42	4.80 122	2.20 56	1.32 33.5	19	41	41	30	30	0.03 0.711	

Angular Compensation

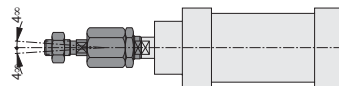

Radial Compensation for the Center Axis

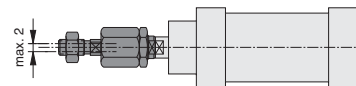

Dimensions: **Bold: INCH**, Std.: mm

AZ Cylinder



Single End Porting

-B2L Rear, Single End Porting Ø32-100mm

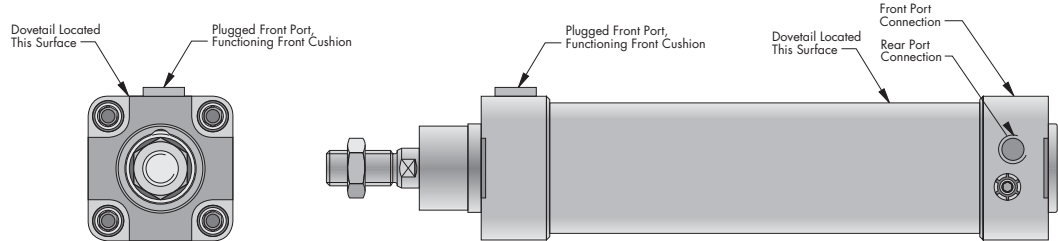

-D2L Front, Single End Porting Ø32-100mm

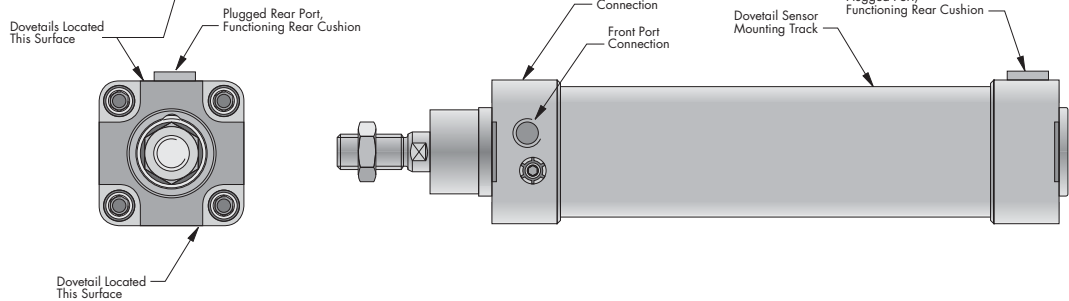

Single End Porting

Either the front or the rear end cap can be supplied with Single End Porting. An internal connection is made utilizing the galleries which have been extruded into the cylinder barrel.

The maximum potential speed of the cylinder in the retract (-B2L) or extend (-D2L) modes is limited due to the diameter of the cross-over hole in the barrel. See The following chart.

Deviation in speed (in./sec.) Ref. Cyl. AZ5XXX/6" Stroke (150mm)

Bore Ø	32mm	40mm	50mm	63mm
Extend				
Standard Cylinder	0.09	0.11	0.17	0.20
Single End Port	0.23	0.23	0.26	0.41
Retract				
Standard Cylinder	0.09	0.13	0.19	0.27
Single End Port	0.12	0.24	0.28	0.33

DZ Cylinder



Specifications

Characteristics according to VDI 3294										
Characteristics	Symbol	Unit	Description							
General Features										
Type			Piston rod cylinder							
Series			DZ1, DZ5							
System			Double acting with cushioning							
Mounting			See drawing							
Tube connection			Thread							
Ambient temperature range	\varnothing_{\min} \varnothing_{\max}	°C	-20	Note: When using below freezing point (°C) it is necessary to consult us						
Medium temperature range	\varnothing_{\min}	°C	+80							
Weight (mass)		kg	See table							
Installation			In any position							
Medium			Filtered and lubricated or filtered and unlubricated compressed air							
Lubrication			Oil mist lubrication compatible with Buna N							
Material	Cylinder tube		Aluminum							
	Front/Rear covers		Aluminum							
	Piston rod		Steel, hard-chrome plated							
Pneumatic Characteristics										
Nominal pressure	p_n	bar	6							
Operating pressure range	p_{\min}	bar	1							
	p_{\max}	bar	10							
Piston diameter		mm	125	160	200	250				
Port size			G 1/2	G 3/4	G 3/4	G 1				
Piston rod diameter		mm	32	40	40	50				
Piston rod thread			M27x2**	M36x2	M36x2	M42x2				
Stroke length		mm	For max. stroke length see load diagram 2.05.002E							
Cushioning			At both ends, infinitely variable							
Cushioning stroke		Cyl.	125	160	200	250				
		mm	42	52	52	52				
Weight (mass) kg										
Mounting	Cylinder-Ø		125		160		200		250	
	*1	*2	1	2	1	2	1	2	1	2
Basic cylinder	7.2	1.3	12.5	2.05	20	2.2	35	4	on request	
A	9.3		16.1		25					
B	8.5		14.9		24					
BA	8.7		15.0		24					
BAS	8.6		14.9		24					
C	8.7		15.0		30					
D	8.7		15.0		30					
EN	10.5		18.3		32					

Series DZ

Ø125 - 250mm

ISO 6431
CETOP RP53P**

DZ 1: Double Acting, Cushions

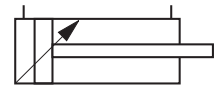

DZ 5: Double Acting, Magnets, Cushions

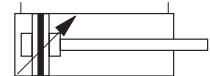

Features:

- Hard-Chrome Plated Rod
- Magnetic Piston
- Adjustable Cushions
- Pre-Lubricated Design

*1 = Weight for cylinder with 100mm stroke
*2 = Weight for every additional 10mm stroke length

DZ Cylinder



Dimensional Data

Basic Cylinder

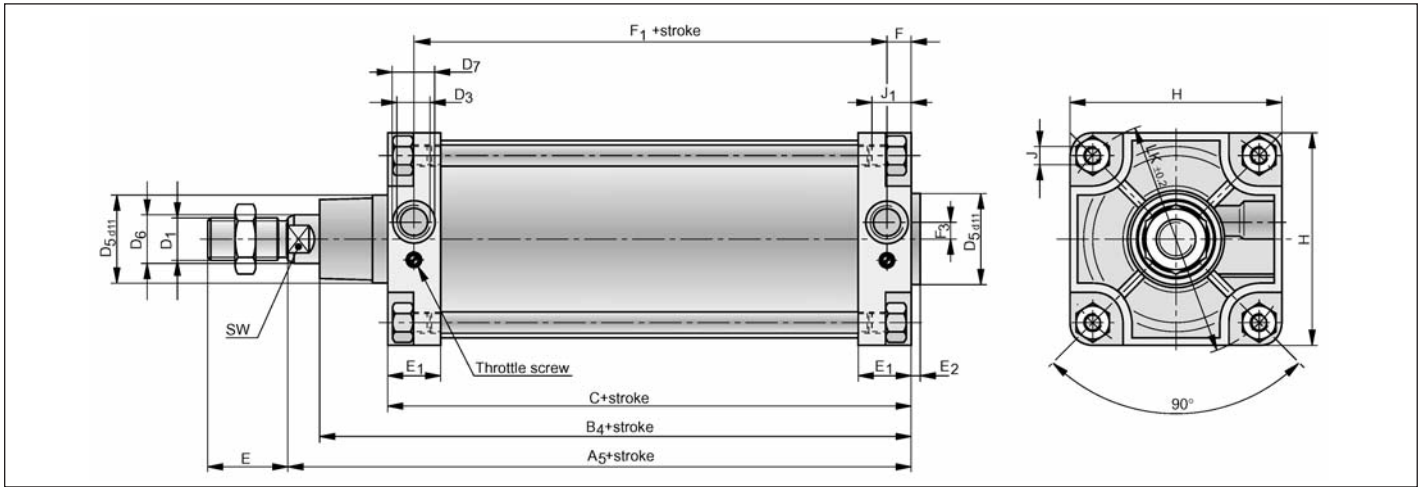

Dimension Table (mm) for Basic Cylinder

Cyl. Ø	A ₅ +stroke	B ₄ +stroke	C+stroke	D ₁	D ₃	ØD ₅	ØD ₆	ØD ₇	E	E ₁	E ₂	F	F ₁ +stroke	F ₃	J	J ₁ max.	H	ØLK	SW
125	225	205	160	M27x2*	G1/2	60	32	28	54	35	6	19	122	11	M12	18	140	156	27
160	260	230	180	M36x2	G3/4	65	40	33	72	45	6	25	130	11	M16	23	180	198	36
200	275	240	180	M36x2	G3/4	75	40	33	72	45	6	25	130	11	M16	23	220	248	36
250	305	270	200	M42x2	G1	90	50	40	84	53	10	32	136	21	M20	27	280	311	48

*Standard piston rod thread M27x2 - on request M24x2 to CETOP RP53P can also be delivered.

Foot Bracket - Type A

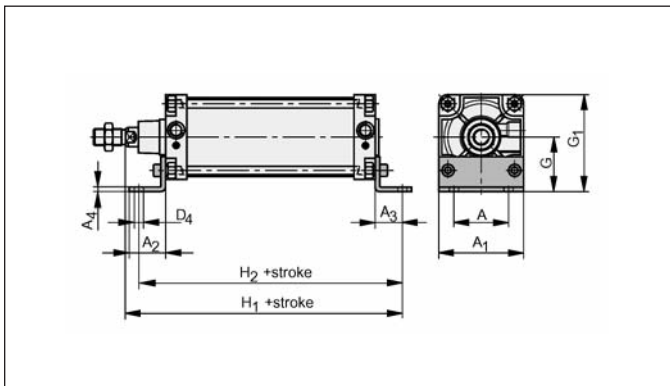

Dimension Table (mm) for Mounting A

Cyl. Ø	A	A ₁	A ₂	A ₃	A ₄	ØD ₄	G	G ₁	H ₁ +stroke	H ₂ +stroke
125	90	140	60	45	8	16	90	160	270	250
160	115	180	80	60	8	18	115	205	320	300
200	135	220	100	70	9	22	135	245	345	320
250	165	280	110	75	12	26	165	305	380	360

Rear Double Clevis - Type B

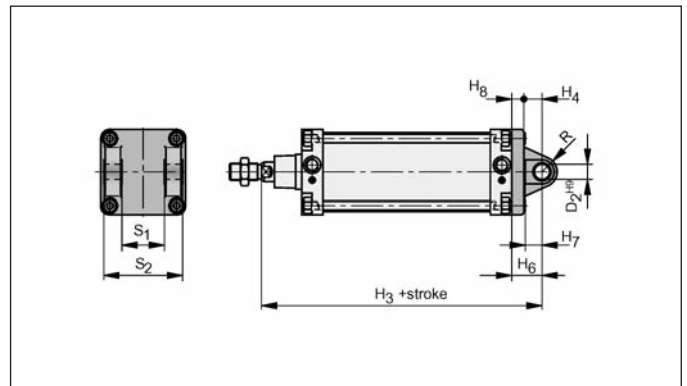

Dimension Table (mm) for Mounting B

Cyl. Ø	D ₂ ^{H9}	H ₃ +stroke	H ₄	H ₆	H ₇	H ₈	R	S ₁	S ₂
125	25	275	30	50	29	20	25	70	130
160	30	315	35	55	34	20	30	90	170
200	30	335	35	60	35	25	31	90	170
250	40	375	45	70	44	25	41	110	200

DZ Cylinder



Cylinder Mounts

Rear Single Clevis - Type BA

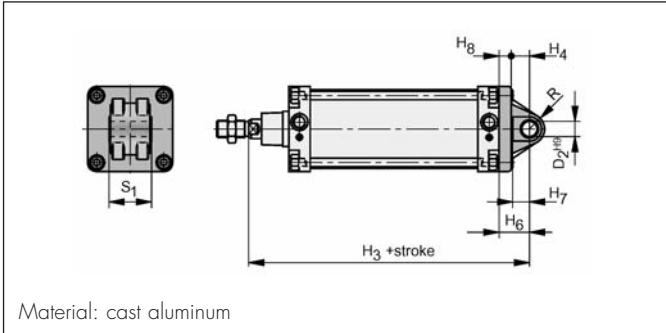

Dimension Table (mm) for Mounting BA

Cyl. Ø	ØD ₂ ^{H9}	H ₃ +stroke	H ₄	H ₆	H ₇	H ₈	R	S ₁
125	25	275	30	50	29	20	25	70
160	30	315	35	55	34	20	30	90
200	30	335	35	60	35	25	31	90
250	40	375	45	70	44	25	41	110

Rear Single Clevis - Type BAS

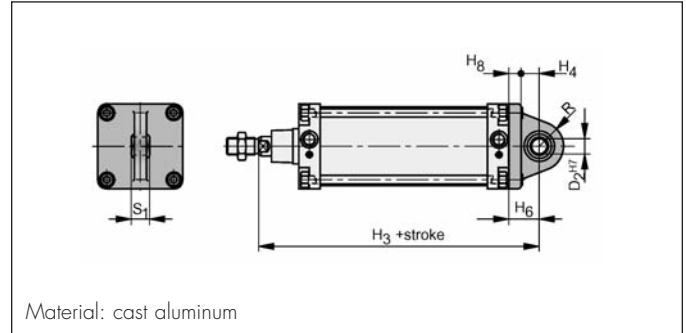

Dimension Table (mm) for Mounting BAS

Cyl. Ø	ØD ₂ ^{H7}	H ₃ +stroke	H ₄	H ₆	H ₈	R	S ₁
125	25	275	30	50	20	40	31
160	30	315	35	55	20	48	37
200	on request						
250	on request						

Front Flange - Type C

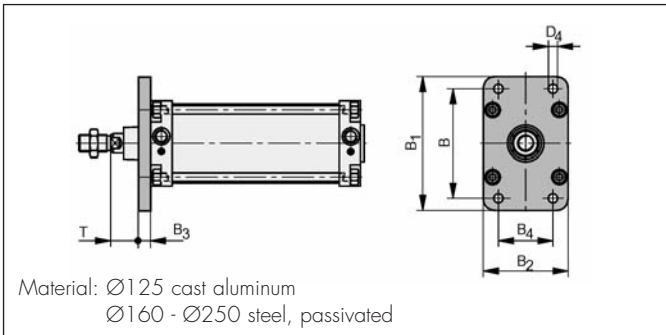

Dimension Table (mm) for Mounting C

Cyl. Ø	B	B ₁	B ₂	B ₃	B ₄	ØD ₄	T
125	180	220	140	20	90	16	45
160	230	280	180	20	115	18	60
200	270	315	220	25	135	22	70
250	330	380	280	25	165	26	80

Rear Flange - Type D

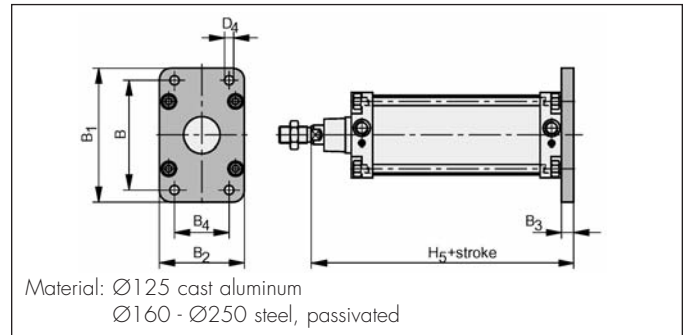

Dimension Table (mm) for Mounting BA

Cyl. Ø	B	B ₁	B ₂	B ₃	B ₄	ØD ₄	H ₅ +stroke
125	180	220	140	20	90	16	245
160	230	280	180	20	115	18	280
200	270	315	220	25	135	22	300
250	330	380	280	25	165	26	330

Adjustable Trunnion - Type EN

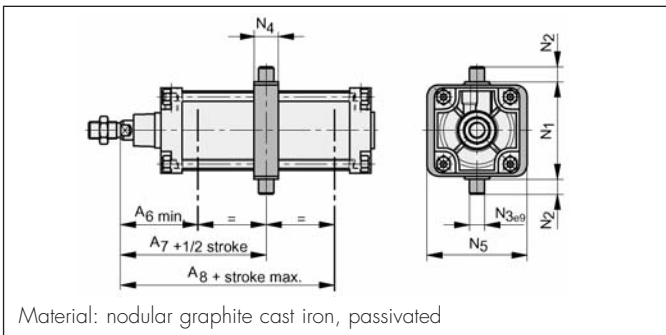

Dimension Table (mm) for Mounting EN

Cyl. Ø	A ₆ min	A ₇ +1/2 stroke	A ₈ +stroke	N ₁	N ₂	N _{3eg}	N ₄	N ₅
125	125	145	165	160	25	25	40	165
160	150	170	190	200	32	32	45	210
200	165	185	205	250	32	32	50	260
250	195	205	210	320	40	40	55	320

Note:
When ordering please give exact dimension A₇.
Mounting is assembled when delivered.

Instructions for mounting EN:

In order to avoid faulty operation of the reed switches, a min. distance of 10 to 20mm has to be kept between switch and EN-mounting when fastening them to the cylinder.

DZ Cylinder



Ordering Information

Basic Cylinder (Without Mounting)					
Series	Symbol	Standard	Bore Ø	Order Instructions	
				Type #	Order #
Double acting with adjustable end cushioning		ISO	125	DZ1125/...	PA 53530-...
		CETOP	125	DZ1125/...	PA 53500-...
		ISO	160	DZ1160/...	PA 54000-...
		ISO	200	DZ1200/...	PA 54500-...
		ISO	250	DZ1250/...	PA 55000-...
Double acting with adjustable end cushioning, for contactless position sensing		ISO	125	DZ5125/...	PA 53540-...
		CETOP	125	DZ5125/...	PA 53510-...
		ISO	160	DZ5160/...	PA 54010-...
		ISO	200	DZ5200/...	PA 54510-...
		ISO	250	DZ5250/...	PA 55010-...

Complete type designation and order no. with stroke length in mm (4 digits)

Standard stroke length: 0025, 0050, 0080, 0100, 0125, 0160, 0200, 0250, 0320, 0400, 0500

Cylinder with Mounting EN					
Series	Symbol	Standard	Bore Ø	Order Instructions	
				Type #	Order #
Double acting with adjustable end cushioning		ISO	125	DZ1125EN/.../...	PA 53536-...
		CETOP	125	DZ1125EN/.../...	PA 53506-...
		ISO	160	DZ1160EN/.../...	PA 54006-.../...
		ISO	200	DZ1200EN/.../...	PA 54506-.../...
		ISO	250	DZ1250EN/.../...	PA 55006-.../...
Double acting with adjustable end cushioning, for contactless position sensing		ISO	125	DZ5125EN/.../...	PA 53546-.../...
		CETOP	125	DZ5125EN/.../...	PA 53516-.../...
		ISO	160	DZ5160EN/.../...	PA 54016-.../...
		ISO	200	DZ5200EN/.../...	PA 54516-.../...
		ISO	250	DZ5250EN/.../...	PA 55016-.../...

Complete type designation and order no. with stroke length in mm (3 digits)

Give dimension A₇ with type designation and order no.

Description	Order #			
	Ø125	Ø160	Ø200	Ø250
Foot Bracket - Type A	PD 22026	PD 22027	PD 24792	PD 25758
Rear Double Clevis - Type B	PD 22034	PD 22035	PD 24990	PD 25710
Rear Single Clevis - Type BA	PD 23418	PD 22628	PD 24999	PD 25759
Rear Single Clevis - Type BAS	PD 23849	PD 23850	PD 25766	PD 25760
Front Flange - Type C	PD 23409	PD 23410	PD 24924	PD 25761
Rear Flange - Type D	PD 23409	PD 23410	PD 24924	PD 25761
Center Trunnion - Type EN	PD 23591	PD 23592	PD 24923	PD 25762

Proximity Sensors/Brackets: See Page 73

AZV Twin Rod Cylinder



Specifications

Features								
Type	Twin Rod							
Series	AZV							
Configurations	AZV: Double Acting, Double Rod, Magnetic Piston, Cushions AZV 3D: Double Acting, 3 Rods, Magnetic Piston, Cushions AZV 4D: Double Acting, 4 Rods, Magnetic Piston, Cushions							
Construction Materials								
Barrel	Extruded Aluminum, Anodized (10µ)							
End Caps	Die Cast Aluminum							
Piston Rod	Steel Hard Chrome Plated (Optional: Stainless Steel)							
Rod Bearing	Teflon Impregnated Bronze							
Piston	Brass							
Piston Bearing	Fiber Reinforced Nylon							
Captive Cushion Screw	Brass (Optional: Stainless)							
Seals	NBR (Optional: Viton)							
End Cap Screws	Steel, Zinc Plated (Optional: Stainless)							
Tooling Plate	Bore: 32, 40, 50 Steel, Black Oxide Treated Bore: 63, 80, 100 Aluminum, Black Oxide Treated							
Characteristics								
Operating Temperature	Min: -5° F (-20°C) Max: +176 °F (+80°C)							
Operating Pressure	Min: 15 PSI (1 bar) Max: 145 PSI (10 bar)							
Normal Operating Pressure	90 PSI (6 bar)							
Lubrication	Pre-lubricated at factory. If additional lubrication is required, use oil compatible for NBR seal and designed for use in pneumatic systems.							
Media	Filtered and Regulated Compressed Air							
Installation	In any Position							
Weight	See Page 44							
Stroke Length	Up to 20 inches—Longer Contact Factory							
Theoretical Forces	See Technical Information Section							
Load Capacity	See Technical Information Section							
Specifications								
Piston Diameter	RDV 25	32	40	50	63	80	100	
Port Sizes	NPT	--	1/8	1/4	1/4	3/8	3/8	1/2
	Metric (G)	1/8	1/8	1/4	1/4	3/8	3/8	1/2
Rod Diameter								
AZV (RDV) (2 Pcs)	mm	6	8	10	12	16	20	20
AZV 3D (2 Pcs)	mm	--	8	10	12	16	20	20
(1 Pc)	mm	--	12	16	20	20	25	25
AZV 4D (4 Pcs)	mm	--	8	10	12	16	20	20
Cushion Lengths	Inch	0.67	0.78	0.98	0.98	0.98	1.10	1.18
All Cylinders	mm	17	20	25	25	25	28	30

Series AZV

Ø32mm - 100mm

Series RDV

Ø25mm

AZV 5: Double Acting, Double Rod, Magnets, Cushions



AZV3D 5: Double Acting, 3 Rods, Magnets, Cushions



AZV4D 5: Double Acting, 4 Rods, Magnets, Cushions



Features:

- Magnetic Piston
- Adjustable Cushions
- Pre-Lubricated Design
- Inch or Metric Construction

AZV Twin Rod Cylinder



Ordering Information

Example: AZV3D - U5050/10-V
 Twin Rod Cylinder
 Single Set of Twin Rods w/Single Rod
 U.S. Option
 Double Acting, Magnets, Cushions
 50mm Bore
 10" Stroke
 Viton Seals

A Z V 3 D - U 5 0 5 0 / 1 0 - V

Versions:

RDV - Ø 25mm Bore Only (Metric Only)

AZV Series

- AZV - Single Set Twin Rods
- AZV 3D - Single Set Twin Rods with Single Rod
- AZV 4D - Double Set Twin Rods

Design:

- - Metric Construction
- U - US Construction: Inch Stroke, NPT Ports, & UNC Threads

Actuation:

- 5 - Double Acting, Magnets, Cushions
- 1 - Double Acting, Cushions
- 6 - Double Acting, Magnets
- 2 - Double Acting

Options:

- - Standard
- V - Viton
- EN - Trunnion, Adjustable
- R - Ø32 Piston Rods Tapped 10•32
- 3D Version Only
- T - Rod Thread: Ø32 - 5/16•18
 Ø40,50,63 - 7/16•20

Stroke:

INCH:

- any inch increment up to 20" standard
- contact factory for special stroke lengths

MM:

- any mm increment up to 500mm standard
- contact factory for special stroke lengths

Bore:

- 025 - 25mm (nom. 1")
 (Available Only in Metric Construction)
- 032 - 32 mm (nom. 1 1/4")
- 040 - 40 mm (nom. 1 1/2")
- 050 - 50 mm (nom. 2")
- 063 - 63 mm (nom. 2 1/2")
- 080 - 80 mm (nom. 3 1/8")
- 100 - 100 mm (nom. 4")

Proximity Sensors/Brackets: See Page 73

AZV Twin Rod Cylinder



Cylinder Mounts

Body Mounts		25mm	32mm	Bore Ø			80mm	100mm
				40mm	50mm	63mm		
Foot Mounting Type: A-	INCH Metric	-- KK 29.302	4170-0352 PD 27917	4170-0452 PD 27918	4170-0552 PD 28072	4170-0652 PD 28073	4170-0852 PD 28074	4170-1052 PD 28075
Rear Double Clevis Type: B-	INCH Metric	-- --	4172-0351 PD 22704	4172-0451 PD 22705	4172-0551 PD 22706	4172-0651 PD 22707	4172-0851 PD 22708	4172-1051 PD 22709
Rear Single Clevis Type: BA-	INCH Metric	-- KB 28.303	4174-0351 PD 23412	4174-0451 PD 23413	4174-0551 PD 23414	4174-0651 PD 23415	4174-0851 PD 23416	4174-1051 PD 23417
Rear Clevis w/Spherical Bearing Type: BAS-	INCH Metric	-- --	4173-0351 PD 23843	4173-0451 PD 23844	4173-0551 PD 23845	4173-0651 PD 23846	4173-0851 PD 23847	4173-1051 PD 23848
Front Flange Type: CA for AZV 5/3D/4D	INCH Metric	-- --	4175-0351 PD 57042	4175-0451 PD 57043	4175-0551 PD 57044	4175-0651 PD 57045	4175-0851 PD 57046	4175-1051 PD 57047
Rear Flange Type: D	INCH Metric	-- --	4176-0351 PD 23403	4176-0451 PD 23404	4176-0551 PD 23405	4176-0651 PD 23406	4176-0851 PD 23407	4176-1051 PD 23408
Trunnion Type: EN	INCH/mm	--	PD 39195	PD 39196	PD 39197	PD 39198	PD 39199	PD 39200
Trunnion Blocks Type: EL (Pair) (See Page 76)	INCH/mm	--	PD 23381	PD 23382	PD 23382	PD 23383	PD 23383	PD 23384
Pivot Mount (w/o Bolts)	INCH/mm	--	PD 25621	PD 25622	PD 25623	PD 25624	PD 25625	PD 25626

Delivery Information: All mounts are sold separately and are not mounted for shipment, except for the trunnion mount which requires factory installation.

Rod Accessories		25mm	32mm	Bore Ø			80mm	100mm
				40mm	50mm	63mm		
Rod Nut	INCH Metric	-- ZP 3848	ZP-U 1810 ZP 1810	ZP-U 2189 ZP 2189	ZP-U 0178 ZP 0178	ZP-U 0178 ZP 0178	ZP-U 0185 ZP 0185	ZP-U 0185 ZP 0185
Rod Clevis	INCH Metric	-- --	-- KY 6135	-- KY 6136	-- KY 6139	-- KY 6139	-- KY 6141	-- KY 6141
Rod Eye	INCH Metric	-- --	-- KY 6147	-- KY 6148	-- KY 6150	-- KY 6150	-- KY 6151	-- KY 6151
Clevis Pin	INCH/mm	--	KY 6153	KY 6154	KY 6157	KY 6156	KY 6158	KY 6159
Rod Alignment Coupling	INCH Metric	-- --	-- KY 1129	-- KY 1131	-- KY 1133	-- KY 1133	-- KY 1134	-- KY 1134

NOTES:

- * Body Nut for RDV type cylinder
- ** Items in **BOLD** type either include Inch mounting hardware or indicate Inch threads.

Proximity Sensors/Brackets: See Page 73

AZV Twin Rod Cylinder



Weights

AZV

Weight	25mm		32mm		40mm		Bore Ø 50mm		63mm		80mm		100mm		
	1	2	*1	*2	1	2	1	2	1	2	1	2	1	2	
Basic Cylinder	lbs	1.01	0.18	1.76	0.55	2.21	0.77	3.75	1.10	5.73	1.32	9.26	1.98	13.67	2.21
	kg	0.46	0.08	0.8	0.25	1.0	0.35	1.7	0.5	2.6	0.6	4.2	0.9	6.2	1.0
Type A (RA)	lbs	0.22	--	2.21	--	2.76	--	4.41	--	6.62	--	11.03	--	15.66	--
	kg	0.10	--	1.0	--	1.25	--	2.0	--	3.0	--	5.0	--	7.1	--
Type B (RA)	lbs	--	--	1.98	--	2.43	--	4.08	--	6.17	--	10.14	--	14.99	--
	kg	--	--	0.9	--	1.1	--	1.85	--	2.8	--	4.6	--	6.8	--
Type BA	lbs	--	--	2.21	--	2.65	--	4.19	--	6.62	--	11.03	--	16.10	--
	kg	--	--	1.0	--	1.2	--	1.9	--	3.0	--	5.0	--	7.3	--
Type BAS	lbs	--	--	2.09	--	2.65	--	4.19	--	6.39	--	10.36	--	15.44	--
	kg	--	--	0.95	--	1.2	--	1.9	--	2.9	--	4.7	--	7.0	--
Type D	lbs	--	--	1.98	--	2.43	--	4.08	--	6.28	--	10.36	--	15.44	--
	kg	--	--	0.9	--	1.1	--	1.85	--	2.85	--	4.7	--	7.0	--
Type EN	lbs	--	--	2.65	--	3.75	--	5.73	--	8.60	--	13.23	--	19.18	--
	kg	--	--	1.2	--	1.7	--	2.6	--	3.90	--	6.0	--	8.7	--

*1 = Weight for cylinder with 4" (100 mm) stroke

*2 = Weight for every additional 4" (100 mm) stroke length

AZV 3D

Weight	32mm		40mm		Bore Ø 50mm		63mm		80mm		100mm		
	*1	*2	1	2	1	2	1	2	1	2	1	2	
Basic Cylinder	lbs	2.21	0.66	3.31	0.99	5.51	1.54	7.06	1.87	11.69	2.87	16.54	3.31
	kg	1.0	0.30	1.5	0.45	2.5	0.7	3.2	0.85	5.3	1.3	7.5	1.5
Type A	lbs	2.65	--	3.97	--	6.17	--	8.38	--	13.23	--	18.74	--
	kg	1.2	--	1.8	--	2.8	--	3.8	--	6.0	--	8.5	--
Type C	lbs	2.43	--	3.53	--	5.84	--	7.61	--	12.79	--	18.08	--
	kg	1.1	--	1.6	--	2.65	--	3.45	--	5.8	--	8.2	--
Type EN	lbs	3.09	--	4.85	--	7.5	--	9.92	--	15.88	--	22.05	--
	kg	1.4	--	2.2	--	3.4	--	4.5	--	7.2	--	10.0	--

*1 = Weight for cylinder with 4" (100 mm) stroke

*2 = Weight for every additional 4" (100 mm) stroke length

AZV 4D

Weight	32mm		40mm		Bore Ø 50mm		63mm		80mm		100mm		
	*1	*2	1	2	1	2	1	2	1	2	1	2	
Basic Cylinder	lbs	2.21	0.66	3.09	0.88	5.07	1.32	7.06	1.98	12.35	3.09	16.32	3.31
	kg	1.0	0.30	1.4	0.40	2.3	0.6	3.2	0.9	5.6	1.4	7.4	1.50
Type A	lbs	2.65	--	3.75	--	5.73	--	7.94	--	13.89	--	18.30	--
	kg	1.2	--	1.70	--	2.6	--	3.6	--	6.3	--	8.3	--
Type EN	lbs	3.09	--	4.63	--	7.06	--	9.92	--	16.54	--	22.05	--
	kg	1.4	--	2.1	--	3.2	--	4.5	--	7.5	--	10.0	--

AZV Twin Rod Cylinder



Dimensional Data

Basic Cylinder

RDV 5025/xxxx

(xxxx= Stroke Length)

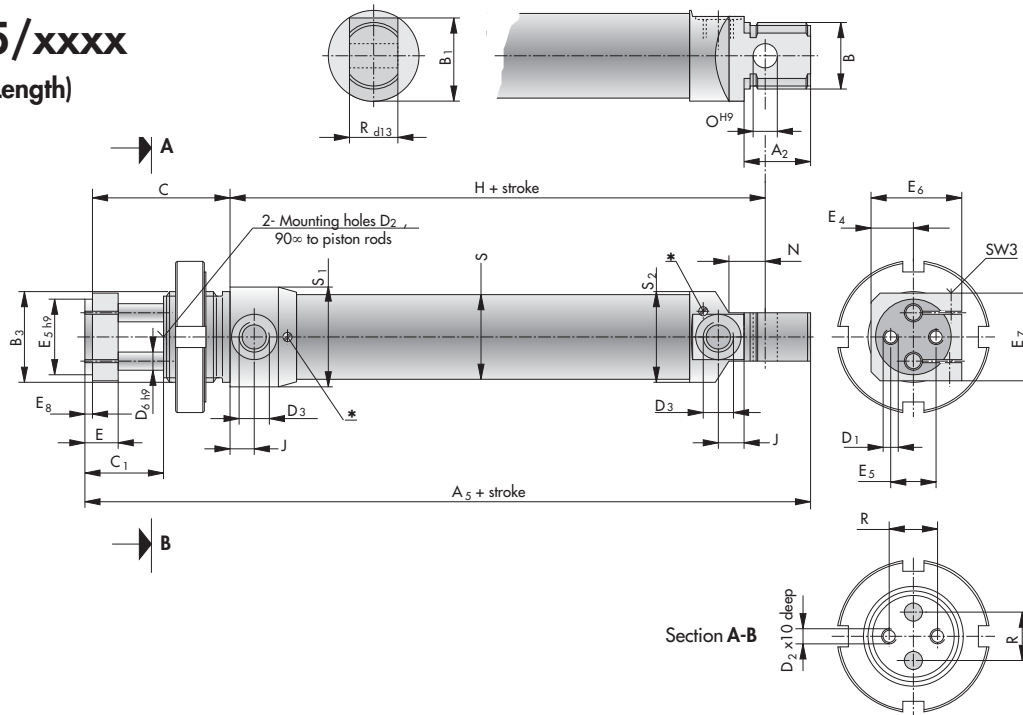

A2	A5+ stroke	B	B1	B3	C	D1	D3 h9	øD6	E	E4 h9	øE5	E6
0.87 22	6.16 156.5	-- M22 x 1.5	1.1 28	-- M30x1.5	1.81 46	-- M5	-- G1/8	0.24 6	0.43 11	0.59 15	0.98 25	1.14 29
E7	E8	F3 stroke	H+ stroke	N H9	øO	øS	øS1 d13	øS2 d13	R	SW	*	
1.18 30	0.08 2	0.31 8	3.76 95.5	0.47 12	0.31 8	1.1 28	1.3 33	1.18 30	0.63 16	M3	M8x.75	

Foot Mount - Type RA

Rear Clevis - Type RB

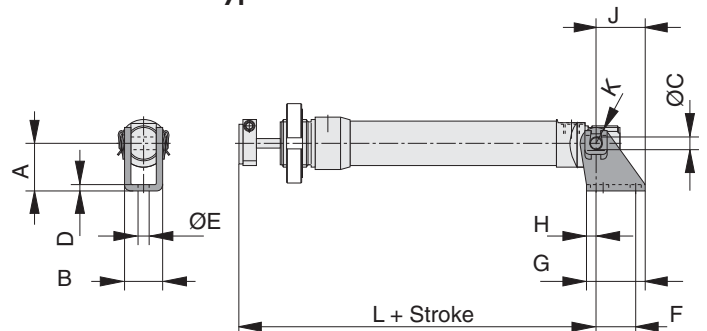
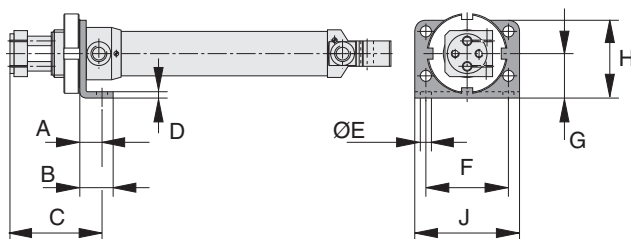

	A	B	C	D	E	F	G	H	J	K	L+
RA	.55 14	.83 21	2.20 56	0.16 4	0.26 6.6	2.05 52	1.10 28	1.93 49	2.60 66		
RB	1.18 30	0.63 16.1	0.31 8	0.16 4	0.26 6.6	0.98 25	1.46 37	0.24 6	1.14 29	0.39 10	5.65 143.5

Dimensions: Bold Type= INCH, Standard= mm

AZV Twin Rod Cylinder



Dimensional Data

AZV Ø32-100mm

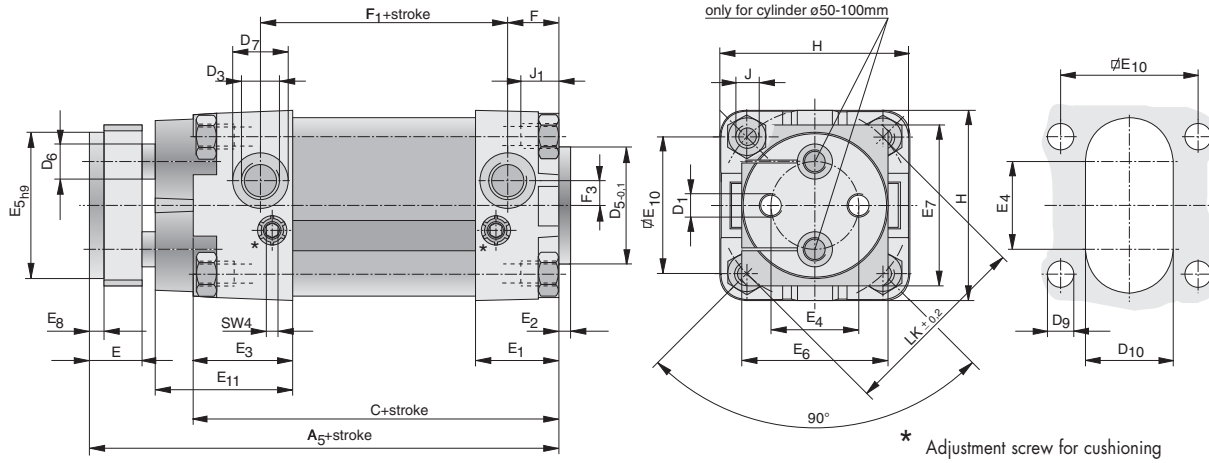

AZV 3D Ø32-100mm

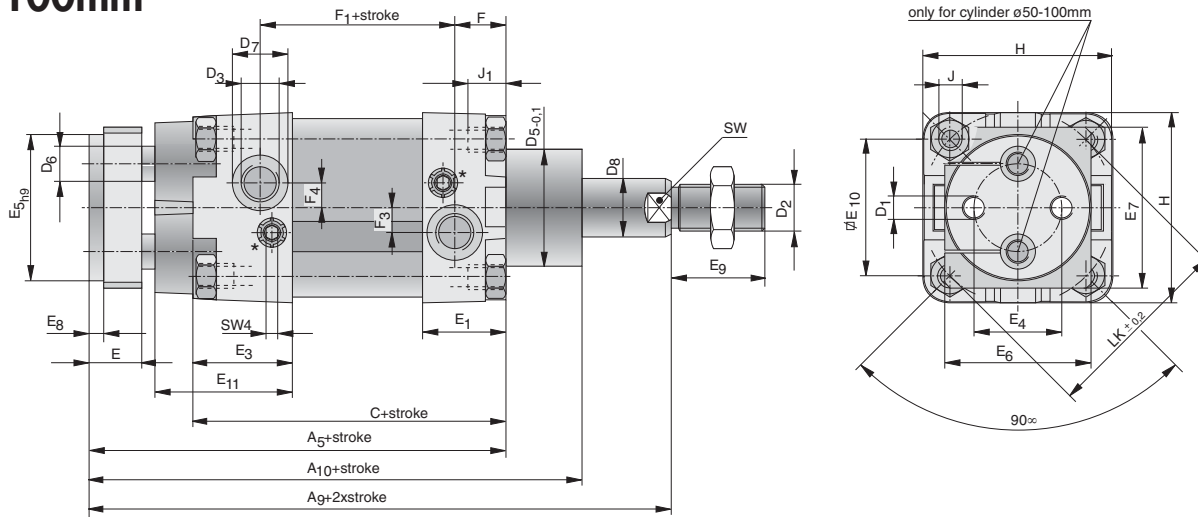

AZV 4D Ø32-100mm

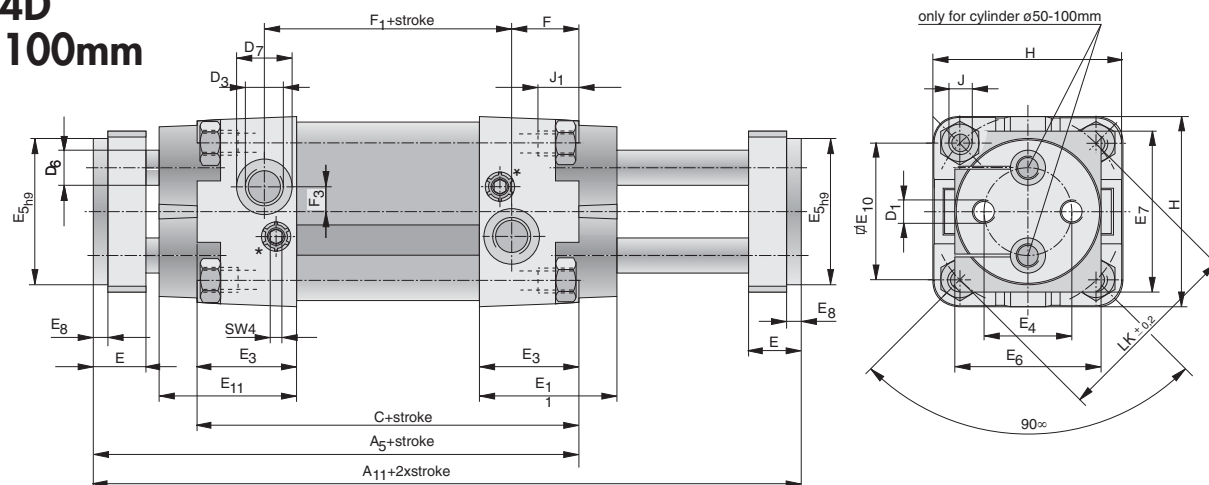

AZV Twin Rod Cylinder



Dimensional Data

Bore Ø	A ₅ + Stroke	A ₉ + Stroke	A ₁₀ + Stroke	A ₁₁ + Stroke	C+ Stroke	D ₁	D ₂	D ₃	ØD ₅	ØD ₆	ØD ₇
32	5.04 128	6.06 154	5.75 146	6.06 154	4.02 102	1/4•20 M 6	3/8 •24 M10x1.25	1/8 NPT G 1/8	1.18 30	0.31 8	0.59 15
40	5.59 142	6.77 172	6.42 163	6.77 172	4.41 112	5/16•18 M 8	7/16 •20 M12x1.25	1/4 NPT G 1/4	1.38 35	0.39 10	0.75 19
50	5.94 151	7.40 188	6.97 177	7.28 185	4.61 117	5/16•18 M 8	5/8 •18 M16x1.5	1/4 NPT G 1/4	1.57 40	0.47 12	0.75 19
63	6.34 161	7.80 198	7.36 187	7.76 197	4.92 125	3/8•16 M 10	5/8 •18 M16x1.5	3/8 NPT G 3/8	1.77 45	0.63 16	0.91 23
80	6.85 174	8.66 220	8.11 206	8.35 212	5.35 136	1/2•13 M 12	3/4•16 M20x1.5	3/8 NPT G 3/8	1.77 45	0.79 20	0.91 23
100	7.13 181	9.13 232	8.58 218	8.62 219	5.63 143	1/2•13 M 12	3/4•16 M20x1.5	1/2 NPT G 1/2	2.17 55	0.79 20	1.1 28
Bore Ø	D ₈	D ₁₀	E	E ₁	E ₂	E ₃	ØE ₄	E ₅ h ₉	E ₆	E ₇	E ₈
32	0.47 12	0.91 23	0.59 15	1.14 29	0.20 5	1.02 26	0.75 19	1.26 32	1.26 32	1.57 40	0.16 4
40	0.63 16	0.98 25	0.59 15	1.06 27	0.20 5	1.18 30	0.89 22.5	1.57 40	1.57 40	1.77 45	0.16 4
50	0.79 20	1.18 30	0.71 18	1.14 29	0.26 6.5	1.34 34	1.18 30	1.97 50	1.97 50	2.17 55	0.2 5
63	0.79 20	1.34 34	0.87 22	1.18 30	0.24 6	1.34 34	1.5 38	2.48 63	2.48 63	2.76 70	0.2 5
80	0.98 25	1.5 38	0.87 22	1.34 34	0.32 8	1.54 39	1.97 50	3.15 80	3.15 80	3.74 95	0.2 5
100	0.98 25	1.5 38	0.87 22	1.38 35	0.32 8	1.57 40	2.76 70	3.94 100	3.94 100	4.53 115	0.2 5
Bore Ø	E ₁₁	F	F ₁ + Stroke	F ₂ + Stroke	F ₃	F ₄	J	J ₁ max	H	ØLK	SW
32	1.34 34	0.57 14.5	2.91 74	2.95 75	0.24 6	0.22 5.5	1/4•20 M 6	0.43 11	1.85 47	1.81 46	10
40	1.65 42	0.63 16	3.05 77.5	2.95 75	0.28 7	0.26 6.5	1/4•20 M 6	0.43 11	2.09 53	2.13 54	14
50	1.85 47	0.69 17.5	3.03 77	2.83 72	0.37 9.5	0.33 8.5	5/16•18 M 8	0.47 12	2.56 65	2.6 66	17
63	1.77 45	0.69 17.5	3.43 87	3.27 83	0.39 10	0.31 8	5/16•18 M 8	0.47 12	2.95 75	3.15 80	17
80	2.05 52	0.81 20.5	3.54 90	3.35 85	0.35 9	0.35 9	3/8•16 M 10	0.63 16	3.74 95	4.02 102	22
100	2.09 53	0.75 19	3.94 100	3.74 95	0.51 13	0.51 13	3/8•16 M 10	0.63 16	4.53 115	4.96 126	22

Tolerance Chart

Bore Ø	h ₉	
	Inch	mm
32	0	0
40	-0.002	-0.062
50	-0.002	-0.062
63	-0.003	-0.074
80	-0.003	-0.074
100	-0.003	-0.087

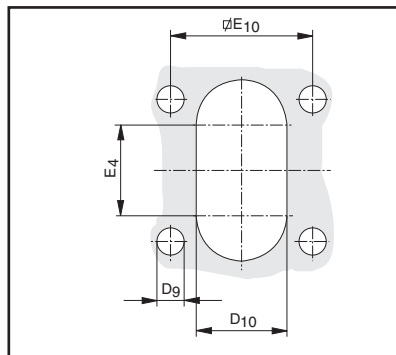

Dimensions for Front Mounted Installations

Bore Ø	D ₉	D ₁₀	E ₄	E ₁₀
32	0.28 7	0.91 23	0.75 19	1.28 32.5
40	0.28 7	0.98 25	0.89 22.5	1.52 38.5
50	0.35 9	1.18 30	1.18 30	1.83 46.6
63	0.35 9	1.34 34	1.50 38	2.23 56.6
80	0.39 10	1.50 38	1.97 50	2.84 72.1
100	0.39 10	1.50 38	2.76 70	3.50 89

AZV Twin Rod Cylinder



Cylinder Mounts

Foot Bracket - Type A

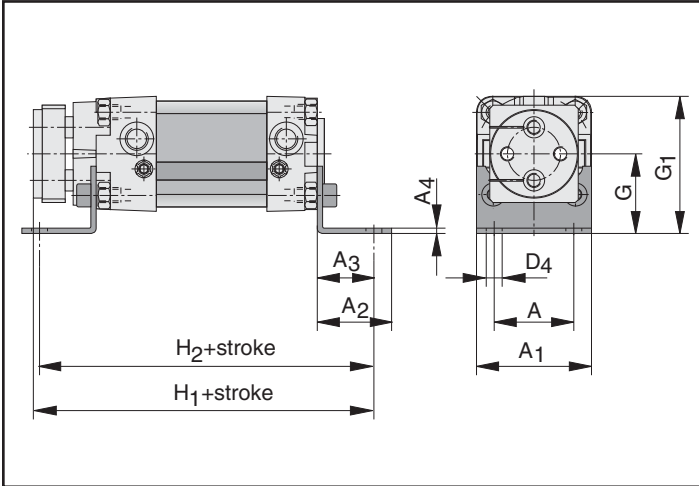

Rear Double Clevis - Type B

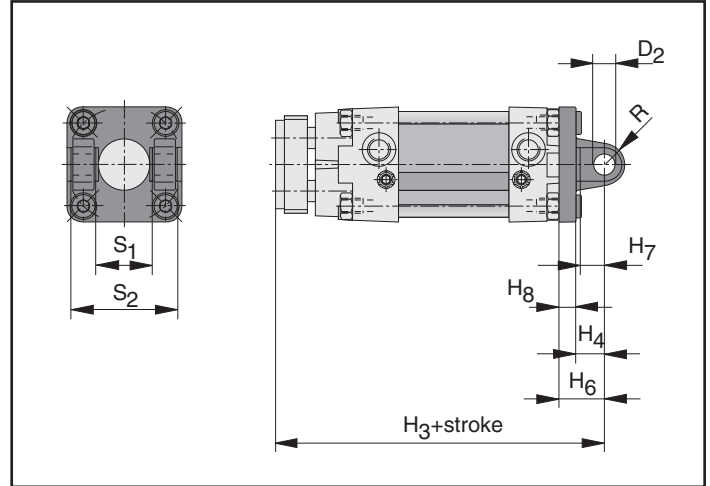

Rear Single Clevis - Type BA

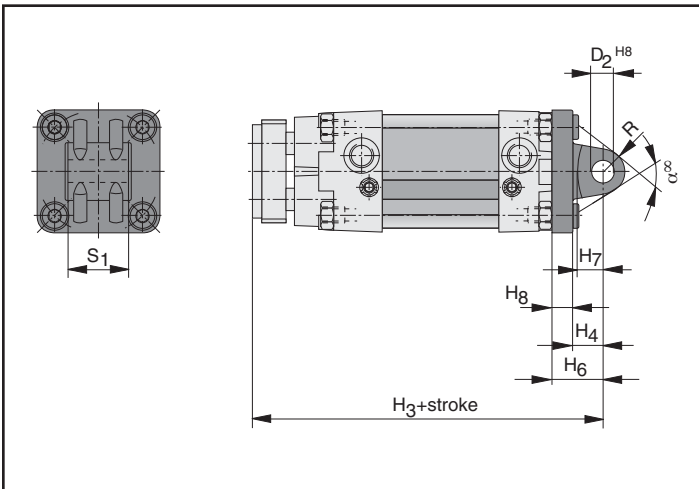

Rear Single Clevis with Spherical Bearing - Type BAS

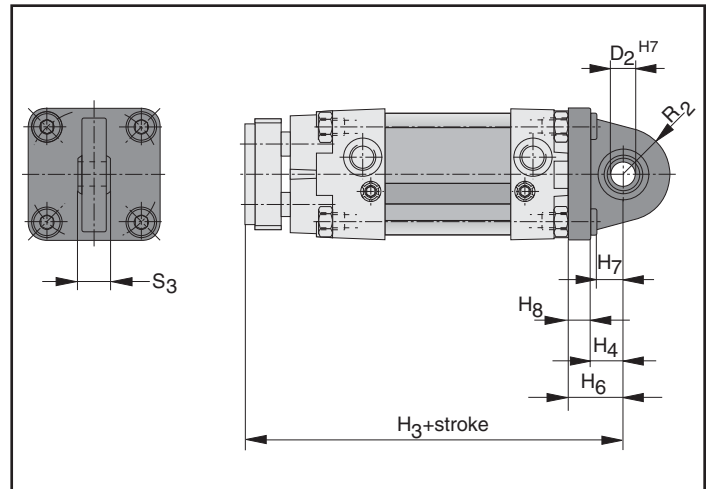

Rear Flange - Type D

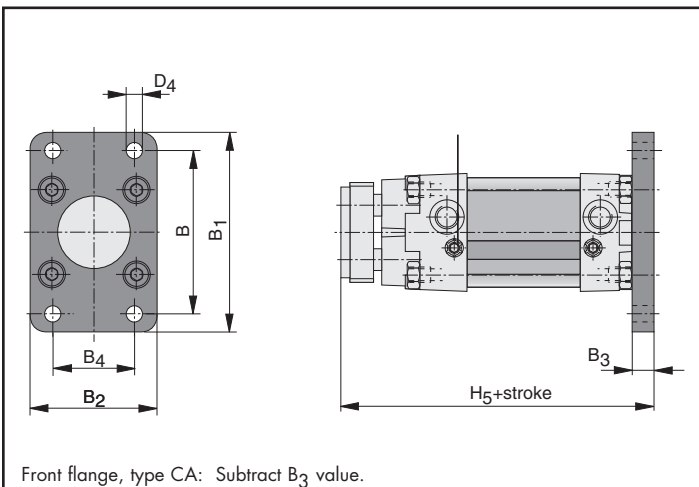

Adjustable Trunnion - Type EN

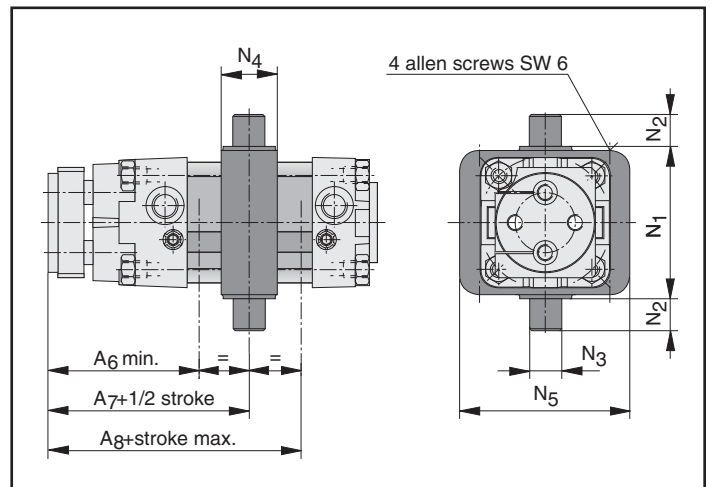

AZV Twin Rod Cylinder



Cylinder Mounts

Bore Ø	A	A ₁	A ₂	A ₃	A ₄	A ₆ min	A ₇ + 1/2 Stroke	A ₈ max + Stroke	α°	B	B ₁	B ₂
32	1.26	1.85	1.26	0.94	0.12	2.52	2.99	3.43	2.36	2.52	3.11	1.97
	32	47	32	24	3	64	76	87	60	64	79	50
40	1.42	2.09	1.5	1.1	0.12	2.95	3.43	3.9	2.36	2.83	3.54	2.20
	36	53	38	28	3	75	87	99	60	72	90	56
50	1.77	2.56	1.65	1.26	0.12	3.31	3.74	4.17	2.76	3.54	4.33	2.76
	45	65	42	32	3	84	95	106	70	90	110	70
63	1.97	2.95	1.65	1.26	0.12	3.5	3.98	4.41	2.36	3.94	4.72	3.03
	50	75	42	32	3	89	101	112	60	100	120	77
80	2.48	3.74	2.17	1.61	0.16	3.78	4.29	4.76	2.76	4.96	6.02	3.94
	63	95	55	41	4	96	109	121	70	126	153	100
100	2.95	4.53	2.2	1.61	0.16	3.9	4.41	4.92	2.76	5.91	7.01	4.72
	75	115	56	41	4	99	112	125	70	150	178	120

Bore Ø	B ₃	B ₄	ØD ₂	ØD ₄	G	G ₁	H ₁ + Stroke	H ₂ + Stroke	H ₃ + Stroke	H ₄	H ₅ + Stroke	H ₆
32	0.39	1.26	0.39	0.28	1.26	2.19	5.98	5.91	5.91	0.47	5.43	0.87
	10	32	10	7	32	55.5	152	150	150	12	138	22
40	0.39	1.42	0.47	0.35	1.42	2.46	6.69	6.61	6.57	0.59	5.98	0.98
	10	36	12	9	36	62.5	170	168	167	15	152	25
50	0.47	1.77	0.47	0.35	1.77	3.05	7.2	7.13	7.01	0.63	6.42	1.06
	12	45	12	9	45	77.5	183	181	178	16	163	27
63	0.47	1.97	0.63	0.35	1.97	3.44	7.6	7.44	7.6	0.83	6.81	1.26
	12	50	16	9	50	87.5	193	189	193	21	173	32
80	0.63	2.48	0.63	0.47	2.48	4.35	8.46	8.58	8.27	0.83	7.48	1.42
	16	63	16	12	63	110.5	215	218	210	21	190	36
100	0.63	2.95	0.79	0.55	2.8	5.06	8.74	8.86	8.74	0.98	7.76	1.61
	16	75	20	14	71	128.5	222	225	222	25	197	41

Bore Ø	H ₇	H ₈	N ₁	N ₂	N ₃ e9	N ₄	N ₅	R	R ₂	S ₁	S ₂	S ₃	T+ Stroke
32	0.43	0.39	1.97	0.47	0.47	0.99	2.56	0.41	0.71	1.02	1.77	0.55	0.63
	11	10	50	12	12	25	65	10.5	18	26	45	14	16
40	0.55	0.39	2.48	0.63	0.63	1.18	2.76	0.51	0.83	1.1	2.05	0.63	0.79
	14	10	63	16	16	30	70	13	21	28	52	16	20
50	0.59	0.43	2.95	0.63	0.63	1.18	3.54	0.51	0.91	1.26	2.36	0.63	0.98
	15	11	75	16	16	30	90	13	23	32	60	16	25
63	0.79	0.43	3.54	0.79	0.79	1.57	3.94	0.67	1.06	1.57	2.76	0.83	0.98
	20	11	90	20	20	40	100	17	27	40	70	21	25
80	0.83	0.59	4.33	0.79	0.79	1.77	5.51	0.67	1.14	1.97	3.54	0.83	1.18
	21	15	110	20	20	45	140	17	29	50	90	21	30
100	0.94	0.63	5.2	0.98	0.98	1.97	5.94	0.83	1.34	2.36	4.33	0.98	1.38
	24	16	132	25	25	50	151	21	34	60	110	25	35

Tolerance Chart

Bore Ø	e9		H ₇		H ₈	
	Inch	mm	Inch	mm	Inch	mm
32	-0.001	-0.032	+0.001	+0.018	+0.001	+0.027
	-0.003	-0.075	0	0	0	0
40	-0.001	-0.032	+0.001	+0.018	+0.001	+0.027
	-0.003	-0.075	0	0	0	0
50	-0.001	-0.032	+0.001	+0.018	+0.001	+0.027
	-0.003	-0.075	0	0	0	0
63	-0.002	-0.040	+0.001	+0.018	+0.001	+0.027
	-0.004	-0.092	0	0	0	0
80	-0.002	-0.040	+0.001	+0.018	+0.001	+0.027
	-0.004	-0.092	0	0	0	0
100	-0.002	-0.040	+0.001	+0.021	+0.001	+0.033
	-0.004	-0.092	0	0	0	0

Dimensions: Bold Type: INCH, Standard: mm

DZB Blocking Cylinder



Specifications

Features	
Type	Blocking Cylinder
Series	DZB
Configurations	DZB Double Acting, Retract Lock, Magnetic Piston, Cushions Rear DZBA Double Acting, Extend Lock, Magnetic Piston, Cushions Rear
Construction Materials	
Barrel	Aluminum, Anodized (10µ)
Front End Cap	Machined Aluminum, Anodized (10µ)
Rear End Cap	Die-Cast Aluminum
Piston Rod	Case Hardened Steel, Hard Chrome Plated
Rod Bearing	Teflon Impregnated Brass
Piston	Molded NBR, (Optional: Viton)
Seals	NBR (Optional: Viton)
Tie Rod Nuts	Steel, Zinc Plated
Tie Rods	Steel, Zinc Plated
Characteristics	
Operating Temperature	NBR: -5°F (-20°C) to +176°F (+80°C)
Operating Pressure	30 PSI (2 bar) to 120 PSI (8 bar)
Normal Operating Pressure	90 PSI (6 bar)
Lock Release Pressure	≥ 60 PSI (4 Bar)
Lubrication	Pre-lubricated at factory. If additional lubrication is required use oil compatible with NBR seals and designed for use in pneumatic systems.
Media	Filtered and Regulated Compressed Air
Installation	In any Position
Weight	See Page 48
Stroke Length	Up to 20 inches—Longer Lengths Contact Factory
Theoretical Forces	See Technical Information Section
Load Holding Capacity	Equal to the Potential Thrust in Direction of Lock
Specifications	
Piston Diameter	32 40 50 63 80 100 125
Port Sizes Metric (G)	1/8 1/4 1/4 3/8 1/2 1/2 1/2
Control Port Metric (G)	M5 1/8 1/8 1/4 1/4 1/4 1/4
Rod Diameter DZB mm	12 16 20 20 25 25 32
Cushion Length (Rear Only) mm	20 25 25 25 28 30 42

Series DZB & DZBA

Ø32mm - 125mm

DZB: Double Acting, Retract Lock, Magnets, Cushions

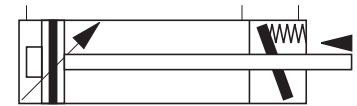

DZBA: Double Acting, Extend Lock, Magnets, Cushions

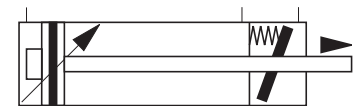

Features:

- Retract Rod Lock Control**
- Extend Rod Lock Control**
- Magnetic Piston**
- Adjustable Rear Cushion**
- Pre-Lubricated Design**
- Inch or Metric Construction**

DZB Blocking Cylinder



Ordering Information

Example: DZBA 5050/20-V
 Blocking Cylinder
 Extended Lock
 Double Acting, Magnets, Cushions
 50mm Bore
 20mm Stroke
 Viton Seals

D Z B A - 5 0 5 0 / 2 0 - V

Versions:

- DZB — Retract Lock Control
- DZBA — Extend Lock Control

Actuation:

- 5 — Double Acting, Magnets, Rear Cushions

Options:

- — Standard
- V — Viton
- EN — Trunnion

Stroke:

- MM: (standard)
- any mm increment up to 500mm standard
- contact factory for special stroke lengths

Bore:

- 032 — 32mm (nom. 1-1/4")
- 040 — 40mm (nom. 1-1/2")
- 050 — 50mm (nom. 2")
- 063 — 63mm (nom. 2-1/2")
- 080 — 80mm (nom. 3-1/8")
- 100 — 100mm (nom. 4")
- 125 — 125mm (nom. 5")

Proximity Sensors/Brackets: See Page 73

Weights

Bore Ø		32mm		40mm		50mm		63mm		80mm		100mm		125mm	
		*1	*2	*1	*2	*1	*2	*1	*2	*1	*2	*1	*2	*1	*2
Basic Cylinder	lbs.	2.34	0.14	3.20	0.31	5.40	0.37	8.16	0.41	13.23	0.64	20.95	0.77	26.24	0.72
	kg	1.06	0.26	1.45	0.56	2.45	0.67	3.70	0.75	6.00	1.15	9.50	1.40	11.90	1.30
Mount Types:															
Type B	lbs	2.56		3.42		5.51		8.60		14.11		22.27		29.11	
	kg	1.16		1.55		2.50		3.90		6.40		10.10		13.20	
Type BA	lbs	2.78		3.64		5.62		9.04		14.99		23.37		29.55	
	kg	1.26		1.65		2.55		4.10		6.80		10.60		13.30	
Type BAS	lbs	2.67		3.64		5.62		8.82		14.33		22.71		29.33	
	kg	1.21		1.65		2.55		4.00		6.50		10.30		13.40	
Type D	lbs	2.67		3.42		5.51		8.71		14.33		22.71		29.55	
	kg	1.21		1.55		2.50		3.95		6.50		10.30		13.40	
Type EN	lbs	3.22		4.74		7.17		11.03		17.20		26.68		33.52	
	kg	1.46		2.15		3.25		5.00		7.80		12.10		15.20	

*1 = Weight for cylinder with 4" (100 mm) stroke
 *2 = Weight for every additional 4" (100 mm) stroke length.

DZB Blocking Cylinder



Cylinder Accessories

Body Mounts	32mm	40mm	50mm	Bore Ø 63mm	80mm	100mm	125mm
Foot Mounting Type: A-	PD 27917	PD 27918	PD 28072	PD 28073	PD 28074	PD 28075	PD 22026
Rear Double Clevis Type: B-	PD 22704	PD 22705	PD 22706	PD 22707	PD 22708	PD 22709	PD 22034
Rear Single Clevis Type: BA-	PD 23412	PD 23413	PD 23414	PD 23415	PD 23416	PD 23417	PD 23418
Rear Clevis w/Spherical Bearing Type: BAS-	PD 23843	PD 23844	PD 23845	PD 23846	PD 23847	PD 23848	PD 23849
Front Flange Type: C	PD 23403	PD 23404	PD 23405	PD 23406	PD 23407	PD 23408	PD 23409
Rear Flange Type: D	PD 23403	PD 23404	PD 23405	PD 23406	PD 23407	PD 23408	PD 23409
Trunnion Type: EN	PD 24039	PD 24040	PD 24041	PD 24042	PD 24043	PD 24044	--
Trunnion Blocks (Pair)	PD 23381	PD 23382	PD 23382	PD 23383	PD 23383	PD 23384	PD 23384
Pivot Mount (w/o Bolts)	PD 40844	PD 40845	PD 40846	PD 40847	PD 40848	PD 40849	

Delivery information: Mounts are sold separately and shipped detached from the cylinder with the exception of the Trunnion Mount which must be attached to the cylinder during the assembly process.

Rod Accessories	32mm	40mm	50mm	Bore Ø 63mm	80mm	100mm	125mm
Rod/Body Nut	ZP 1810	ZP 2189	ZP 0178	ZP 0178	ZP 0185	ZP 0185	ZP 2190 (M24x2) ZP 2039 (M27x2)
Rod Clevis	KY 6135	KY 6136	KY 6139	KY 6139	KY 6141	KY 6141	KY 6142 (M24x2) KY 6866 (M27x2)
Rod Eye w/Bearing	KY 6147	KY 6148	KY 6150	KY 6150	KY 6151	KY 6151	KY 6152 (M24x2) KY 6862 (M27x2)
Clevis Pin	KY 6153	KY 6154	KY 6157	KY 6156	KY 6158	KY 6159	PD 22598
Rod Alignment Coupling	KY 1129	KY 1131	KY 1133	KY 1133	KY 1134	KY 1134	--

DZB Blocking Cylinder



Dimensional Data

DZB Ø32-125mm

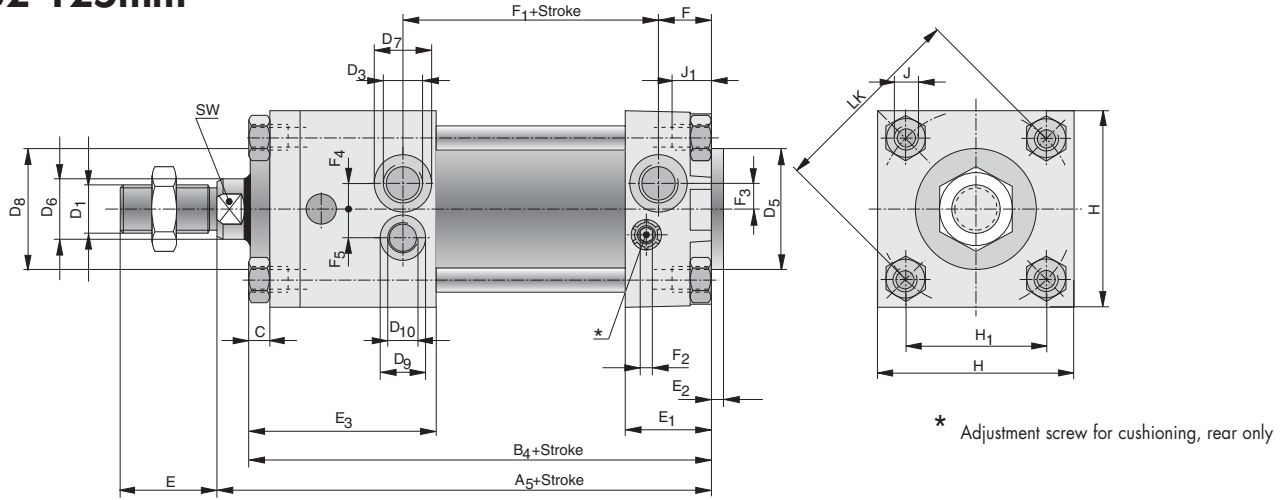

DZBA Ø32-125mm

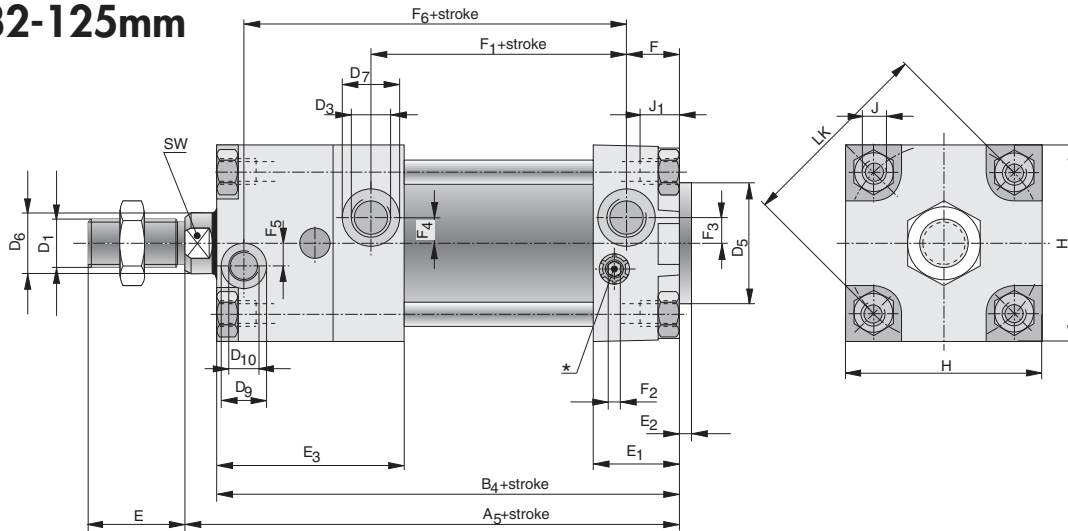

NOTE:

- D3 Cylinder Port
- D10 Lock Control Port

DZB Blocking Cylinder



Dimensional Data

Bore Ø		A ₅ +	B ₄ + Stroke	C Stroke	D ₁	D ₃	Ø D ₅	Ø D ₆	Ø D ₇	Ø D ₈
32	ISO**	4.72 120	4.41 112	0.2 5	3/8•24 M 10x1.25	NPT 1/8 G1/8	1.18 30	0.47 12	0.59 15	1.18 30
40	ISO**	5.31 135	4.96 126	0.24 6	1/2•20 M 12x1.25	NPT 1/4 G1/4	1.38 35	0.63 16	0.75 19	1.38 35
50	ISO**	5.63 143	5.2 132	0.26 6.5	5/8•18 M 16x1.5	NPT 1/4 G1/4	1.57 40	0.79 20	0.75 19	1.57 40
63	*	6.69 170	6.26 159	0.26 6.5	5/8•18 M 16x1.5	NPT 3/8 G3/8	1.77 45	0.79 20	0.91 23	2.24 57
80	*	7.4 188	6.85 174	0.33 8.5	3/4•16 M 20x1.5	NPT 3/8 G3/8	1.77 45	0.98 25	0.91 23	3.07 78
100	*	7.99 203	7.44 189	0.33 8.5	3/4•16 M 20x1.5	NPT 1/2 G1/2	2.17 55	0.98 25	1.1 28	3.94 100
125	ISO**	10.04 255	8.23 209	0.59 15	1•14 M 27x2	NPT 1/2 G1/2	2.36 60	1.26 32	1.1 28	4.76 121
125	CETOP**	10.04 255	8.23 209	0.59 15	1•14 M 24x2	NPT 1/2 G1/2	2.36 60	1.26 32	1.1 28	4.76 121

Bore Ø	Ø D ₉	D ₁₀	E	E ₁	E ₂	E ₃	F	F ₁ +	F ₂ Stroke	F ₃
32	0.31 8	10 • 32 M 5	0.79 20	1.14 29	0.16 4	1.81 46	0.55 14	2.36 60	SW 4	0.22 5.5
40	0.59 15	NPT 1/8 G1/8	0.94 24	1.06 27	0.16 4	2.22 56.5	0.63 16	2.5 63.5	SW 4	0.28 7
50	0.59 15	NPT 1/8 G1/8	1.26 32	1.14 29	0.16 4	2.4 61	0.69 17.5	2.54 64.5	SW 4	0.33 8.5
63	0.75 19	NPT 1/4 G1/4	1.26 32	1.18 30	0.16 4	3.19 81	0.67 17	2.87 73	SW 4	0.31 8
80	0.75 19	NPT 1/4 G1/4	1.57 40	1.34 34	0.16 4	3.31 84	0.81 20.5	3.25 82.5	SW 4	0.35 9
100	0.75 19	NPT 1/4 G1/4	1.57 40	1.38 35	0.16 4	3.64 92.5	0.75 19	3.66 93	SW 4	0.51 13
125	0.75 19	NPT 1/4 G1/4	1.89 48	1.38 40	0.16 4	4.09 104	0.75 19	3.94 100	-	0.43 11
125	0.75 19	NPT 1/4 G1/4	1.89 48	1.38 40	0.16 4	4.09 104	0.75 19	3.94 100	-	0.43 11

Bore Ø	F ₄	F ₅	F ₆	F ₇	J	J ₁	H max	H ₁	LK Ø	SW
32	0.24 6	0.28 7	3.70 94	0.28 7	1/4•20 M 6	0.43 11	1.85 47	1.28 32.5	1.81 46	0.39 10
40	0.31 8	0.37 9.5	4.07 103.5	0.30 7.5	1/4•20 M 6	0.43 11	2.09 53	1.52 38.5	2.13 54	0.55 14
50	0.31 8	0.37 9.5	4.21 107	0.30 7.5	5/16•18 M 8	0.47 12	2.56 65	1.83 46.6	2.6 66	0.67 17
63	0.47 12	0.43 11	5.12 130	0.33 8.5	5/16•18 M 8	0.47 12	2.95 75	2.23 46.6	3.15 80	0.67 17
80	0.49 12.5	0.59 15	5.65 143.5	0.35 9	3/8•16 M 10	0.63 16	3.74 95	2.84 72.1	4.02 102	0.87 22
100	0.59 15	0.59 15	6.28 159.5	0.65 16.5	3/8•16 M 10	0.63 16	4.53 115	3.50 89	4.96 126	0.87 22
125	0.59 15	0.59 15	7.05 179	1.10 28	1/2•13 M 12	0.71 18	5.51 140	4.33 110	6.14 156	1.06 27
125	0.59 15	0.59 15	7.05 179	1.10 28	1/2•13 M 12	0.71 18	5.51 140	4.33 110	6.14 156	1.06 27

* Dimensions not according to ISO standards

** Dimensions B₄ & A₅ are ISO/CETOP

DZB Blocking Cylinder



Cylinder Mounts

Foot Bracket- Type A

Contact the Factory
for Further Information

The standard "A" type foot brackets are available. There is the possibility of interference with the Piston Rod. A Rod Extension Option eliminates the problem.

Rear Double- Clevis Type B

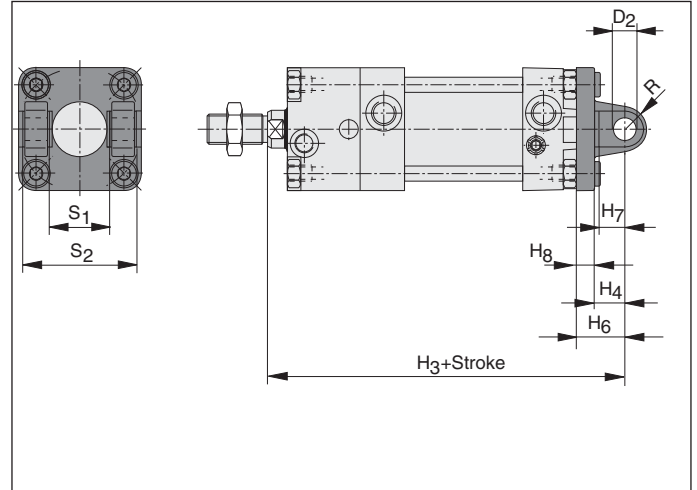

Rear Single Clevis- Type BA

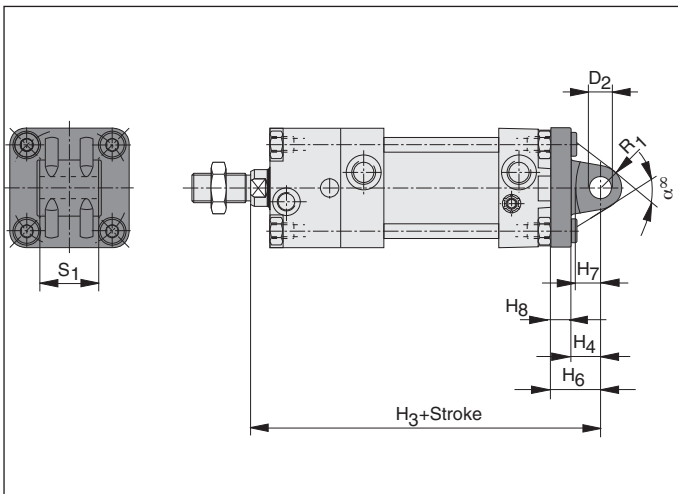

Rear Single Clevis with Spherical Bearing- Type BAS

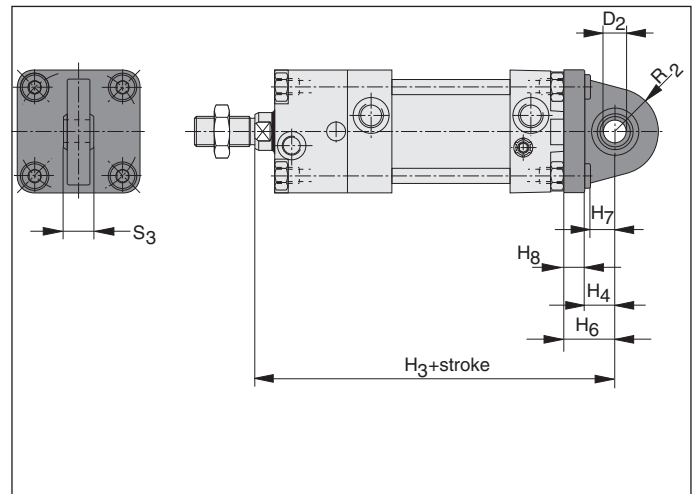

Rear Flange- Type D

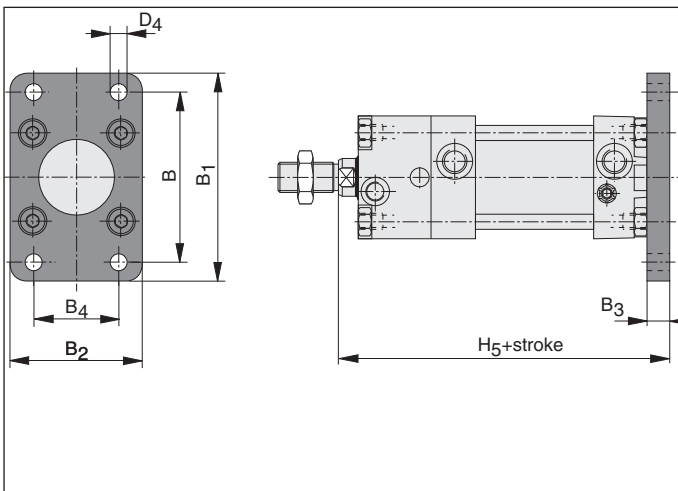

Trunnion*- Type EN * Bore32 to 100 Adjustable Bore 125 Fixed

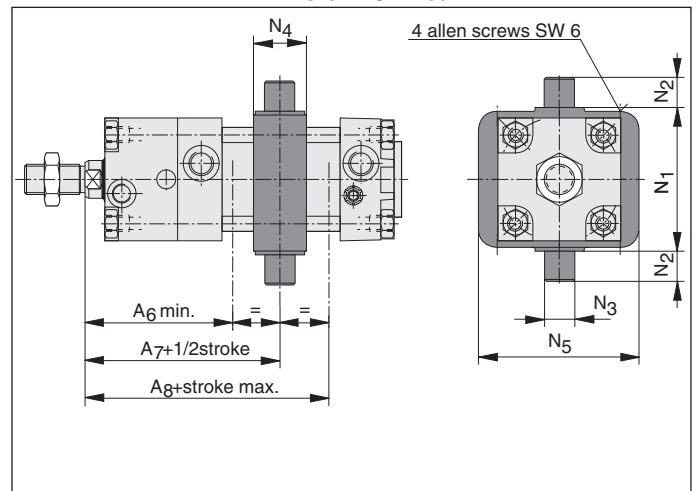

* Design: Allows mount to be adjusted between A7 and A8 for all units except the 125mm which requires the factory to set the position. When ordering, please supply the required mounting distance

DZB Blocking Cylinder



Cylinder Mounts

Bore Ø	A ₆ min	A ₇₊ 1/2 Stroke	A ₈ max Stroke	α°	B	B ₁	B ₂	B ₃	B ₄	D ₂ H7**
32	2.64 67	2.87 73	3.11 79	2.36 60	2.52 64	3.11 79	1.97 50	0.39 10	1.26 32	0.39 10*
40	2.83 72	3.27 83	3.66 93	2.36 60	2.83 72	3.54 90	2.20 56	0.39 10	1.42 36	0.47 12*
50	3.19 81	3.54 90	3.90 99	2.76 70	3.54 90	4.33 110	2.76 70	0.47 12	1.77 45	0.47 12*
63	4.51 114.5	4.53 115	4.55 115.5	2.36 60	3.94 100	4.72 120	3.03 77	0.47 12	1.97 50	0.63 16
80	4.80 122	4.96 126	5.12 130	2.76 70	4.96 126	6.02 153	3.94 100	0.63 16	2.48 63	0.63 16
100	5.24 133	5.39 137	5.55 141	2.76 70	5.91 150	7.01 178	4.72 120	0.63 16	2.95 75	0.79 20
125	5.51 140	5.98 152	6.46 164	2.36 60	7.09 180	8.66 220	5.51 140	0.79 20	3.54 90	0.98 25

Bore Ø	D ₄	H ₃₊ Stroke	H ₄	H ₅₊ Stroke	H ₆	H ₇	H ₈	N ₁	N ₂
32	0.28 7	5.59 142	0.47 12	5.12 130	0.87 22	0.43 11	0.39 10	1.97 50	0.47 12
40	0.35 9	6.30 160	0.59 15	5.71 145	0.98 25	0.55 14	0.39 10	2.48 63	0.63 16
50	0.35 9	6.69 170	0.63 16	6.10 155	1.06 27	0.59 15	0.43 11	2.95 75	0.63 16
63	0.35 9	7.95 202	0.83 21	7.17 182	1.26 32	0.79 20	0.43 11	3.54 90	0.79 20
80	0.47 12	8.82 224	0.83 21	8.03 204	1.42 36	0.79 20	0.59 15	4.33 110	0.79 20
100	0.55 14	9.61 244	0.98 25	8.62 219	1.61 41	0.94 24	0.63 16	5.20 132	0.98 25
125	0.63 16	10.83 275	1.18 30	9.65 245	1.97 50	1.14 29	0.79 20	6.30 160	0.98 25

Bore Ø	N ₃ e9	N ₄	N ₅	R	R ₁	R ₂	S ₁	S ₂	S ₃
32	0.47 12	0.87 22	2.56 65	0.35 9	0.41 10.5	0.71 18	1.02 26	1.77 45	0.55 14
40	0.63 16	1.10 28	2.95 75	0.43 11	0.51 13	0.83 21	1.10 28	2.05 52	0.63 16
50	0.63 16	1.10 28	3.35 85	0.47 12	0.51 13	0.91 23	1.26 32	2.36 60	0.63 16
63	0.79 20	1.38 35	3.94 100	0.59 15	0.67 17	1.06 27	1.57 40	2.76 70	0.83 21
80	0.79 20	1.38 35	4.72 120	0.63 16	0.67 17	1.14 29	1.97 50	3.54 90	0.83 21
100	0.98 25	1.57 40	5.31 135	0.79 20	0.83 21	1.34 34	1.97 50	4.33 110	0.98 25
125	0.98 25	1.57 40	6.50 165	0.98 25	0.98 25	1.57 40	2.76 70	5.12 130	1.22 31

DZB Blocking Cylinder



Technical Information

HOW A BLOCKING CYLINDER WORKS:

When pressure is supplied to the Control Port, the Floating Piston pivots on the ball positioning the Binding Plate perpendicular to the piston rod. This action releases the piston rod allowing the rod to move freely.

Caution:

1. The piston rod should not be allowed to rotate while in the locked position.
2. The Piston Rod should be stopped before operating the locking mechanism.

DZBA: Extend Lock Control Without Pressure to Control Port

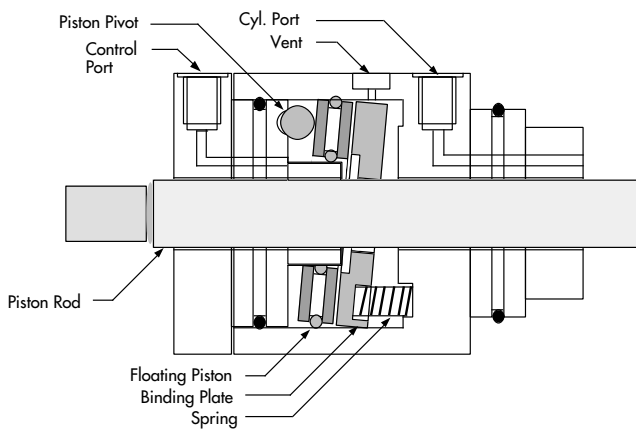

DZBA: Extend Lock Control Pressurized Control Port

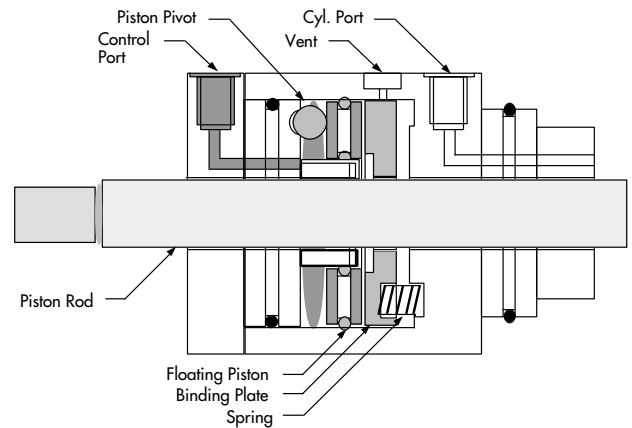

TYPICAL INSTALLATIONS

Example 1:

Compressed air from the main supply line is connected to both the valve and the control port of the cylinder. If the main supply pressure is lost, the control port releases the binding plate, locking the cylinder rod. The cylinder stays in this position until the main supply pressure returns to both the valve and the control port.

Example 2:

A 3-Way, Normally Open Valve independently supplies pressure to the control port. When the valve is energized the piston rod moves freely. De-energizing the valve locks the piston rod in position.

EXAMPLE: #1

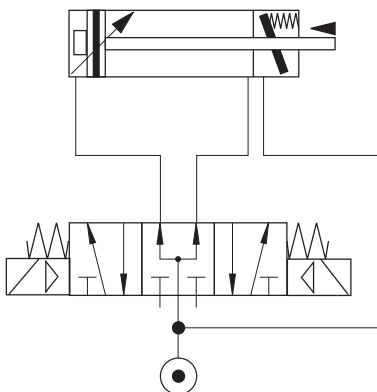

EXAMPLE: #2

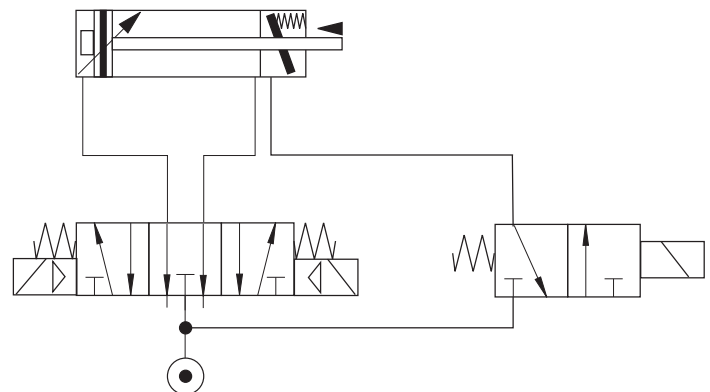

FSE Blocking Cylinder



Specifications

Characteristics	Symbol	Unit	Comments
General Characteristics			
Description			Blocking Unit (Locks in both directions)
Series			FSE - locks if pressure drops
Mounting			See dimensional drawing
Connection			Threaded
Ambient Temperature	J _{max}	°F(C)	176° (+80) Note: When using below freezing point (0°C) it is necessary to consult us
Medium Temperature	J _{max}	°F(C)	176° (+80)
Weight (mass)		lb(kg)	See table below
Installation Position			Optional
Medium			Filtered and regulated compressed air
Lubrication			Oil mist lubrication compatible with NBR seals
Material Cartridge Housing Clamping Jaw Cyl. piston rod			Aluminum Aluminum Bronze Stainless Steel
Pneumatic Characteristics			
Nominal Pressure	P _n	PSI(bar)	90 (6)
Cylinder Operating Pressure	P _{min} P _{max}	PSI(bar) PSI(bar)	15 (1) 145 (10)
Lock Release Pressure		PSI(bar)	≥60 - 145 (≥4 - 10)
Static Locking Force	lbf N	135 600	225 1000
		337 1500	495 2200
		674 3000	1124 5000
		1574 7000	
Cylinder Diameter		mm	32 40 50 63 80 100 125
Connection Size			G1/8 G1/4 G1/4 G3/8 G3/8 G1/2 G1/2
Piston Rod Diameter		mm	12 16 20 20 25 25 32
Piston Rod Extension		mm	43 46 56 56 78 78 111
Pilot Air Connection			M5 M5 G1/8 G1/8 G1/8 G1/8 G1/8

Weight		Cylinder Diameter (mm)							
Description		32	40	50	63	80	100	125	
Blocking Unit	lbs.	1.32	1.76	2.20	2.65	3.09	3.53	3.97	
	kg	0.60	0.80	1.00	1.20	1.40	1.60	1.80	
Basic cylinder with 100mm stroke and rod extension	lbs.	1.54	2.65	3.86	5.12	8.27	10.80	17.35	
	kg	0.70	1.20	1.75	2.32	3.75	4.90	7.87	

Series FSE

Ø32mm - 125mm

Versions:

- Blocking Unit with cylinder
- Blocking Unit without cylinder

AZ 50../...-FSE

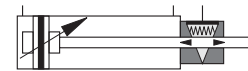

FSE..

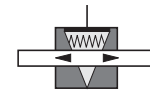

Blocking Unit holds the cylinder piston rod, if the signal pressure drops below 60 PSI (4 bar)

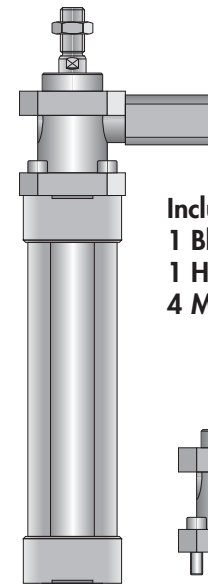

- Includes:**
- 1 Blocking Unit
 - 1 Housing
 - 4 Mounting Screws

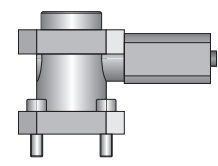

FSE Blocking Cylinder



Technical Information

Function

If the signal pressure (P) is removed, the piston rod (6) is locked by the two tilting plates (3 and 4).

The signal pressure (P) presses the piston (1) downward, pushing the two tilting plates (3 and 4) together. The piston rod (6) is then free to move. If the signal pressure (P) is removed from the piston chamber (5), the spring (2) pushes the two plates (3 and 4) apart. The wedge effect pushes the piston (1) upward, tilting the plates (3 and 4) apart and locking the piston rod (6).

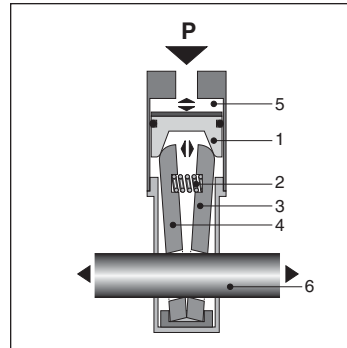

Important

- The Blocking Unit cannot be installed until the unit is unlocked, either by air pressure or by a suitable screw.
- When the cylinder piston rod is locked, it must not be rotated or subjected to external forces.

Circuit Diagrams for a Cylinder with an FSE Blocking Unit

Example 1: Horizontal Application with 5/3 Valve - RFB (dual center)

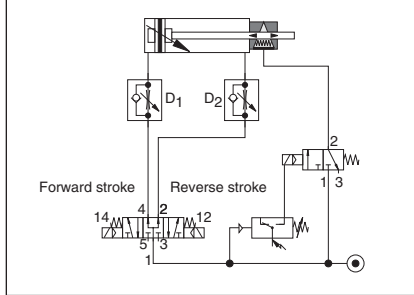

Example 2: Horizontal Application with 5/3 Valve - RFE (open center)

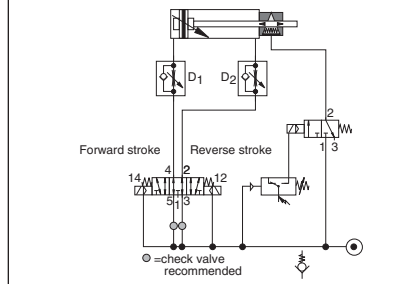

Example 3: Horizontal Application with Two 3/2 Valves

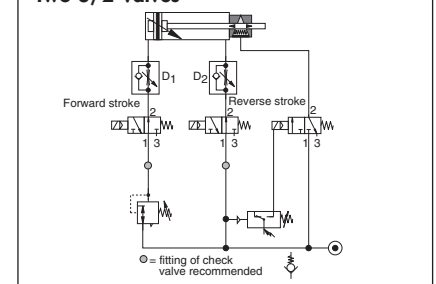

Examples 1 and 2:

When operating pressure is applied, the P/E converter is closed and the 3/2 valve is opened, i.e. the Blocking Unit is unlocked (working position).

The Blocking Unit is actuated with a 3/2 solenoid valve via a pressure switch. If the pressure drops, the pressure switch reacts and the Blocking Unit exhausts via the 3/2 way valve. The piston rod is locked. The use of the 5/3 valve ensures that both sides of the cylinder piston are pressurized. De-energizing the Blocking Unit allows the piston rod to remain in its present position.

Without the Blocking Unit, the piston rod would continue its forward stroke because of the different piston areas. After the pressure is equalized on both sides of the cylinder piston, the Blocking Unit can be actuated and the piston rod locked. The sequence of operations must therefore be correct. The flow control valves, D1 and D2, only control piston speed and have no influence on the actuation of the Blocking Unit. Installing a check valve increases safety because it prevents any movement of the piston before the Blocking Unit locks.

Example 4: Vertical Application with 5/3 Valve - RFE (open center)

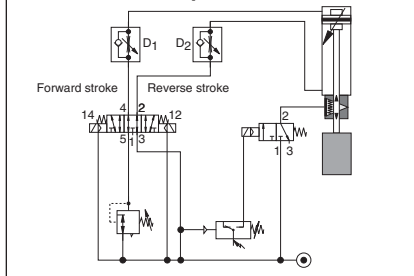

Example 5: Vertical Application with Two 3/2 N/O Valves

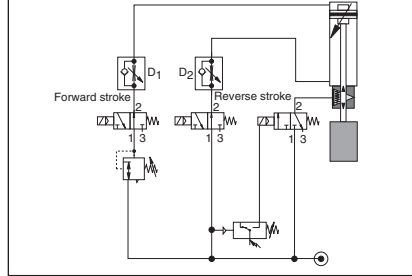

Example 2:

An additional regulator is installed in port #5, to compensate for the effect of the different areas on the two sides of the piston.

Example 3:

In contrast to Examples 1 and 2, a 5/3 valve is replaced by two 3/2 valves. It is similar to the control solution in Example 2. The choice will depend on the customer and the particular application.

FSE Blocking Cylinder



Dimensional Details

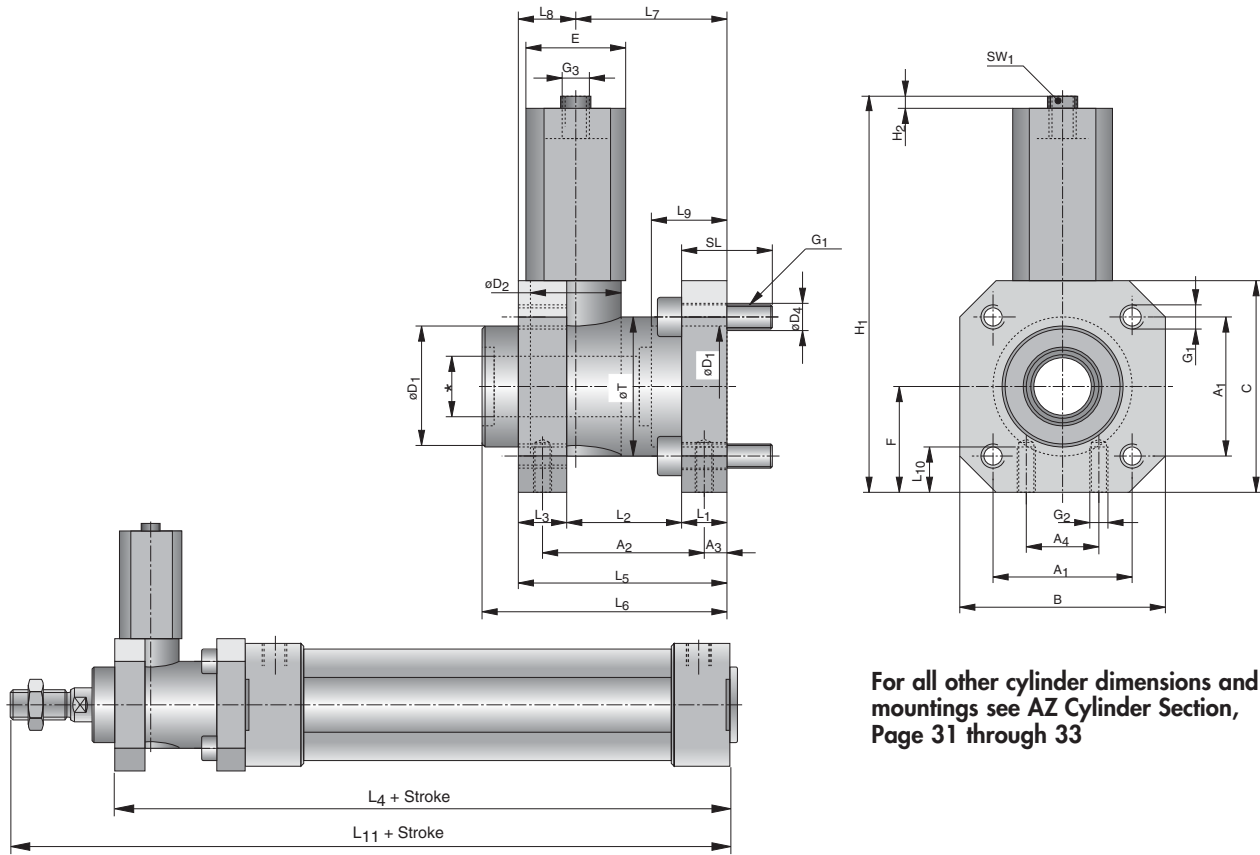

For all other cylinder dimensions and mountings see AZ Cylinder Section, Page 31 through 33

Bore ϕ	A ₁	A ₂	A ₃	A ₄	B	C	ϕD_1	ϕD_2	ϕD_4	E	F	G ₁	G ₂	G ₃	*	
32	1.28 32.5	1.57 40	0.17 4.2	0.63 16	1.89 48	1.97 50	1.18 30	0.79 20	0.26 6.6	0.89 22.7	0.98 25	M6	M5	M5	12	
40	1.50 38	1.81 46	0.18 4.5	0.83 21	2.20 56	2.28 58	1.38 35	0.94 24	0.26 6.6	1.09 27.7	1.14 29	M6	M5	M5	16	
50	1.83 46.5	2.13 54	0.45 11.5	0.94 24	2.68 68	2.76 70	1.57 40	1.18 30	0.33 8.5	1.29 32.7	1.38 35	M8	M6	G1/8	20	
63	2.22 56.5	2.17 55	0.30 7.5	1.26 32	3.23 82	3.35 85	1.77 45	1.50 38	0.33 8.5	1.61 41	1.67 42.5	M8	M8	G1/8	20	
80	2.83 72	2.76 70	0.39 10	1.73 44	3.94 100	4.13 105	1.77 45	1.57 40	0.43 11	1.96 49.7	2.07 52.5	M10	M8	G1/8	25	
100	3.50 89	2.76 70	0.39 10	2.36 60	4.72 120	5.12 130	2.17 55	1.89 48	0.43 11	2.15 54.7	2.56 65	M10	M8	G1/8	25	
125	4.33 110	3.74 95	0.43 11	2.95 75	5.51 140	5.91 150	2.36 60	2.56 65	0.51 13	2.56 64.9	2.95 75	M12	M10	G1/8	32	
Bore ϕ	H ₁	H ₂	L ₁	L ₂	L ₃	L ₄ +Stroke	L ₅	L ₆	L ₇	L ₈	L ₉	L ₁₀	L ₁₁ +Stroke	SL	SW ₁	ϕT
32	3.78 96	0.16 4	0.31 8	1.10 28	0.47 12	5.59 142	1.89 48	2.28 58	1.26 32.0	0.63 16.0	0.81 20.5	0.31 8	7.21 183	0.79 20	8	1.34 34
40	4.09 104	0.16 4	0.39 10	1.30 33	0.47 12	6.30 160	2.17 55	2.56 65	1.40 35.5	0.77 19.5	0.89 22.5	0.39 10	8.08 205	0.99 25	8	1.65 42
50	5.00 127	0.16 4	0.59 15	1.54 39	0.63 16	6.93 176	2.76 70	3.23 82	1.93 49.0	0.83 21.0	1.16 29.5	0.47 12	9.09 231	1.18 30	13	1.97 50
63	5.96 151.5	0.16 4	0.59 15	1.58 40	0.59 15	7.53 191	2.76 70	3.23 82	1.93 49.0	0.83 21.0	1.16 29.5	0.47 12	9.69 246	1.18 30	13	1.97 50
80	7.17 182	0.16 4	0.63 16	2.28 58	0.63 16	8.47 215	3.55 90	4.33 110	2.44 62.0	1.10 28.0	1.40 35.5	0.63 16	11.50 292	1.18 30	17	2.36 60
100	8.15 207	0.16 4	0.63 16	2.28 58	0.71 18	9.06 230	3.62 92	4.53 115	2.56 65.0	1.06 27.0	1.52 38.5	0.63 16	12.09 307	1.18 30	17	2.36 60
125	8.94 227	0.16 4	0.98 25	2.76 70	1.06 27	11.11 282	4.81 122	6.07 154	3.35 85.0	1.46 37	1.79 45.5	0.79 20	15.13 384	1.77 45	17	3.15 80

FSE Blocking Unit



Ordering Details

Ordering Details for AZ Cylinder with FSE Blocking Unit

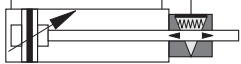
Description	Symbol	Bore Ø	Type #	Order #
Double acting, with adjustable cushions, magnetic piston, Blocking unit and rod extension		32mm	AZ5032/....-FSE	PA 58347-....
		40mm	AZ5040/....-FSE	PA 59267-....
		50mm	AZ5050/....-FSE	PA 60347-....
		63mm	AZ5063/....-FSE	PA 61287-....
		80mm	AZ5080/....-FSE	PA 62187-....
		100mm	AZ5100/....-FSE	PA 63087-....
		125mm	DZ 5125/....-FSE (M24x2)	PA 64017-....
		125mm	DZ 5125/....-FSE (M27x2)	PA 64027-....

Add stroke length (mm, 4 digits)

- Stroke lengths: any mm increment up to 500mm standard
- Contact factory for special stroke lengths

Ordering Details for FSE Blocking Unit (without cylinder)

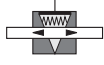
Description	Symbol	Bore Ø	Type #	Order #
Note: Requires cylinder with rod extension		32mm	FSE 032	KC 8227
		40mm	FSE 040	KC 8228
		50mm	FSE 050	KC 8229
		63mm	FSE 063	KC 8230
		80mm	FSE 080	KC 8231
		100mm	FSE 100	KC 8232
		125mm	FSE 125	KC 8233

Proximity Sensors/Brackets: See Page 73

FEU Linear Guide



Specifications

Features							
Installation	In any Position						
Temperature Range	Min. -4° F (-20° C) Max. +176° F (+80° C)						
Material							
Guide Body	Aluminium, Anodized						
Guide Rods	Stainless Steel						
Guide Bushing	Sintered Bronze						
Mounting Plate	Aluminium, Anodized						
Piston Rod Mounting	Stainless Steel						
Weight	Bore	ø8/10		ø12/16		ø20/25	
With 100mm Stroke	lbs. (kg)	0.44 (0.20)		0.84 (0.38)		1.50 (0.68)	
Per add. 100mm Stroke	lbs. (kg)	0.11 (0.05)		0.18 (0.08)		0.29 (0.13)	
Weight (mass)	Bore	ø32	ø40	ø50	ø63	ø80	ø100
With 100mm Stroke	lbs. kg	2.91 1.32	4.37 1.98	7.39 3.35	10.14 4.60	18.30 8.30	23.92 10.85
Per add. 100mm Stroke	lbs. kg	0.40 0.18	0.71 0.32	1.10 0.50	1.10 0.50	1.70 0.77	1.70 0.77

Series FEUG Linear Guide, "U-Form"

For cylinders conforming to
ISO 6431/6432
ø8mm - 100mm

Maximum working load in relation to overhang - FEUG version with plain bearings

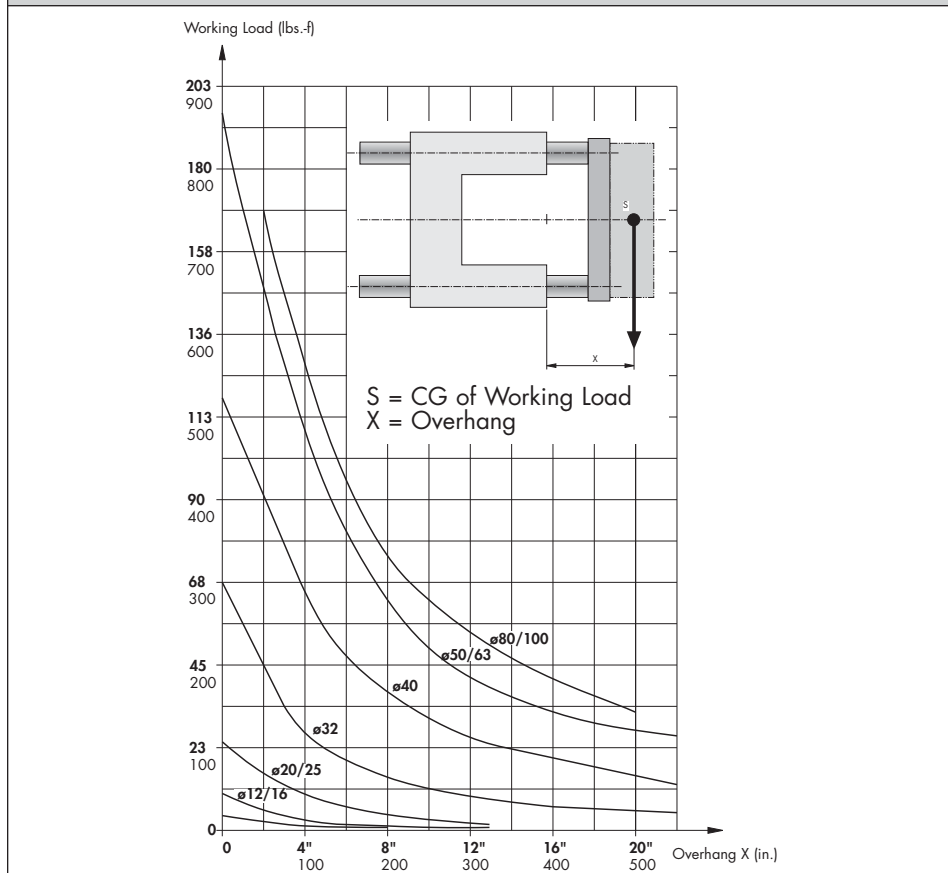

FEU Linear Guide



Ordering Information

Linear Guide, "U-Form"

Type: FEU

Example: Bore: Ø50mm
 Stroke: 160mm
 Type: FEUG 50/160
 Order No. PD 38019-0160

ISO 6432 Cylinders Plain Bearing: Type FEUG Bore Ø		8-10mm	12-16mm	20mm	25mm
Type #		FEUG 8-10/xx	FEUG 12-16/xx	FEUG 20/xx	FEUG 25/xx
Order #		PD 38013-	PD 38014-	PD 38015-	PD 38016-
Strokes (MM)					
(xx) 25		0025	—	—	—
50		0050	0050	0050	0050
100		0100	0100	0100	0100
160		—	—	0160	0160
200		—	0200	0200	0200
250		—	—	0250	0250
320		—	—	0400	0400

ISO 6431 Cylinders Plain Bearing: Type FEUG Bore Ø		32mm	40mm	50mm	63mm	80mm	100mm
Type #		FEUG 32/xx	FEUG 40/xx	FEUG 50/xx	FEUG 63/xx	FEUG 80/xx	FEUG 100/xx
Order #		PD 38017-	PD 38018-	PD 38019-	PD 38020-	PD 38021-	PD 38022-
Strokes (MM)							
50		0050	0050	0050	0050	0050	0050
100		0100	0100	0100	0100	0100	0100
160		0160	0160	0160	0160	0160	0160
200		0200	0200	0200	0200	0200	0200
250		0250	0250	0250	0250	0250	0250
320		0320	0320	0320	0320	0320	0320

Note: All units use metric mounting threads only.
 Contact factory for special stroke lengths.

Linear Guides Only: Corresponding Cylinders Need to be Ordered Separately!

Cylinder Details

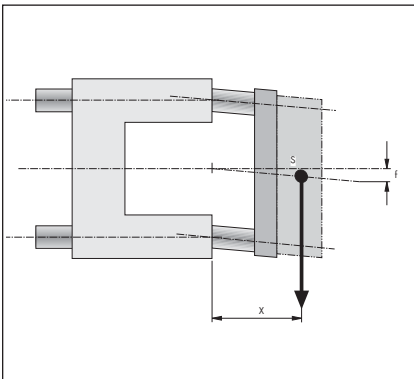

S = CG of working load
 X = Overhang
 f = Deflection

Deflection -FEUG version with plain bearings

Diagram 1 - Deflection with a working load of 23 lbs.

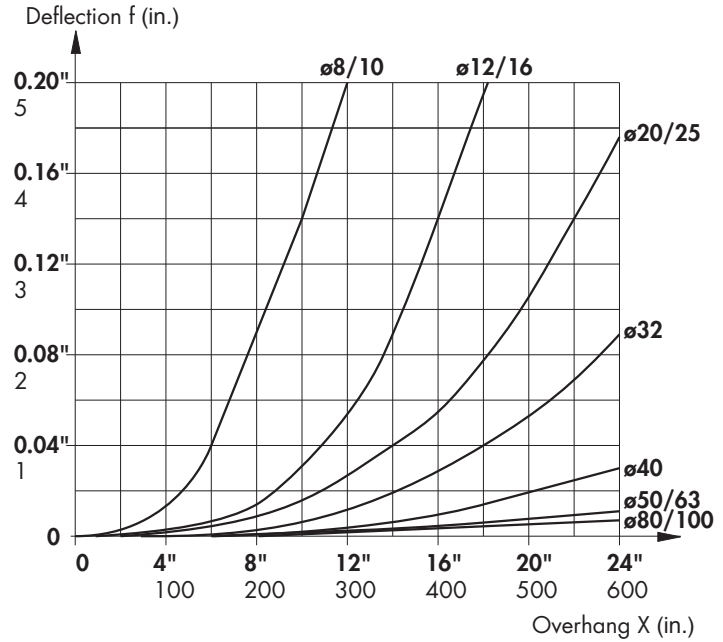

The total deflection is the sum of the deflection under own weight (Diagram 2) and the deflection under load (Diagram 1).
 The deflection for every 23 lb. load is shown in Diagram 1.

Diagram 2 - Deflection under own weight

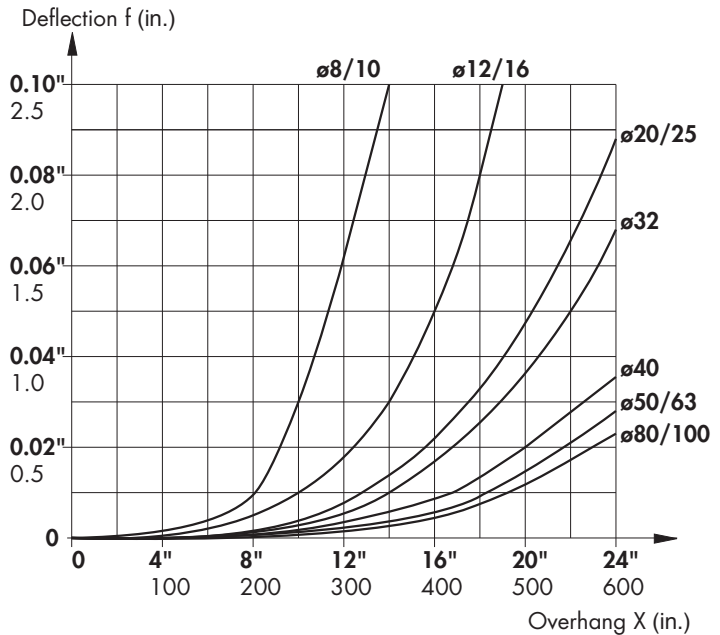

FEU Linear Guide



Dimensional Details

FEUG Ø8-25mm ISO 6432

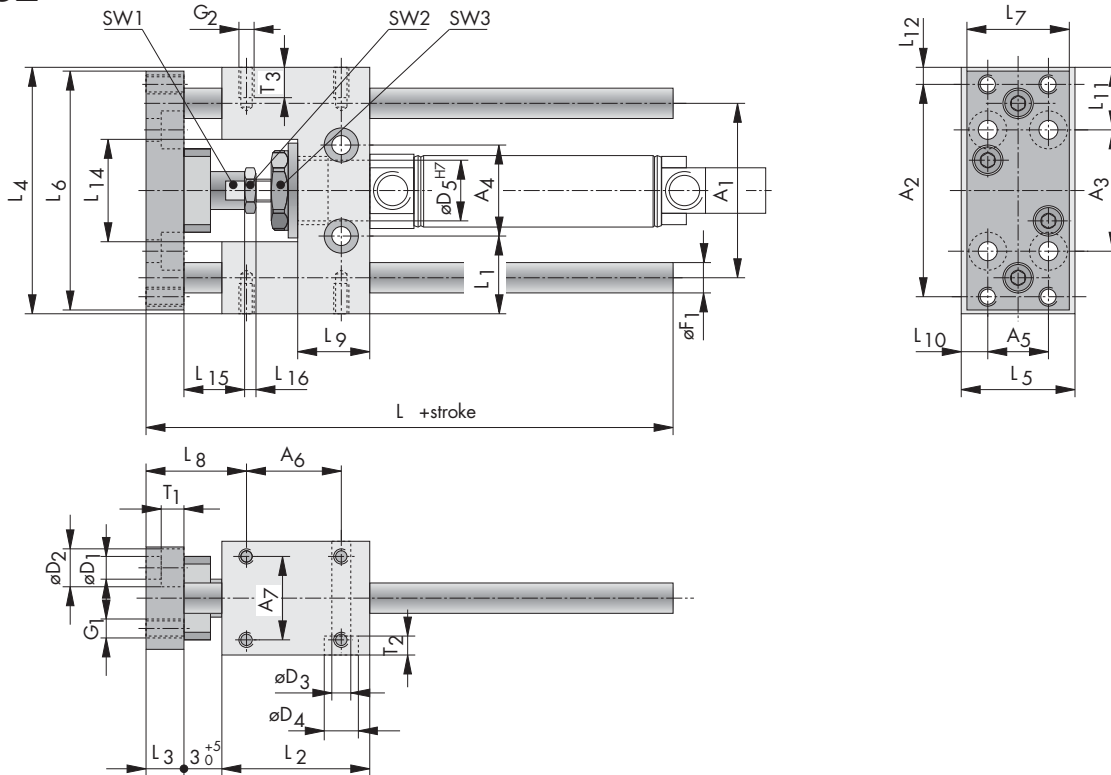

Bore Ø	A ₁	A ₂	A ₃	A ₄	A ₅	A ₆	A ₇	D ₁	D ₂	D ₃	D ₄	D ₅ ^{H7}	F ₁	G ₁	G ₂	L _{1+stroke}	L ₂	L ₃	L ₄
8	1.57	1.65	0.98	0.94	0.63	0.75	0.75	0.22	0.39	0.18	-	0.47	0.24			2.36	1.38	0.39	2.20
	40	42	25	24	16	19	19	5.5	10	4.5	-	12	6	M5	M4	60	35	10	56
10	1.57	1.65	0.98	0.94	0.63	0.75	0.75	0.22	0.39	0.18	-	0.47	0.24			2.36	1.38	0.39	2.20
	40	42	25	24	16	19	19	5.5	10	4.5	-	12	6	M5	M4	60	35	10	56
12	1.81	1.81	1.26	0.94	0.63	0.98	0.87	0.22	0.39	0.22	-	0.63	0.31			2.72	1.54	0.39	2.56
	46	46	32	24	16	25	22	5.5	10	5.5	-	16	8	M5	M4	69	39	10	65
16	1.81	1.81	1.26	0.94	0.63	0.98	0.87	0.22	0.39	0.22	-	0.63	0.31			2.72	1.54	0.39	2.56
	46	46	32	24	16	25	22	5.5	10	5.5	-	16	8	M5	M4	69	39	10	65
20	2.28	2.68	1.57	1.50	0.79	1.28	0.91	0.22	0.39	0.26	0.43	0.87	0.39			3.35	2.17	0.47	3.11
	58	68	40	38	20	32.5	23	5.5	10	6.6	11	22	10	M5	M6	85	55	12	79
25	2.28	2.68	1.57	1.50	0.79	1.28	0.91	0.22	0.39	0.26	0.43	0.87	0.39			3.35	2.17	0.47	3.11
	58	68	40	38	20	32.5	23	5.5	10	6.6	11	22	10	M5	M6	85	55	12	79
Bore Ø	L ₅	L ₆	L ₇	L ₈	L ₉	L ₁₀	L ₁₁	L ₁₂	L ₁₃	L ₁₄	L ₁₅	L ₁₆	SW1	SW2	SW3	T ₁	T ₂	T ₃	
8	1.02	2.13	0.98	0.83	0.67	0.20	0.61	0.28	0.63	0.94	0.75	0.09				0.22	-	0.31	
	26	54	25	21 ⁺⁵ ₀	17	5	15.5	7	16	24	19	2.2	9	a	15	5.7	-	8	
10	1.02	2.13	0.98	0.83	0.67	0.20	0.61	0.28	0.63	0.94	0.75	0.09				0.22	-	0.31	
	26	54	25	21 ⁺⁵ ₀	17	5	15.5	7	16	24	19	2.2	9	a	15	5.7	-	8	
12	1.18	2.48	1.06	0.77	0.75	0.28	0.65	0.16	0.81	1.06	0.63	0.13				0.22	-	0.31	
	30	63	27	19.5 ⁺⁵ ₀	19	7	16.5	4	20.5	27	16	3.2	9	a	19	5.7	-	8	
16	1.18	2.48	1.06	0.77	0.75	0.28	0.65	0.16	0.81	1.06	0.63	0.13				0.22	-	0.31	
	30	63	27	19.5 ⁺⁵ ₀	19	7	16.5	4	20.5	27	16	3.2	9	a	19	5.7	-	8	
20	1.34	2.99	1.26	0.94	0.98	0.28	0.77	0.22	0.81	1.46	1.14	0.16				0.22	-	0.55	
	34	76	32	24 ⁺⁵ ₀	25	7	19.5	5.5	20.5	37	29	4	13	a	27	5.7	-	14	
25	1.34	2.99	1.26	0.94	0.98	0.28	0.77	0.22	0.81	1.46	0.91	0.24				0.22	0.28	0.55	
	34	76	32	24 ⁺⁵ ₀	25	7	19.5	5.5	20.5	37	23	6	13	a	27	5.7	7	14	

FEHG & FEHK Linear Guide



Specifications

Features							
Installation	In any Position						
Temperature Range	Min. -4° F (-20° C) Max. +176° F (+80° C)						
Material							
Guide Body	Aluminium, Anodized						
Guide Rods	Stainless Steel for FEHG Version Stainless Steel, Hardened for FEHK Version						
Guide Bushing	Sintered Bronze for FEHG Version Linear Ball Bearings for FEHK Version						
Mounting Plate	Aluminium, Anodized						
Piston Rod Mounting	Stainless Steel						
Weight (mass)	Bore	ø32	ø40	ø50	ø63	ø80	ø100
With 4" (100mm) Stroke	lbs. (kg)	3.13 (1.42)	4.96 (2.25)	8.38 (3.80)	11.13 (5.05)	20.24 (9.18)	26.01 (11.80)
Per add. 4" (100mm) Stroke	lbs. (kg)	0.40 (0.18)	0.62 (0.28)	1.21 (0.55)	1.21 (0.55)	1.70 (0.77)	1.70 (0.77)

Series FEHG & FEHK Linear Guide, "H-Form"

For cylinders conforming to ISO 6431
 Ø32mm - 100mm

Maximum working load in relation to overhang - FEHG version with plain bearings

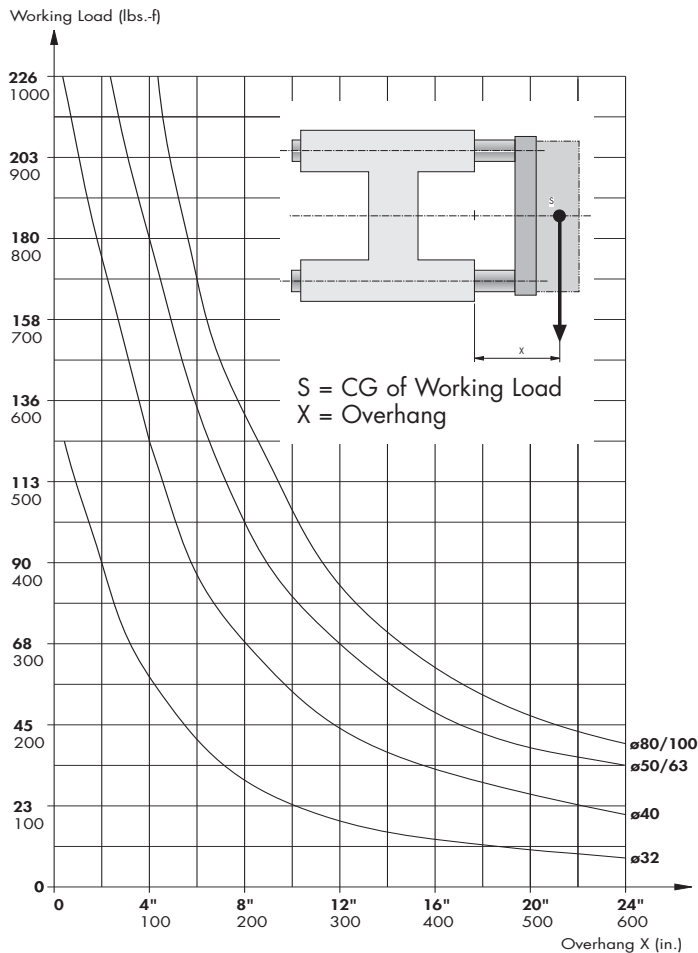

FEHG & FEHK Linear Guide



Ordering Information

Linear Guide, "H-Form"

Type: FEH

Example: Bore: Ø50mm
 Stroke: 160mm
 Type: FEHG 50/160
 Order No. PD 38003-0160

ISO 6431 Cylinders Plain Bearing: Type HG		32mm	40mm	50mm	63mm	80mm	100mm
Bore Ø		FEHG 32/xx	FEHG 40/xx	FEHG 50/xx	FEHG 63/xx	FEHG 80/xx	FEHG 100/xx
Type #							
Order #		PD 38001-	PD 38002-	PD 38003-	PD 38004-	PD 38005-	PD 38006-
Strokes	(MM)						
	50	0050	0050	0050	0050	0050	0050
	100	0100	0100	0100	0100	0100	0100
	160	0160	0160	0160	0160	0160	0160
	200	0200	0200	0200	0200	0200	0200
	250	0250	0250	0250	0250	0250	0250
	320	0320	0320	0320	0320	0320	0320

ISO 6431 Cylinders Roller Bearing: Type HK		32mm	40mm	50mm	63mm	80mm	100mm
Bore Ø		FEHK 32/xx	FEHK 40/xx	FEHK 50/xx	FEHK 63/xx	FEHK 80/xx	FEHK 100/xx
Type #							
Order #		PD 38007-	PD 38008-	PD 38009-	PD 38010-	PD 38011-	PD 38012-
Strokes	(MM)						
	50	0050	0050	0050	0050	0050	0050
	100	0100	0100	0100	0100	0100	0100
	160	0160	0160	0160	0160	0160	0160
	200	0200	0200	0200	0200	0200	0200
	250	0250	0250	0250	0250	0250	0250
	320	0320	0320	0320	0320	0320	0320

Note: All units use metric mounting threads only.
 Contact factory for special stroke lengths.

Linear Guides Only: Corresponding Cylinders Need to be Ordered Separately!

Cylinder Details

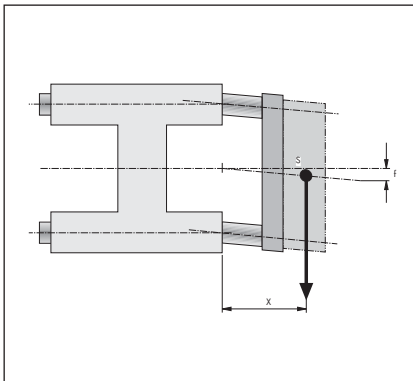

S = CG of working load
 X = Overhang
 f = Deflection

Deflection

-FEHG version with plain bearings and FEHK version with ball bearings

Diagram 1 - Deflection with a working load of 23 lbs.

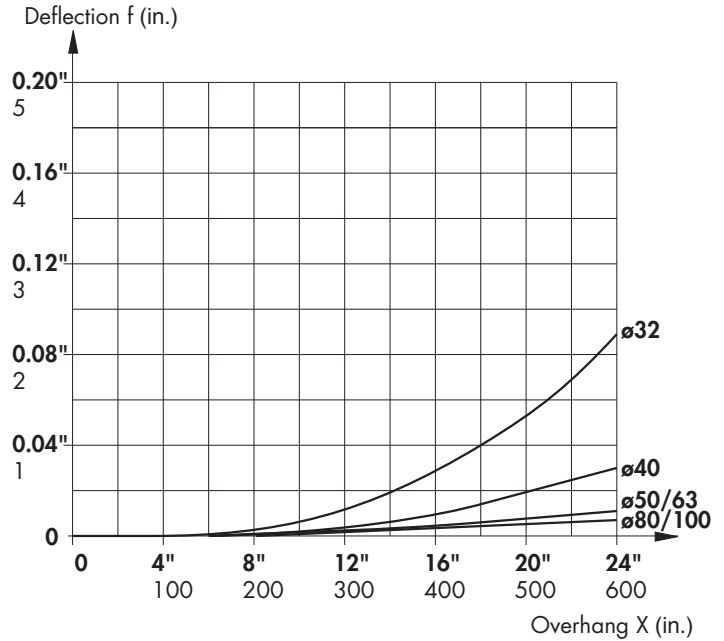

The total deflection is the sum of the deflection under own weight (Diagram 2) and the deflection under load (Diagram 1).
 The deflection for every 23 lb. load is shown in Diagram 1.

Diagram 2 - Deflection under own weight

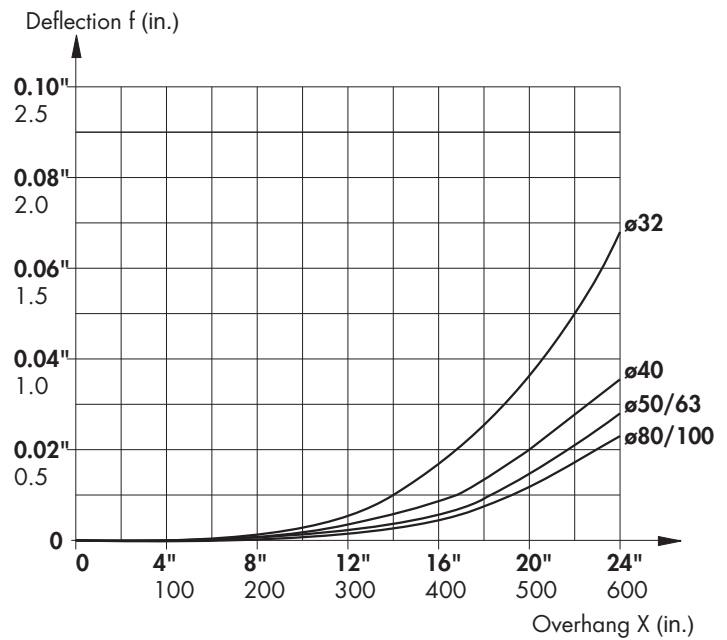

Cylinder Details

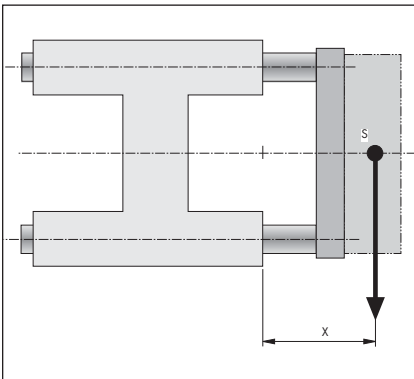

S = CG of working load
 X = Overhang

Maximum working load in relation to overhang -FEHK version with ball bearings

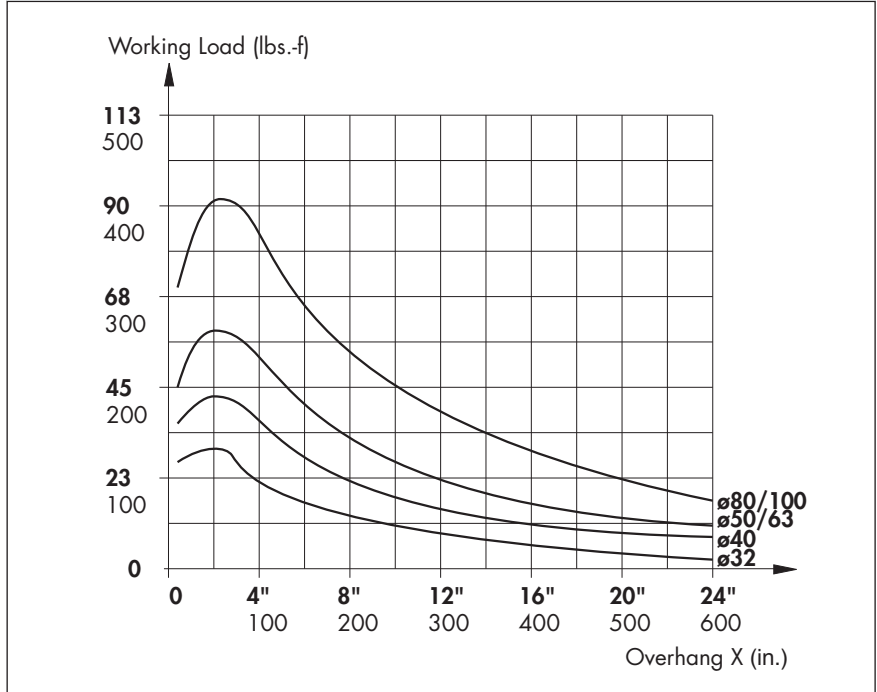

For short strokes, the working load figures obtained from the diagrams must be multiplied by a correction factor (k) (See Diagram).

In the working load curves for overhangs up to 60mm these short stroke corrections are already included.

In the case of impact loads, the maximum permissible working load must be halved.

Reduction of working load with short strokes -FEHK version with ball bearings

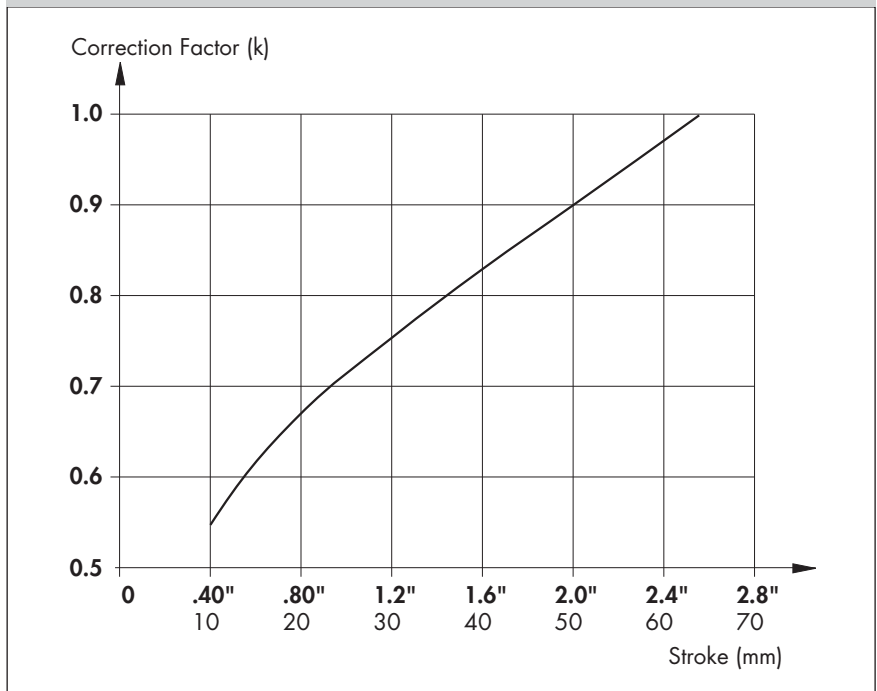

FEHG & FEHK Linear Guide



Dimensional Details

FEHG & FEHK Ø32-100mm ISO 6431

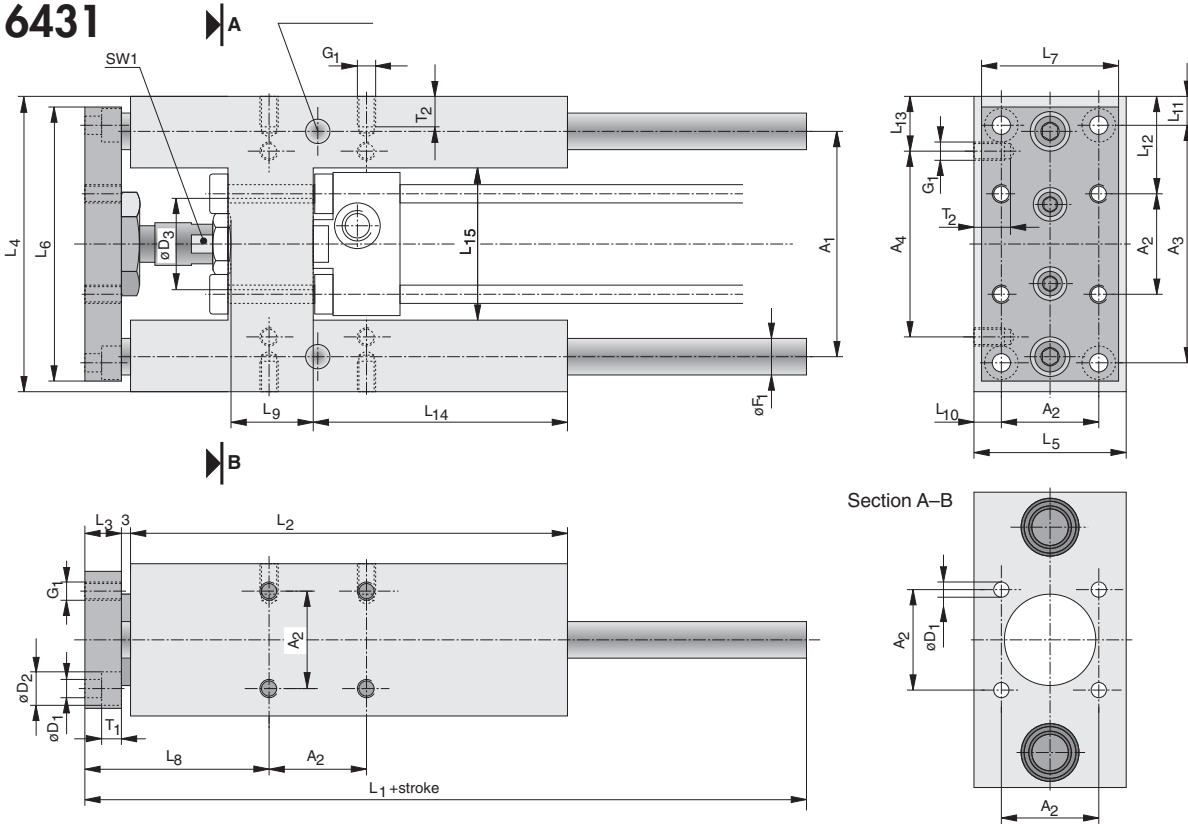

Bore Ø	A ₁	A ₂	A ₃	A ₄	D ₁	D ₂	D ₃	F ₁		G ₁	L _{1+stroke}	L ₂	L ₃	L ₄	L ₅
								HG	HK						
32	2.91 74	1.28 32.5	3.07 78	2.4 61	0.26 6.6	0.43 11	1.18 30	0.55 14	(0.47) (12)	M6	6.97 177	4.09 104	0.47 12	3.82 97	1.97 50
40	3.43 87	1.5 38	3.31 84	2.72 69	0.26 6.6	0.43 11	1.38 35	0.70 18	(0.63) (16)	M6	7.56 192	4.80 122	0.47 12	4.53 115	2.28 58
50	4.09 104	1.83 46.5	3.94 100	3.35 85	0.35 9	0.59 15	1.57 40	0.87 22	(0.79) (20)	M8	9.33 237	5.71 145	0.59 15	5.39 137	2.76 70
63	4.69 119	2.22 56.5	4.13 105	3.94 100	0.35 9	0.59 15	1.77 45	0.87 22	(0.79) (20)	M8	9.33 237	6.30 160	0.59 15	5.98 152	3.35 85
80	5.83 148	2.83 72	5.12 130	5.12 130	0.43 11	0.71 18	1.77 45	0.98 25		M10	11.02 280	8.46 215	0.79 20	7.44 189	4.13 105
100	6.77 172	3.5 89	5.91 150	5.91 150	0.43 11	0.71 18	2.17 55	0.98 25		M10	11.02 280	8.66 220	0.79 20	8.39 213	5.12 130
Bore Ø	L ₆	L ₇	L ₈	L ₉	L ₁₀	L ₁₁	L ₁₂	L ₁₃	L ₁₄	L ₁₅	SW1	SW2	T ₁	T ₂	
32	3.54 90	1.77 45	2.35 59.7	1.1 28	0.34 8.75	0.37 9.5	1.27 32.25	0.71 18	1.73 44	1.99 50.5			0.26 6.5	0.39 10	
40	4.33 110	2.13 54	2.48 63	1.3 33	0.39 10	0.61 15.5	1.52 38.5	0.91 23	2.01 51	2.30 58.5			0.26 6.5	0.39 10	
50	5.12 130	2.48 63	2.76 70.2	1.57 40	0.46 11.75	0.73 18.5	1.78 45.25	1.02 26	2.36 60	2.78 70.5			0.35 9	0.51 13	
63	5.71 145	3.15 80	2.89 73.5	1.57 40	0.56 14.25	0.93 23.5	1.88 47.75	1.02 26	2.95 75	3.37 85.5			0.35 9	0.51 13	
80	7.09 180	3.94 100	3.5 89	1.34 34	0.65 16.5	1.16 29.5	2.3 58.5	1.16 29.5	5.04 128	4.15 105.4		30	0.43 11	0.63 16	
100	7.87 200	4.72 120	3.56 90.5	1.54 39	0.81 20.5	1.24 31.5	2.44 62	1.24 31.5	5.04 128	5.13 130.4		30	0.43 11	0.63 16	



Sensors

Specifications

Sensors All Cylinders Ø8mm - 125mm

Reed Type

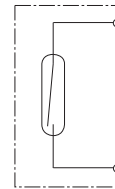

Hall Effect Type

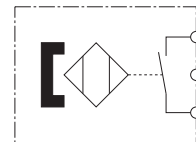

Features:

Cable or Plug-In Types

Reed Type

- LED
- Surge Supression
- DC-Reverse Polarity Protection

Hall Effect Type

- LED
- Surge Supression
- Reverse Polarity Protection

Features	
Type	REED HALL EFFECT NPN or PNP
Applicable Series Configurations	All Cylinders Individual Mounts for Different Cylinder Types
Construction Materials	
Body	Macrolon, Glass Fiber
Mounting Bracket	Aluminum, Anodized
Cable	PVC (Optional: PUR- Polyurethane)
Characteristics	
Operating Temperature	-13° F (-25°C) to 167° F (+75°C)
Accuracy	±0.0039"(0.1mm)
Voltage	Cable Type: 10 - 230 vAC/DC Reed 10 - 30 DC Hall
	Plug Type: 10 - 70 vAC/DC Reed 10 - 30 DC Hall
Switch Current	DZ, SZ 0.5A 0.2A
	R, ROV, RDV 1.5A 0.2A
Switch Capacity	DZ, SZ 20W, 30VA max.
	R, ROV, RDV 10W, 10VA max.
Switching Procedures	2200/min 200/sec
Electrical Protection	IP67 according to DIN 40050
Insulation	F according to VDE 0580
Connection	Cable (PVC) or Plug-in
Cycle Rate	(40 hZ)
Installation	In any Position
Weight	See Dimensions

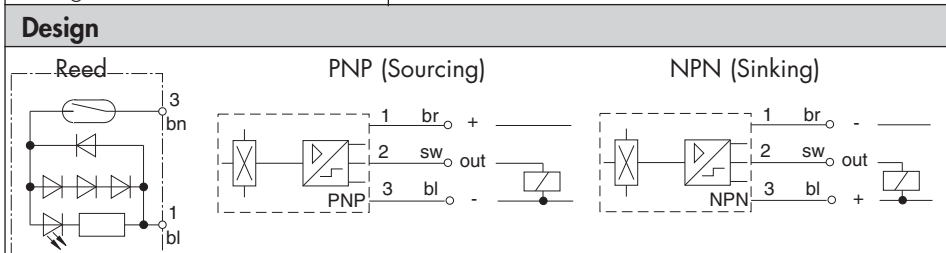

Switching Characteristics	"S" value					
	Bore	SZ		DZ/B/Q/V		ROV
	Reed	H.E	Reed	H.E	Reed	H.E
8-12	10	9	--	--	22	10
16	16	11	--	--	15	12
20	8	9	--	--	17	13
25	17	12	--	--	18	25
32	14	9	11	10	16	13
40	12	9	11	10	15	11
50	17	12	13	11	16	11
63	20	15	13	11	17	12
80	17	11	15	12	--	--
100	17	12	15	13	--	--
125	--	--	--	--	--	--

Sensors



Sensor Details

Description	Reed	Hall Effect PNP	Hall Effect NPN			
Series: AZ, AZV, SZ, NZK						
Cable Type: 8ft (2.5m)	KL 3043	KL 3055	KL 3059			
Plug-In Type:	KL 3046	KL 3054	KL 3060			
Series: R, ROV, RDV, RK						
Cable Type: 8ft (2.5m)	KL 3043	KL 3055	KL 3059			
Plug-In Type:	KL 3046	KL 3054	KL 3060			
Mounting Brackets						
Bore: 10	PD 45854	PD 45854	PD 45854			
Bore: 12	PD 45855	PD 45855	PD 45855			
Bore: 16	PD 45856	PD 45856	PD 45856			
Bore: 20	PD 45857	PD 45857	PD 45857			
Bore: 25	PD 45858	PD 45858	PD 45858			
Bore: 32	PD 45705	PD 45705	PD 45705			
Bore: 40	PD 45859	PD 45859	PD 45859			
Bore: 50	PD 45860	PD 45860	PD 45860			
Bore: 63	PD 45861	PD 45861	PD 45861			
Cable Set for Plug-In Sensors						
	Push Type	Twist Type	Push Type	Twist Type	Push Type	Twist Type
Length: 8 ft (2.5m)	KY 3240	KC 3102	KY 3240	KC 3102	KY 3240	KC 3102
Length: 16 ft (5m)	KY 3241	KC 3104	KY 3241	KC 3104	KY 3241	KC3104
Series: AZZ, DZB, DZBA, DZ						
8ft (2.5m)	KY 3235	KL 3237	KL 3238	KC 3048	KC 3049	
	KY 3236					
Mounting Brackets						
Bore: 32, 40, 50, 63	KY 3217	KY 3217	KY 3217	KY 3217	KY 3217	
Bore: 80, 100, 125	KY 3218	KY 3218	KY 3218	KY 3218	KY 3218	
Bore: 160, 200	KY 3219	KY 3219	KY 3219	KY 3219	KY 3219	
Bore: 250	KC 3146	KC 3146	KC 3146	KC 3146	KC 3146	

Reed Sensor Wiring Examples:

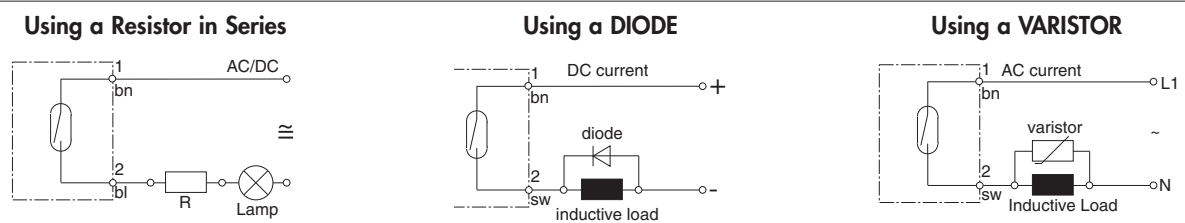

For all cylinders except DZB & DZ cylinders

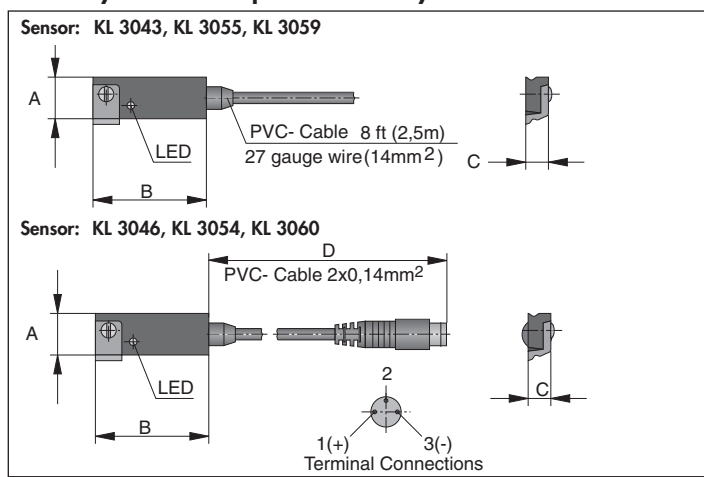

Wiring Connections for all sensors

	1 (+)	2	3 (-)
Reed	Brown (br)		White
PNP	Brown (br)	Black (sw)	Blue (bl)
NPN	Brown (br)	Black (sw)	Blue (bl)

Dimensions	INCH/mm			
	A	B	C	D
Sensors- All	0.43/11	1.18/30	0.24/6	3.94/100

Weights	ozs./kg	Sensor w/bracket
Cable Type		1.59/0.045
Plug-in Type		0.35/ 0.010

Sensors



Air Piloted Switch

Features	
Type	3/2 Valve- NC, 2 Position/Spring Return 3 way
Applicable Series	AZ, AZV
Construction Materials	
Body	Macrolon, Glass Fiber
Mounting Bracket	Aluminum, Anodized
Connection	3- 3mm O.D. Barbs
Characteristics	
Operating Temperature	14° F (-10°C) to 140°F (+60°C)
Operating Pressure	30 PSI (2 bar) to 90 PSI (6 bar)
Normal Operating Pressure	90 PSI (6 bar)
Flow	Cv 0.04 (40 l/min)
Cycle Rate	40 Hz
Switching Accuracy	± 0.008" (0.2 mm) w/o Air
Filtration	40 Micron
Media	Filtered and Regulated Compressed Air
Installation	In any Position
Weight	Sensor 0.49 ozs (0.014 kg) Sensor & Bracket 0.99 ozs (0.028 kg)
Part Number	
Sensor – Air Type	KZ 2364
Mounting Bracket	KC 8255

Sensors

Ø32mm - 100mm

3-Way Normally Closed Valve

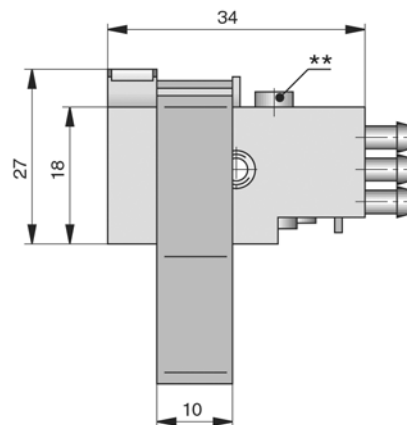
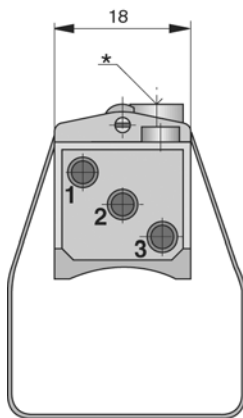
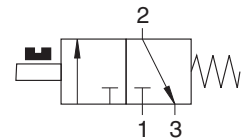



Sensors

Welding Proof Switch

Features	
Type	Hall Effect; NPN or PNP
Applicable Series	AZ, SZ
Construction Materials	
Body	PA12-GF30 Metal Housing
Mounting Bracket	Aluminum, Anodized
Connection	3-Pole Connector M12x1
Characteristics	
Operating Temperature	-13° F (-25°C) to 158°F (70°C)
Service Life	10x10 ⁶ Switching Cycles
Hysteresis	≤1.0mm
Repeatability	≤0.1mm
Voltage	10-30 vDC
Current Drop	1.8 vDC Max.
Current Consumption	2.0 mA Max.
Switching Current	.2A Max.
Switching Frequency	40 Hz
Electrical Protection	IP 67
Operation Indicator	LED
Part Number	
Sensor – PNP Type	KC 3372
Sensor – NPN Type	KC 3375
Mounting Bracket	KC 8293

Sensors

Ø32 - 100mm

Version

- PNP or NPN
- LED Light
- Short Circuit Protection
- Pole Reversal Protection

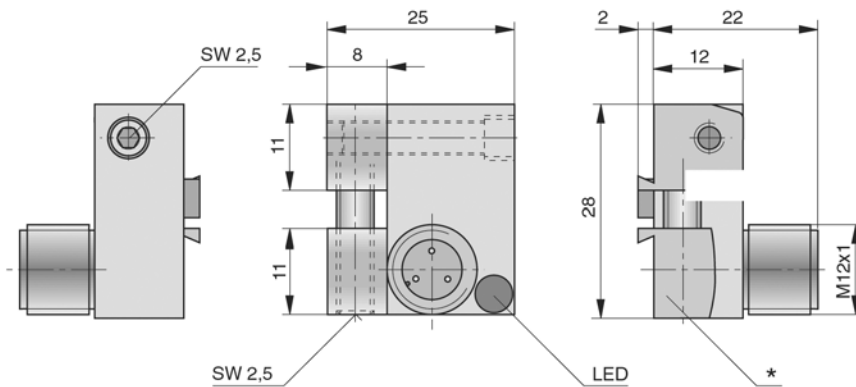

Spare Parts



AZV Replacement Parts

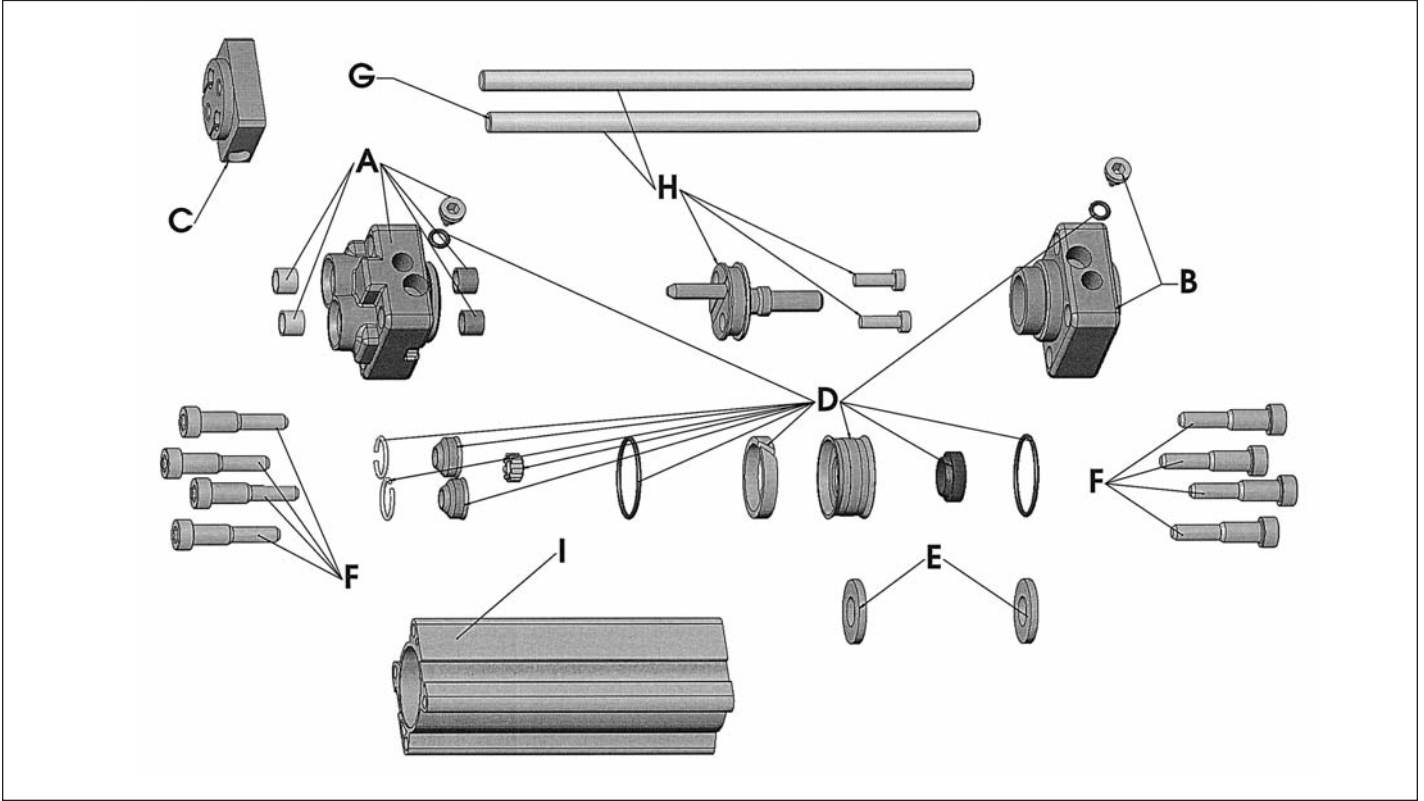

Spare Parts



AZV Twin Rod Cylinder

		Bore Ø						
		25mm	32mm	40mm	50mm	63mm	80mm	100mm
A. Front Head Twin Rod- AZV	INCH Metric		PD 28543 PD 27147	PD 28544 PD 27148	PD 28545 PD 27149	PD 28546 PD 27150	PD 28547 PD 27151	PD 28548 PD 27152
Front Head Sgl Rod- AZV 3D	INCH Metric		PD 26432 PD 21230	PD 26433 PD 21231	PD 26434 PD 21232	PD 26435 PD 21233	PD 26436 PD 23041	PD 26437 PD 21235
B. Rear Head Twin Rod- AZV	INCH Metric		PD 24505 PD 21236	PD 24511 PD 21237	PD 24517 PD 21238	PD 24523 PD 21239	PD 24529 PD 23047	PD 24535 PD 21241
C. Tooling Plate Assembly	INCH Metric		PD 24506 PD 23981	PD 24512 PD 23982	PD 24518 PD 23983	PD 24524 PD 23984	PD 24530 PD 23985	PD 24536 PD 23986
D. Seal Kits* AZV Std cylinder	NBR VITON	PD 29168	PD 23003 PD 25555	PD 23004 PD 25556	PD 23005 PD 25557	PD 23006 PD 25558	PD 23007 PD 25031	PD 23008 PD 25030
Seal Kits AZV 3D	NBR VITON		PD 24464	PD 24465 Contact factory	PD 24147 for details	PD 24466	PD 24467	PD 24468
Seal Kits AZV 4D	NBR VITON		PD 24475	PD 24476 Contact factory	PD 24477 for details	PD 24478	PD 24479	PD 24480
E. Magnet Ring			PD22466	PD 22465	PD22188	PD22298	PD22543	PD22544
F. End Cap Screws	INCH MM		2014-0352 2014-0301	2014-0352 2014-0301	2014-0552 2014-0501	2014-0552 2014-0501	2014-0852 2014-0802	2014-0852 2014-0802
G. Piston Rod Each rod	(+ stroke) INCH MM		4410-0351+ 4410-0301+	4410-0451+ 4410-0401+	4410-0551+ 4410-0501+	4410-0651+ 4410-0601+	4410-0851+ 4410-0801+	4410-1051+ 4410-1001+
H. Piston/Rod Assy (Piston, magnet, Rods and complete seal kit)	(+ stroke) INCH MM		4354-0351+ 4354-0301+	4354-0451+ 4354-0401+	4354-0551+ 4354-0501+	4354-0651+ 4354-0601+	4354-0851+ 4354-0801+	4354-1051+ 4354-1001+
I. AZV-U Barrel- With 8 assy screws	(+ stroke) INCH MM		4330-0351+ 4330-0301+	4330-0451+ 4330-0401+	4330-0551+ 4330-0501+	4330-0651+ 4330-0601+	4330-0851+ 4330-0801+	4330-1051+ 4330-1001+

* NOTE: Seal Kits include all rubber seals in the cylinder. Piston, cushion, barrel, & rod seals

Seal Kits

ISO CYLINDER - AZ

Seal Kits: AZ

Bore Ø	Order # NBR	Order # Viton
32mm	PD 39169	PD 39499
40mm	PD 39170	PD 39500
50mm	PD 39171	PD 39501
63mm	PD 39172	PD 39502
80mm	PD 39173	PD 39503
100mm	PD 39174	PD 39504

AZD

Order # NBR
PD 39381
PD 39382
PD 39383
PD 39384
PD 39385
PD 39386

ISO CYLINDER - DZ

Seal Kits: DZ

Bore Ø	Order # NBR	Order # Viton
125mm	PD 23011	PD 26969
160mm	PD 23013	PD 26995
200mm	PD 25006	PD 27427
250mm	PD 25872	PD 27976

COMPACT CYLINDER - SZ

Seal Kits: SZ, SZV

Bore Ø	Order # NBR
12mm	PD 35419
16mm	PD 35420
20mm	PD 35421
25mm	PD 35422
32mm	PD 44381
40mm	PD 44382
50mm	PD 44383
63mm	PD 44384
80mm	PD 44385
100mm	PD 44386

SZD

Order # NBR
—
—
—
—
PD 44489
PD 44490
PD 44491
PD 44492
PD 44493
PD 44494

COMPACT CYLINDER - NZK

Seal Kits: NZK

Bore Ø	Order # NBR	Order # Viton
32mm	PD 41478	PD 41574
40mm	PD 41479	PD 41575
50mm	PD 41480	PD 41576
63mm	PD 41481	PD 41577
80mm	PD 41482	PD 41578
100mm	PD 41483	PD 41579

NZKD

Order # NBR
PD 42095
PD 42096
PD 42097
PD 42098
PD 42099
PD 42100

BLOCKING CYLINDER - DZB

Seal Kits: DZB

Bore Ø	Order # NBR	Order # Viton
32mm	PD 30091	PD 30147
40mm	PD 30093	PD 30149
50mm	PD 30095	PD 30151
63mm	PD 27727	PD 28770
80mm	PD 26059	PD 28771
100mm	PD 26060	PD 28772
125mm	PD 26061	PD 28773

Seal Kits: DZBA

Bore Ø	Order # NBR	Order # Viton
32mm	PD 30092	PD 30147
40mm	PD 30094	PD 30149
50mm	PD 30096	PD 30151
63mm	PD 27727	PD 28770
80mm	PD 26059	PD 28771
100mm	PD 26060	PD 28772
125mm	PD 30743	PD 28745

All SEAL KITS INCLUDE:

Piston Seal, Rod Seal(s), Rod Seal Retaining Ring(s), Cushion Seals, Cushion Needle Seals, End Cap Seals.