



**CYLINDERS**

*The responsive solution*

VA Series

# Valve Actuator

A detailed 3D rendering of a valve actuator, showing its rectangular body, a central rod, and a valve stem at the bottom. The actuator is shown in a perspective view, highlighting its mechanical components.

2201 Highway 31 S  
Hartselle, AL 35640

tel 256.751.2548  
fax: 256.751.2189

[www.jitcylinders.com](http://www.jitcylinders.com)

2" to 24"  
Up to 150 PSI  
100% Factory Tested  
Steel Construction

## Air Valve Actuator Cylinders

Features			
»	Bore Sizes - 2.5" thru 24"	»	Multiple Rod End Styles
»	Pressure Rated for 150 psi Air	»	Standard Temperature -100°F to +165°F
»	100% Factory Tested	»	Forces to 68,000 lbs.
»	Ships in One day	»	24 Hour Customer Support

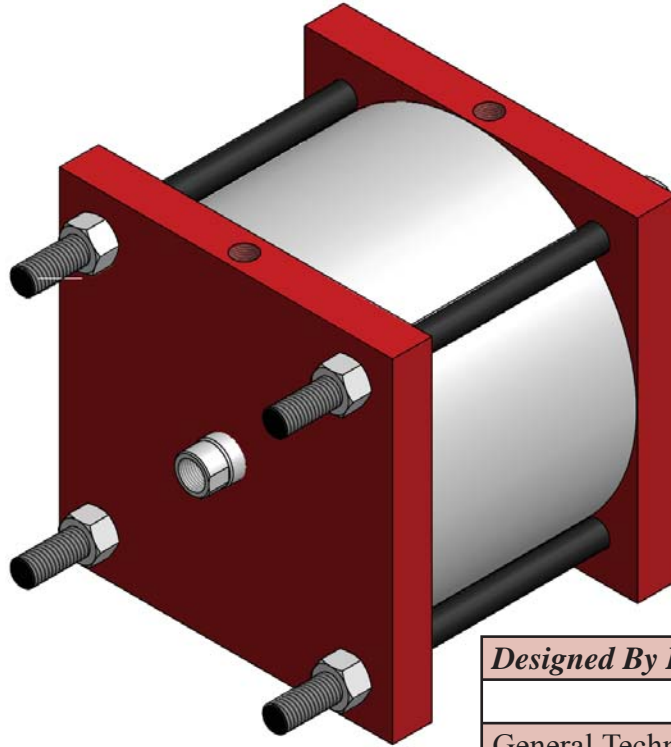

### Designed By Industry - For Industry

#### General Technical Data

The VA Series combines a cost-effective design with proven dependability. It is a repairable OEM, interchangeable cylinder line that is specifically designed to give our customers an economical alternative to NFPA industrial cylinders. This non-lube valve actuator series offers viable solutions to tight budgets without sacrificing quality.

#### Heavy Duty Rod Bearing

Unitized rod bearing ensures maximum support and wear resistance. The bearing is piloted into a precision head to ensure concentricity.

#### Superior Sealing Systems

Sealing system has been designed to provide optimum performance across broad velocities, pressure and temperature ranges with a variety of fluids.

#### Cylinder Barrel

Heavy wall DOM steel tubing is honed and chromed to a micro finish bore. DOM tube processing insures straighter and more concentric barrels while providing greater impact resistance for durability and long life.

Features	Design	Benefit
Steel Barrel	All Bore Sizes up to 8" Honed to 10-15 RMS Barrel ID Chrome Plated	Exceptional Durability and Effectiveness. Low Break-away force for smooth consistent cylinder cycling. Corrosion and dent resistant.
Steel Piston Rod	Piston rods are high yield strength, ground polished and chrome plated.	Strength for long life. Flexibility to prevent premature rod breakage.
One Piece Designed Piston	Machined from ductile iron for higher tensile strength, yield, and elongation than standard gray iron.	Wide bearing surface design reduces bearing loads while ensuring stability, concentricity, and parallelism to the barrel.
Tie Rods	100K minimum yield material with rolled threads.	Rolled threads provide increased strength compared to cut threads.

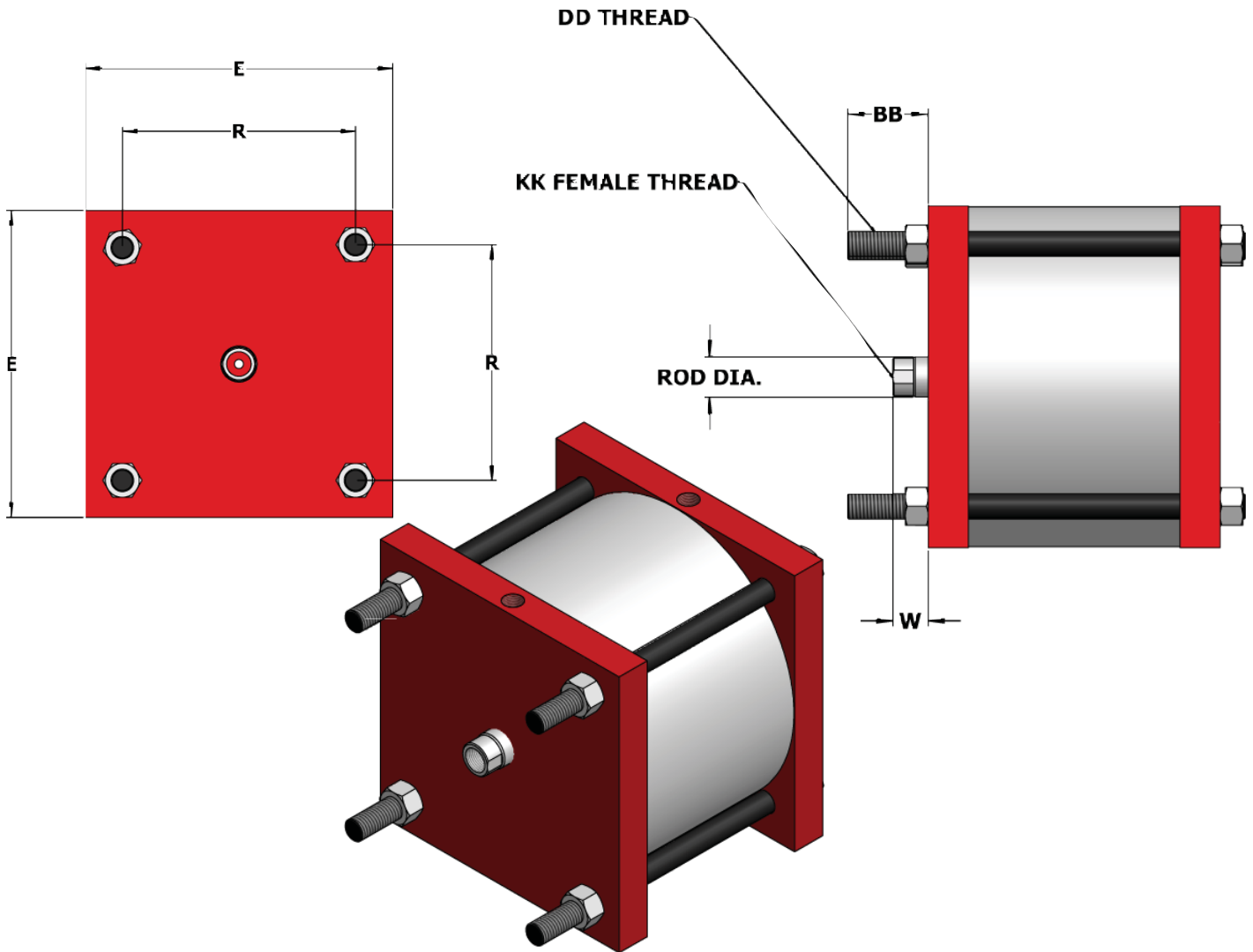

## VA Series Valve Actuator Mounting Dimensions

Standard Dimensions												
Bore	Rod	KK	E	G	J	NPT	W	BB	DD	K	R	LB +Stroke
2.5	0.63	7/16-20	3.0	1.0	1.0	0.25	0.63	1.13	5/16-24	0.31	2.19	3.0
3.25	1.0	3/4-16	4.0	1.0	1.0	0.25	0.75	1.38	3/8-24	0.38	2.76	3.0
4.0	1.0	3/4-16	4.5	1.0	1.0	0.38	0.75	1.38	3/8-24	0.38	3.32	3.0
5.0	1.0	3/4-16	5.5	1.0	1.0	0.38	0.75	1.81	1/2-20	0.44	4.10	3.0
6.0	1.0	3/4-16	6.5	1.0	1.0	0.38	0.88	1.81	1/2-20	0.44	4.88	3.25
7.0	1.0	3/4-16	8.0	1.0	1.0	0.38	0.88	2.0	5/8-18	0.56	5.73	3.5
8.0	1.0	3/4-16	9.0	1.0	1.0	0.38	0.88	2.0	5/8-18	0.56	6.44	3.5
10.0	1.0	3/4-16	11.00	1.25	1.25	0.5	1.0	2.25	3/4-16	0.69	7.92	4.13
12.0	1.38	1-14	12.75	1.25	1.25	0.5	1.0	2.25	3/4-16	0.69	9.40	4.13
14.0	1.38	1-14	14.75	1.5	1.5	0.75	1.0	2.50	7/8-14	0.81	10.90	4.75
16.0	1.75	1-14	17.0	1.5	1.5	0.75	1.25	2.75	1-14	0.88	12.59	5.0
18.0	2.0	1 1/2-12	19.0	1.75	1.75	0.75	1.5	3.25	1 1/8-12	1.0	14.14	5.75
20.0	2.0	1 1/2-12	21.0	2.0	2.0	0.75	1.5	3.25	1 1/4-12	1.25	15.77	6.5
22.0	2.5	1 7/8-12	23.0	2.0	2.0	0.75	1.63	3.25	1 1/4-12	1.25	17.18	7.5
24.0	3.5	2 1/2-12	25.25	2.5	2.5	0.75	2.25	3.5	1 1/4-12	1.25	18.74	8.5

# VALVE ACTUATOR CYLINDER MODEL CODE

**VA**      **MX3**      **8"**      **12"**      **1"**      **N**      **B**      **S**  
**1**      **2**      **3**      **4**      **5**      **6**      **7**      **8**

## 1 Model Series

VA Air Cylinder for Valve Operator Applications

## 2 Mounting Style

MX3 Extended Head End

## 3 Bore Size (2.5" - 22")

See Pressure tables

## 4 Stroke Length (.001" - 60")

Available in increments of .001"

## 5 Ram Diameter (.625" - 3.5")

Chrome Plated to 10 RMS finish

## 6 Port Styles

S SAE  
 N NPT  
 B BSPP

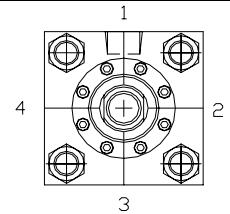

## 7 Seals

P Polyurethane  
 B Nitrile  
 V Viton

## 8 Specials

Adjustable Strokes and Cushions  
 Double Rod End  
 Electroless Nickel Plated  
 Proximity Switches  
 Special, Rotated, or Oversize Ports  
 Spring Return (open or close)  
 Stainless Steel Piston Rod and Barrel  
 Water Service, AWWA

## Features and Benefits

Features	Design	Benefit
Steel Barrel or Pollygon Barrel	All Bore Sizes Honed to 10-15 RMS Barrel ID Chrome Plated	Exceptional Durability and Effectiveness. Low Break-away force for smooth consistent cylinder cycling. Corrosion and dent resistant.
Steel Piston Rod	Piston rods are high yield strength, ground polished and chrome plated.	Strength for long life. Flexibility to prevent premature rod breakage.
One Piece Designed Piston	Machined from ductile iron for higher tensile strength, yield, and elongation than standard gray iron.	Wide bearing surface design reduces bearing loads while ensuring stability, concentricity, and parallelism to the barrel.
Tie Rods	100K minimum yield material with rolled threads.	Rolled threads provide increased strength compared to cut threads.

# Theoretical Forces Developed By Cylinders

## Cylinder Pressure Chart

Bore	Rod Dia	Push Area	Pull Area	Forces in Pounds at Various Pressures (PSI)											
				25 PSI		50 PSI		75 PSI		100 PSI		125 PSI		150 PSI	
				Push	Pull	Push	Pull	Push	Pull	Push	Pull	Push	Pull	Push	Pull
2.50	0.63	4.91	4.60	123	115	246	230	368	345	491	460	614	575	737	690
3.25	1.00	8.30	7.52	208	188	415	376	623	564	830	752	1,038	939	1,245	1,127
4.00	1.00	12.57	11.79	314	295	629	589	943	884	1,257	1,179	1,571	1,473	1,886	1,768
5.00	1.00	19.64	18.86	491	471	982	943	1,473	1,414	1,964	1,886	2,455	2,357	2,946	2,828
6.00	1.00	28.27	27.49	707	687	1,414	1,374	2,120	2,061	2,827	2,749	3,534	3,436	4,241	4,123
7.00	1.00	38.49	37.71	962	943	1,925	1,885	2,887	2,828	3,849	3,771	4,811	4,713	5,774	5,656
8.00	1.00	50.27	49.49	1,257	1,237	2,513	2,474	3,770	3,711	5,027	4,949	6,283	6,186	7,540	7,423
10.0	1.00	78.54	77.76	1,964	1,944	3,927	3,888	5,891	5,832	7,854	7,776	9,818	9,719	11,781	11,663
12.0	1.38	113.1	111.6	2,828	2,790	5,655	5,581	8,483	8,371	11,310	11,162	14,138	13,952	16,965	16,742
14.0	1.38	153.9	152.4	3,849	3,810	7,697	7,621	11,546	11,431	15,394	15,242	19,243	19,052	23,091	22,862
16.0	1.38	201.1	199.6	5,027	4,990	10,053	9,981	15,080	14,971	20,106	19,962	25,133	24,952	30,159	29,942
18.0	2.00	254.5	251.4	6,362	6,284	12,724	12,568	19,085	18,852	25,447	25,136	31,809	31,420	38,171	37,704
20.0	2.00	314.2	311.1	7,854	7,776	15,708	15,553	23,562	23,329	31,416	31,106	39,270	38,882	47,124	46,659
22.0	2.50	380.1	375.2	9,503	9,380	19,007	18,760	28,510	28,140	38,013	37,520	47,516	46,900	57,020	56,280

“At JIT (Just-In-Time) Cylinders,

## Cylinder Weight Chart

The following chart is used to determine the weight of the cylinder(s). Please add an additional 40 lbs for packaging of cylinders whose weight is over 100 lbs.

Bore	Rod Dia	Weight at Zero Stroke	Weight per Inch of Stroke
2.50	0.63	10.2	0.6
3.25	1.00	15.4	0.8
4.00	1.00	23.6	1.0
5.00	1.00	35.3	1.1
6.00	1.00	51.1	1.6
7.00	1.00	67.5	2.0
8.00	1.00	125.9	2.6
10.0	1.00	174.0	3.3
12.0	1.38	269.8	3.8
14.0	1.38	374.4	5.9
16.0	1.38	491.5	6.9
18.0	2.00	753.6	10.0
20.0	2.00	973.2	12.2
22.0	2.50	1415.5	15.0

we supply

cylinder solutions for today's industrial applications. Being 100% employee owned

we work

as a team to solve our customers' requirements. Through this motivational approach,

we deliver

innovative and responsive cylinder application solutions. At the same time,

we support

your engineering, design and manufacturing teams. Though this approach

we build

our leadership and strengthen our business to ensure

we create

long term partnerships.”

## Warranty Service

### Warranty

JIT Cylinders, Inc. warrants every product of its manufacture to be of proper materials and first class workmanship. We agree to repair or replace, F.O.B. factory, but not to remove or install in the field, any perishable soft goods such as seals, which fail within a six-month period after shipment, normal wear accepted. We warrant for one year from date of shipment, all other parts which fail because of defective materials or workmanship. JIT assumes no responsibility for work done or expenses incurred, in the field, pertaining to such repairs or replacements, except upon written authority from our home office. Components not produced by JIT are subject only to the warranty extended to JIT by their respective manufacturer. When orders have been correctly filled, there shall be no returns without JIT's approval. Such returns will be subject to a restocking charge.

### Return Goods Authorization (RGA)

All returns to JIT Cylinders must be accompanied with a Return Goods Authorization Number. A Return Goods Authorization Number may be obtained by contacting the plant. JIT Cylinders will inquire into why the return is being made and a number will be assigned at that time. Paperwork will be completed by JIT Cylinders giving details of the return from the information supplied by the customer or distributor. At the time the return is received the RGA number will be matched to the proper paperwork. This allows entry of the return without further questions or delays.

### Quality Excellence Policy

We at JIT Cylinders are committed to serving the needs of our customers, as our name implies, Just-In-Time. We are committed to providing products and services which meet application requirements and are engineered for superior performance and reliability. We will achieve this through quality excellence in everything we do. Each task must be performed in conformance to requirements, and systems must be established which assure error-free performance in every area of manufacture. We understand that "quality excellence" depends on the personal performance of each employee. Because of this the entire management team and each member of manufacturing is dedicated and personally involved in the quality improvement process. We are dedicated to a policy of providing quality products and services that fully satisfy our customers' needs. We subscribe to the following quality absolutes:

*Quality is defined as 100 percent conformance to requirements.*

*Our performance goal is to achieve error-free work in all functional areas.*

*Our system for causing quality is prevention.*

*We will track our progress in achieving total quality by measuring the price of non-conformance (waste).*

*Our primary objective will be continuous improvement.*

### 100% Tested and Inspected!

Cylinders are first cycled at low pressure to remove air from the system and checked for proper mechanical action. During this procedure rod extension and stroke are measured. Test pressure is applied to cap and head ports in turn and under static pressure all joints are examined for leakage. Air lines are then fitted to cap and head in turn. The hydraulic fitting is removed from the non-pressurized port and a visual inspection made for air bubbles to indicate any piston seal leakage.

In addition, every cylinder is examined for:

Dimensional accuracy

Proper unit switch actuation (if applicable)

Visual inspection for freedom of defects

Proper assembly orientation