



CYLINDERS

The responsive solution

MH/ML Series

A detailed 3D rendering of a hydraulic cylinder, shown in a perspective view. The cylinder is grey and features a long, polished piston rod extending from the front. The front end shows the mounting bracket and the rod's attachment point. The background is a large, light grey circle on a darker grey background.

**Mill Duty
High Pressure
Hydraulic**

2201 Highway 31 S
Hartselle, AL 35640

tel **256.751.2548**
fax: **256.751.2189**

www.jitcylinders.com

2" to 16"
Multiple Mounting
Styles

JIT Cylinders MH/ML Series Catalog

Table of Contents

Introduction	Page 1
Model Code	2
Cylinder Options	3
No Mounts	4
Clevis Mounts	5
Spherical Mounts	6
Front Flange Mounts	7
Rear Flange Mounts	8
Side Lug Mounts	9
Trunnion Mounts	10
Standard Cylinder Accessories	11
Standard Cylinder Accessories	12
Standard Cylinder Accessories	13
Standard Cylinder Accessories	14
Replacement Seal Kits	15
Warranty	16
Pressure Ratings and Output Forces	17
Manufacturing Excellence	18
Company Profile	19

Just In Time Stocking Levels

Our proactive inventory strategy with reactive responses help maintain product levels that keep your equipment productive with the fastest deliveries of stocked products. Our broad and responsive inventory system has been designed with the end user in mind, not outside shareholders.

Development of the MH/ML Series

Each JIT product has been designed by the industry specifically for industry. We don't tell you what you want, we have asked what you want. Product design input has been and still is actively collected from engineers, maintenance professionals and even operators to ensure maximum cylinder effectiveness. Through this on going effort, customers now have access to a product that has been designed:

"By You, For You"

Introduction to Excellence

Engineered products and applications expertise with the assurance that interchangeable parts are available worldwide and backed by expert service. JIT (Just-In-Time) Cylinders designs, manufactures and markets hydraulic, electro-hydraulic, pneumatic and electro-pneumatic components which provide force and motion control for industrial applications. Our components have superior adaptability allowing our engineers to present responsive solutions to maximize performance levels for all unique types of industrial equipment.

Designed per Application

JIT Cylinders has many cylinder application engineers that cross the globe everyday trouble shooting harsh and critical cylinder applications. Coupled with JIT's extensive Fluid Power Repair divisions, we take pride in designing cylinders to your exact application requirements. No other cylinder company has the capabilities to provide the timely and cost effective cylinder solutions that JIT daily provides.

Product Training

Training is provided to help ensure your systems are working at maximum efficiency via new technologies and best practices.

Performance you expect:

JIT Cylinders have been extensively designed to produce the following competitive advantages:

- * *Longer lifetime of service*
- * *Minimal downtime*
- * *Fast and easy installation*
- * *Simple and affordable repairs*
- * *No special tools required to make repairs.*
- * *Lower operating cost*
- * *More options available*
- * *Expedited deliveries with no extra charges
(Why pay more for their inefficiencies?)*
- * *Dedicated service professionals on call*

Large Enough to Make a Difference; Small Enough to Know the Difference

We at JIT Cylinders supply solutions to problems rather than just product configurations. Each day we strive to improve our product performances by developing intelligent actuation capability.

MODEL CODE**MH/ML Series**

MH	MP1	4"	10"	2"	1	BE	S	P	S
<i>1</i>	<i>2</i>	<i>3</i>	<i>4</i>	<i>5</i>	<i>6</i>	<i>7</i>	<i>8</i>	<i>9</i>	<i>10</i>

1	Model Series
MH	High Pressure Hydraulic (2500 - 5000 psi)*
ML	Low Pressure Hydraulic (250 - 1500 psi)*

*Dependant on Mounting Style

2	Mounting Style (Pages 9-15)
MX0	No Mount
MP1	Fixed Cap Clevis
MPU3	Self Aligning Eye
MF1	Rect Head Flange
MF2	Rect Cap Flange
MS2	Side Lugs
MT4	Inter.Fixed Trunnion

* Other NFPA Mounts are available

3	Bore Size (2.5" - 16")
----------	-------------------------------

4	Stroke (.001" - 360")
----------	------------------------------

5	Rod Diameter (.625" - 10")
----------	-----------------------------------

6	Rod Threads
1	Small Male
2	Oversized Male
3	Standard Female
4	Safety Coupler
5	Special

7	Cushions
NC	Non Cushion
RE	Rod End
CE	Cap Ends
BE	Both Ends

8	Port Styles
S	SAE
N	NPT
F	Code 62
M	Metric

*Specify BSPP, BSPT

9	Seals
P	Polyurethane
B	Nitrile
V	Viton
L	Low Friction/High Load
H	Water Glycol Application
C	Cast Iron

10	Specials
	Air Bleeds
	Chromed Bore
	Controlled Piston Purge
	Electroless Nickel Plated Cylinders
	Special Paint
	Gland Drain
	Linear Transducer
	Metallic Rod Scrapers
	Mixed Mounting Styles
	Proximity Switches
	Rod Boot
	Special, Rotated, or Oversize Ports
	Stainless Steel Construction
	Stop Tube (Indicate Total Gross)
	Water Jacket

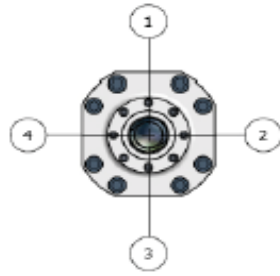

Cylinder Options

Gland Drain

When not even a drop of external leakage can be tolerated, a gland drain option will provide the signal (predictive maintenance) that the rod seal has worn to the point of replacement preventing the danger of contamination from leakage. The gland drain redirects any accumulated fluid, between the rod seal and wiper, back to the tank. Air models may be modified in the same way to permit lubrication of rod seal and inner bearing surfaces.

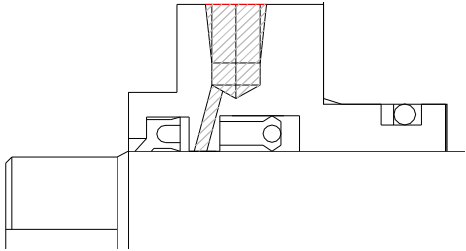

Stop Tube

Stop tubes reduce piston and bearing loads on long push stroking cylinders. A stop-tube increases the distance between the piston and rod bearing when the cylinder stroke is fully extended. This increased distance adds structural rigidity and helps prevent rod buckling. When ordering a cylinder with a stop-tube it is essential the stop-tube length, working stroke and total gross stroke be included.

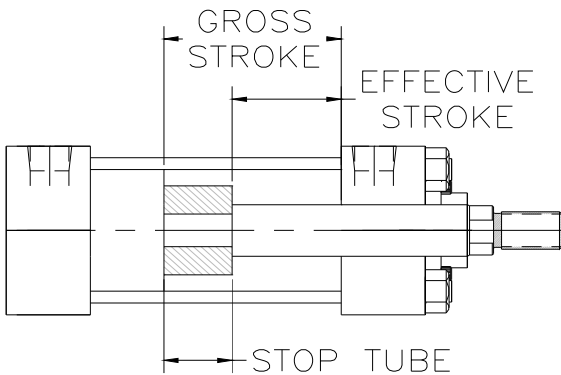

Adjustable Stroke

An integral stroke adjustment (externally adjusted) that is accomplished by the use of a bump rod threaded into the cylinder cap. Seals are incorporated to prevent external leakage, and a lock nut is included.

Stainless Steel Piston Rods

Many applications, especially those subjected to water spray, require the use of stainless steel piston rods. We furnish 17-4 pH hard chrome plated stainless steel, unless otherwise specified, which is considered a superior corrosion-resistant type of stainless steel. The minimum expected yield is 110,000 lb which should be considered with respect to operating pressure and column loading.

Proximity Switch

End of travel limit switches are available that signal rod position for control and safety circuits. The proximity switches for these cylinders are an inductive type switch with a sensing probe that "looks" at the cushion collar or spear providing full extension or full retraction indication.

Rod Boot

Rod-boots are used to protect the piston rod from harmful effects of severe operating environments. They are available for all cylinders. It is necessary to provide additional piston rod extension to allow space for the compressed rod boot length. The required extension varies with the rod diameter and stroke length.

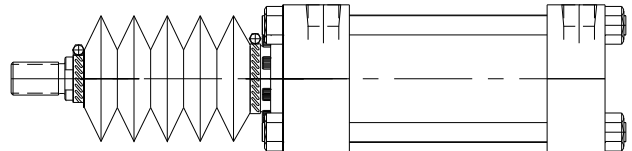

Air Bleed

Usually hydraulic cylinders will bleed themselves of air when ports are vertical, on top. Bleed ports are often desirable to remove entrapped air, for example, when the ports are on the bottom. High performance, high speed or heavy load applications are a few examples where air bleeds are also desirable.

MH/ML Series MX0 Mount

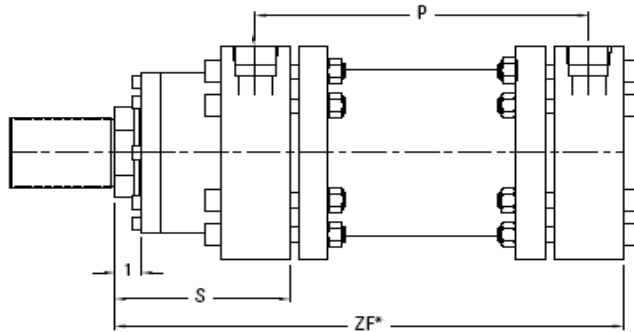
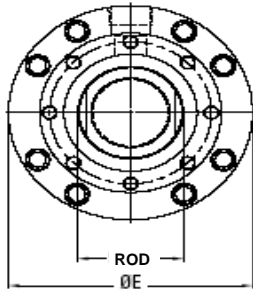

MH Series High Pressure Hydraulic

Bore	E	SAE	NPT	P*	ZF*	S
3	5.19	#8	1/2	5.38	10.50	5.13
4	6.50	#12	3/4	5.75	10.19	5.18
5	7.88	#12	3/4	7.00	13.75	6.75
6	9.25	#16	1	7.94	15.56	7.63
7	10.75	#20	1 1/4	8.63	17.38	8.75
8	12.38	#24	1 1/2	10.25	20.19	9.94
10	14.94	#32	2	10.50	21.94	11.94
12	17.50	#32	2 1/2	11.44	24.38	13.06
14	20.38	#32	2 1/2	11.56	25.75	14.19
16	23.38	#32	3	12.50	29.25	16.75

Eligible Rod Sizes

Bore	Std	Oversized		
3	1.75	2		
4	2	2.5		
5	2.5	3	3.5	
6	3	3.5	4	
7	3.5	4	4.5	5
8	4	4.5	5	5.5
10	5	5.5	7	
12	5.5	7	8	
14	7	8	10	
16	8	10		

ML Series Air and Low Pressure Hydraulic

Bore	E	NPT	SAE	P*	ZF*	S
2	3.88	1/2	#8	3.75	7.38	3.63
3	5.19	1/2	#8	4.25	7.88	3.63
4	6.25	3/4	#12	4.50	8.75	4.25
5	7.88	3/4	#12	5.50	11.38	5.88
6	9.25	1	#16	6.25	12.88	6.63
7	10.75	1 1/4	#20	6.38	13.63	7.25
8	12	1 1/2	#24	7.75	15.63	7.88
10	14.94	2	#32	9.25	17.44	8.19
12	17.19	2 1/2	#32	10.44	19.75	9.31
14	19.5	2 1/2	#32	10.69	21.50	10.81
16	23.38	3	#32	11.63	23.88	12.25

Eligible Rod Sizes

Bore	Std	Oversized		
2	1	1.375		
3	1.375	1.75	2	
4	1.75	2	2.5	
5	2.0	2.5	3	3.5
6	2.5	3	3.5	4
7	3.0	3.5	4	4.5
8	3.5	4	4.5	6
10	4.0	4.5	5	5.5
12	5.5	7	8	
14	7	8	10	
16	8	10		

MH/ML Series MP1 Mount

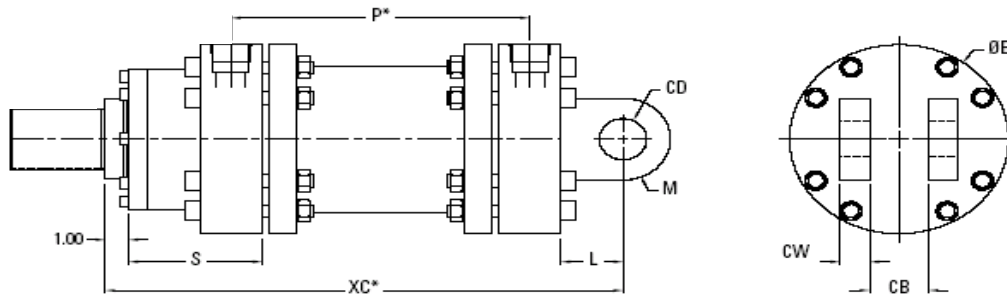

MH Series High Pressure Hydraulic

Bore	E	SAE	NPT	P*	XC*	S	M	CD	L	CW	CB
3	5.19	#8	1/2	5.38	12.00	5.13	1.00	1.00	1.50	0.75	1.50
4	6.50	#12	3/4	5.75	13.06	5.19	1.38	1.38	2.13	1.00	2.00
5	7.88	#12	3/4	7.00	16.00	6.75	1.75	1.75	2.25	1.25	2.50
6	9.25	#16	1	7.94	18.06	7.63	2.00	2.00	2.50	1.25	2.50
7	10.75	#20	1 1/4	8.63	20.38	8.75	2.50	2.50	3.00	1.50	3.00
8	12.38	#24	1 1/2	10.25	23.44	9.94	3.00	3.00	3.25	1.50	3.00
10	14.94	#32	2	10.50	26.44	11.94	3.50	3.50	4.00	2.00	4.00
12	17.50	#32	2 1/2	11.31	28.88	13.06	4.00	4.00	4.50	2.25	4.50
14	20.38	#32	2 1/2	11.56	31.50	14.19	5.00	5.00	5.75	3.00	6.00
16	23.38	#32	3	12.50	36.25	16.75	6.00	6.00	7.00	3.50	7.00

Eligible Rod Sizes

Bore	Std	Oversized		
3	1.75	2		
4	2	2.5		
5	2.5	3	3.5	
6	3	3.5	4	
7	3.5	4	4.5	5
8	4	4.5	5	5.5
10	5	5.5	7	
12	5.5	7	8	
14	7	8	10	
16	8	10		

ML Series Air and Low Pressure Hydraulic

Bore	E	NPT	SAE	P*	XC*	S	M	CD	L	CW	CB
2	3.88	1/2	#8	3.75	8.63	3.63	0.75	0.75	1.25	0.63	1.25
3	5.19	1/2	#8	4.25	9.38	3.63	1.00	1.00	1.50	0.75	1.50
4	6.25	3/4	#12	4.50	10.88	4.25	1.38	1.38	2.12	1.00	2.00
5	7.88	3/4	#12	5.50	13.63	5.88	1.75	1.75	2.25	1.25	2.50
6	9.25	1	#16	6.25	15.38	6.63	2.00	2.00	2.50	1.25	2.50
7	10.75	1 1/4	#20	6.38	16.63	7.25	2.50	2.50	3.00	1.50	3.00
8	12	1 1/2	#24	7.75	18.88	7.88	3.00	3.00	3.25	1.50	3.00
10	14.94	2	#32	9.25	21.44	8.19	3.50	3.50	4.00	2.00	4.00
12	17.19	2 1/2	#32	10.44	24.25	9.31	4.00	4.00	4.50	2.25	4.50
14	19.5	2 1/2	#32	10.69	27.25	10.81	5.00	5.00	5.75	3.00	6.00
16	23.38	3	#32	11.63	30.88	12.25	6.00	6.00	7.00	3.50	7.00

Eligible Rod Sizes

Bore	Std	Oversized		
2	1	1.38		
3	1.375	1.75	2	
4	1.75	2	2.5	
5	2.0	2.5	3	3.5
6	2.5	3	3.5	4
7	3.0	3.5	4	4.5
8	3.5	4	4.5	6
10	4.0	4.5	5	5.5
12	5.5	7	8	
14	7	8	10	
16	8	10		

MH/ML Series MPU3 Mount

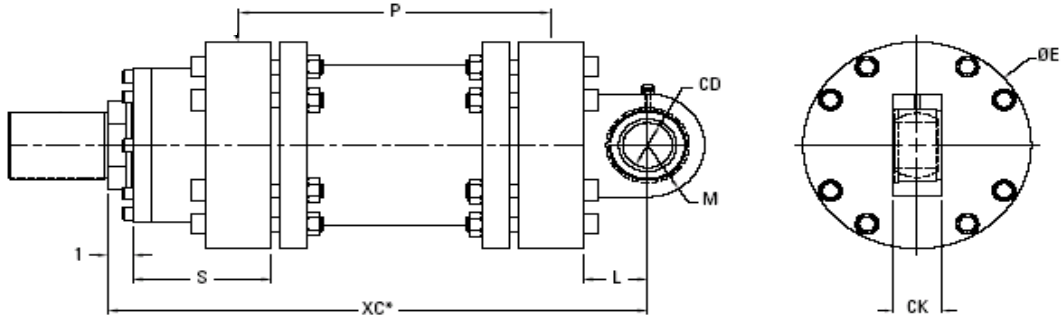

MH Series High Pressure Hydraulic

Bore	E	SAE	NPT	P*	XC*	S	M	CD	L	CK
3	5.19	#8	1/2	5.38	12.00	5.13	1.63	1.00	1.50	1.00
4	6.50	#12	3/4	5.75	13.06	5.19	1.75	1.38	2.13	1.50
5	7.88	#12	3/4	7.00	16.00	6.75	2.50	1.75	2.25	1.75
6	9.25	#16	1	7.94	18.06	7.63	2.88	2.00	2.50	2.00
7	10.75	#20	1 1/4	8.63	20.38	8.75	3.38	2.50	3.00	2.50
8	12.38	#24	1 1/2	10.25	23.44	9.94	3.88	3.00	3.25	3.00
10	14.94	#32	2	10.50	26.44	11.94	5.50	3.50	4.00	3.19
12	17.50	#32	2 1/2	11.31	28.88	13.06	6.00	4.00	4.50	3.50
14	20.38	#32	2 1/2	11.56	31.50	14.19	6.75	5.00	5.75	4.25
16	23.38	#32	3	12.50	36.25	16.75	7.50	6.00	7.00	4.63

Eligible Rod Sizes

Bore	Eligible Rod Sizes			
	Std	Oversized		
3	1.75	2		
4	2	2.5		
5	2.5	3	3.5	
6	3	3.5	4	
7	3.5	4	4.5	5
8	4	4.5	5	5.5
10	5	5.5	7	
12	5.5	7	8	
14	7	8	10	
16	8	10		

ML Series Air and Low Pressure Hydraulic

Bore	E	NPT	SAE	P*	XC*	S	M	CD	L	CK
2	3.88	1/2	#8	3.75	8.63	3.63	1.25	0.75	1.25	0.56
3	5.19	1/2	#8	4.25	9.38	3.63	1.63	1.00	1.50	1.00
4	6.25	3/4	#12	4.50	10.88	4.25	1.75	1.38	2.13	1.50
5	7.88	3/4	#12	5.50	13.63	5.88	2.50	1.75	2.25	1.75
6	9.25	1	#16	6.25	15.38	6.63	2.88	2.00	2.50	2.00
7	10.75	1 1/4	#20	6.38	16.63	7.25	3.38	2.50	3.00	2.50
8	12	1 1/2	#24	7.75	18.88	7.88	3.88	3.00	3.25	3.00
10	14.94	2	#32	9.25	21.44	8.19	5.50	3.50	4.00	3.19
12	17.19	2 1/2	#32	10.44	24.25	9.31	6.00	4.00	4.50	3.50
14	19.5	2 1/2	#32	10.69	27.25	10.81	5.75	5.00	5.75	4.25
16	23.38	3	#32	11.63	30.88	12.25	7.50	6.00	7.00	4.63

Eligible Rod Sizes

Bore	Eligible Rod Sizes			
	Std	Oversized		
2	1	1.375		
3	1.375	1.75	2	
4	1.75	2	2.5	
5	2.0	2.5	3	3.5
6	2.5	3	3.5	4
7	3.0	3.5	4	4.5
8	3.5	4	4.5	6
10	4.0	4.5	5	5.5
12	5.5	7	8	
14	7	8	10	
16	8	10		

MH/ML Series MF1 Mount

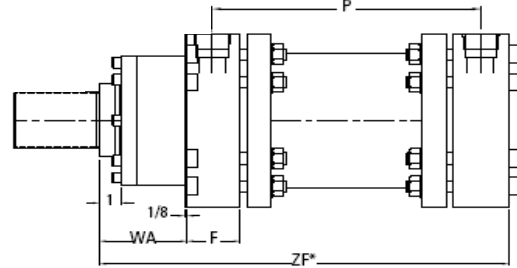
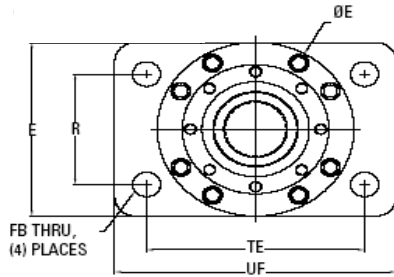

MH Series High Pressure Hydraulic

Bore	E	SAE	NPT	P*	ZF*	F	FB	R	TE	UF	BD	WA
3	5.19	#8	1/2	5.4	10.5	1.6	0.6	4.2	5.8	6.8	5.2	3.5
4	6.50	#12	3/4	5.8	10.2	1.6	0.7	5.3	7.2	8.4	6.3	3.6
5	7.88	#12	3/4	7.0	13.8	2.1	0.8	6.4	8.7	10.2	7.9	4.6
6	9.25	#16	1	7.9	15.6	2.5	1.1	7.3	10.3	12.3	9.3	5.1
7	10.75	#20	1 1/4	8.6	17.4	2.5	1.2	8.5	11.9	14.2	10.8	6.3
8	12.38	#24	1 1/2	10.3	20.2	3.4	1.3	9.9	13.7	16.2	12.0	6.6
10	14.94	#32	2	10.5	21.9	3.4	1.6	11.9	16.5	19.5	14.9	8.6
12	17.50	#32	2 1/2	11.3	24.4	3.7	1.8	14.0	19.3	22.8	17.2	9.4
14	20.38	#32	2 1/2	11.6	25.8	3.7	2.1	16.4	22.4	26.4	19.5	10.5
16	23.38	#32	3	12.5	29.3	4.1	2.3	18.9	25.7	30.2	23.0	12.6

Eligible Rod Sizes

Bore	Std	Oversized		
3	1.75	2		
4	2	2.5		
5	2.5	3	3.5	
6	3	3.5	4	
7	3.5	4	4.5	5
8	4	4.5	5	5.5
10	5	5.5	7	
12	5.5	7	8	
14	7	8	10	
16	8	10		

ML Series Air and Low Pressure Hydraulic

Bore	E	NPT	SAE	P*	ZF*	F	FB	R	TE	UF	BD	WA
2	3.88	1/2	#8	3.8	7.4	1.5	0.4	3.1	4.3	5.0	3.9	2.1
3	5.19	1/2	#8	4.3	7.9	1.6	0.6	4.2	5.8	6.8	5.2	2.0
4	6.25	3/4	#12	4.5	8.8	1.6	0.7	5.0	6.9	8.2	6.3	2.6
5	7.88	3/4	#12	5.5	11.4	2.1	0.8	6.4	8.7	10.2	7.9	3.8
6	9.25	1	#16	6.3	12.9	2.5	1.1	7.3	10.3	12.3	9.3	4.1
7	10.75	1 1/4	#20	6.4	13.6	2.5	1.2	8.4	11.9	14.2	10.8	4.8
8	12	1 1/2	#24	7.8	15.6	3.4	1.3	9.5	13.9	15.8	12.0	4.5
10	14.94	2	#32	9.3	17.4	3.4	1.6	11.9	16.5	19.5	14.9	4.8
12	17.19	2 1/2	#32	10.4	19.8	3.7	1.8	13.7	19.0	22.5	17.2	5.6
14	19.5	2 1/2	#32	10.7	21.5	3.7	2.1	15.5	21.6	25.6	19.5	7.1
16	23.38	3	#32	11.2	23.9	4.1	2.3	18.9	25.7	30.2	23.0	8.1

Eligible Rod Sizes

Bore	Std	Oversized		
2	1	1.375		
3	1.375	1.75	2	
4	1.75	2	2.5	
5	2.0	2.5	3	3.5
6	2.5	3	3.5	4
7	3.0	3.5	4	4.5
8	3.5	4	4.5	6
10	4.0	4.5	5	5.5
12	5.5	7	8	
14	7	8	10	
16	8	10		

MH/ML Series MF2 Mount

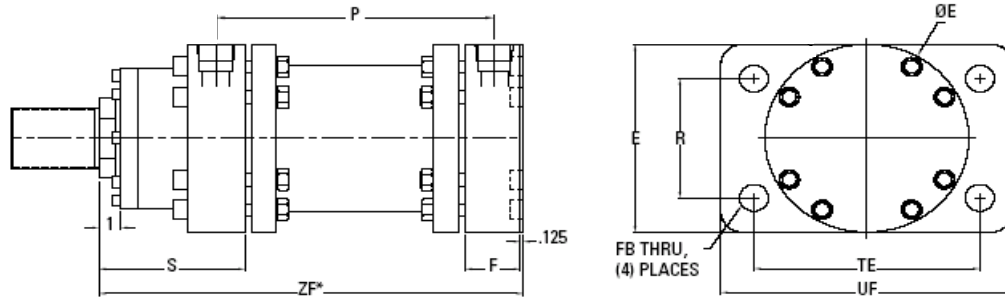

MH Series High Pressure Hydraulic

Bore	E	SAE	NPT	P*	ZF*	F	FB	R	TE	UF	BD	S
3	5.19	#8	1/2	5.4	10.5	1.6	0.6	4.2	5.8	6.8	5.2	5.1
4	6.50	#12	3/4	5.8	10.2	1.6	0.7	5.3	7.2	8.4	6.3	5.2
5	7.88	#12	3/4	7.0	13.8	2.1	0.8	0.4	8.7	10.2	7.9	6.8
6	9.25	#16	1	7.9	15.6	2.5	1.1	7.3	10.3	12.3	9.3	7.6
7	10.75	#20	1 1/4	8.6	17.4	2.5	1.2	8.5	11.9	14.2	10.8	8.8
8	12.38	#24	1 1/2	10.3	20.2	3.4	1.3	9.9	13.7	16.2	12.0	9.9
10	14.94	#32	2	10.5	21.9	3.4	1.6	11.9	16.5	19.5	14.9	11.9
12	17.50	#32	2 1/2	11.3	24.4	3.7	1.8	14.0	19.3	22.8	17.2	13.1
14	20.38	#32	2 1/2	11.6	25.8	3.7	2.1	16.4	22.4	26.4	19.5	14.2
16	23.38	#32	3	12.5	29.3	4.1	2.3	18.9	25.7	30.2	23.0	16.8

Eligible Rod Sizes

Bore	Std	Oversized		
3	1.75	2		
4	2	2.5		
5	2.5	3	3.5	
6	3	3.5	4	
7	3.5	4	4.5	5
8	4	4.5	5	5.5
10	5	5.5	7	
12	5.5	7	8	
14	7	8	10	
16	8	10		

ML Series Air and Low Pressure Hydraulic

Bore	E	NPT	SAE	P*	ZF*	F	FB	R	TE	UF	BD	S
2	3.88	1/2	#8	3.8	7.4	1.5	0.4	3.1	4.3	5.0	3.9	3.6
3	5.19	1/2	#8	4.3	7.9	1.6	0.6	4.2	5.8	6.8	5.2	3.6
4	6.25	3/4	#12	4.5	8.8	1.6	0.7	5.0	6.9	8.2	6.3	4.3
5	7.88	3/4	#12	5.5	11.4	2.1	0.8	6.4	8.7	10.2	7.9	5.9
6	9.25	1	#16	6.3	12.9	2.5	1.1	7.3	10.3	12.3	9.3	6.6
7	10.75	1 1/4	#20	6.4	13.6	2.5	1.2	8.4	11.9	14.2	10.8	7.3
8	12	1 1/2	#24	7.8	15.6	3.4	1.3	9.5	13.9	15.8	12.0	7.9
10	14.94	2	#32	9.3	17.4	3.4	1.6	11.9	16.5	19.5	14.9	8.2
12	17.19	2 1/2	#32	10.4	19.8	3.7	1.8	13.7	19.0	22.5	17.2	9.3
14	19.5	2 1/2	#32	10.7	21.5	3.7	2.1	15.5	21.6	25.6	19.5	10.8
16	23.38	3	#32	11.2	23.9	4.1	2.3	18.9	25.7	30.2	23.0	12.3

Eligible Rod Sizes

Bore	Std	Oversized		
2	1	1.375		
3	1.375	1.75	2	
4	1.75	2	2.5	
5	2.0	2.5	3	3.5
6	2.5	3	3.5	4
7	3.0	3.5	4	4.5
8	3.5	4	4.5	6
10	4.0	4.5	5	5.5
12	5.5	7	8	
14	7	8	10	
16	8	10		

MH/ML Series MS2 Mount

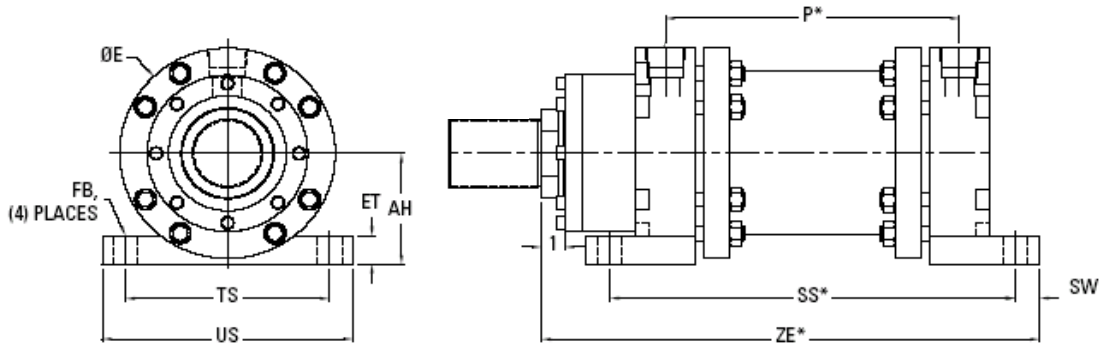

MH Series High Pressure Hydraulic

Bore	E	SAE	NPT	P*	ZE*	SS*	SW	FB	US	TS	ET	AH
3	5.19	#8	1/2	5.38	11.50	8.13	0.50	0.56	6.56	5.56	0.75	2.84
4	6.50	#12	3/4	5.75	12.19	8.75	0.63	0.69	8.13	6.88	1.00	3.50
5	7.88	#12	3/4	7.00	15.25	10.75	0.75	0.81	9.75	8.25	1.13	4.19
6	9.25	#16	1	7.94	17.56	12.56	1.00	1.06	11.63	9.63	1.50	4.88
7	10.75	#20	1 1/4	8.63	19.63	13.50	1.13	1.19	13.38	11.13	1.75	5.63
8	12.38	#24	1 1/2	10.25	22.69	16.25	1.25	1.31	15.38	12.75	1.88	6.44
10	14.94	#32	2	10.50	25.44	17.00	1.50	1.56	18.31	15.31	2.25	7.78
12	17.50	#32	2 1/2	11.31	27.88	18.63	1.75	1.81	21.63	17.88	2.63	9.13
14	20.38	#32	2 1/2	11.56	29.75	19.38	2.00	1.06	24.75	20.75	3.00	10.69
16	23.38	#32	3	12.50	33.75	21.25	2.25	2.31	28.25	23.75	3.38	12.44

Eligible Rod Sizes

Bore	Std	Oversized		
3	1.75	2		
4	2	2.5		
5	2.5	3	3.5	
6	3	3.5	4	
7	3.5	4	4.5	5
8	4	4.5	5	5.5
10	5	5.5	7	
12	5.5	7	8	
14	7	8	10	
16	8	10		

ML Series Air and Low Pressure Hydraulic

Bore	E	NPT	SAE	P*	ZE*	SS*	SW	FB	US	TS	ET	AH
2	3.88	1/2	#8	3.75	8.13	6.13	0.38	0.41	5.06	4.25	0.63	2.19
3	5.19	1/2	#8	4.25	8.88	7.00	0.50	0.56	6.56	5.56	0.75	2.84
4	6.25	3/4	#12	4.50	10.00	7.50	0.63	0.69	7.88	6.63	1.00	3.38
5	7.88	3/4	#12	5.50	12.88	9.24	0.75	0.81	9.75	8.25	1.13	4.19
6	9.25	1	#16	6.25	14.88	10.88	1.00	1.06	11.63	9.63	1.50	4.88
7	10.75	1 1/4	#20	6.38	16.00	11.38	1.13	1.19	13.25	11.13	1.75	5.63
8	12	1 1/2	#24	7.75	18.13	13.75	1.25	1.31	14.88	12.38	1.88	6.25
10	14.94	2	#32	9.25	20.44	15.75	1.50	1.56	18.31	15.31	2.25	7.78
12	17.19	2 1/2	#32	10.44	23.25	17.75	1.75	1.81	21.06	17.56	2.63	9.13
14	19.5	2 1/2	#32	10.69	25.25	18.50	2.00	2.06	23.88	19.88	3.00	10.50
16	23.38	3	#32	11.19	28.38	20.38	2.25	2.31	28.25	23.75	3.38	12.44

Eligible Rod Sizes

Bore	Std	Oversized		
2	1	1.375		
3	1.375	1.75	2	
4	1.75	2	2.5	
5	2.0	2.5	3	3.5
6	2.5	3	3.5	4
7	3.0	3.5	4	4.5
8	3.5	4	4.5	6
10	4.0	4.5	5	5.5
12	5.5	7	8	
14	7	8	10	
16	8	10		

MH/ML Series MT4 Mount

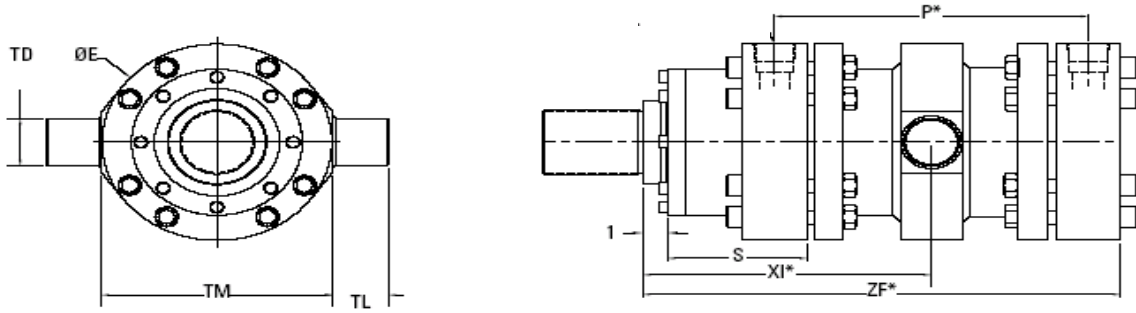

MH Series High Pressure Hydraulic

Eligible Rod Sizes

Bore	E	SAE	NPT	P*	ZF*	S	TM	TL	TD
3	5.19	#8	1/2	5.38	10.50	5.13	5.25	1.50	1.50
4	6.50	#12	3/4	5.75	10.81	5.19	6.56	1.75	1.75
5	7.88	#12	3/4	7.00	13.75	6.75	7.94	2.25	2.25
6	9.25	#16	1	7.94	15.56	7.63	9.31	2.50	2.50
7	10.75	#20	1 1/4	8.63	17.38	8.75	10.81	3.00	3.00
8	12.38	#24	1 1/2	10.25	20.19	9.94	12.44	3.50	3.50
10	14.94	#32	2	10.50	21.94	11.94	15.00	4.00	4.00
12	17.50	#32	2 1/2	11.31	24.38	13.06	17.56	5.00	5.00
14	20.38	#32	2 1/2	11.56	25.75	14.19	20.44	5.50	5.50
16	23.38	#32	3	12.50	29.25	16.75	23.44	6.50	6.50

Bore	Std	Oversized		
3	1.75	2		
4	2	2.5		
5	2.5	3	3.5	
6	3	3.5	4	
7	3.5	4	4.5	5
8	4	4.5	5	5.5
10	5	5.5	7	
12	5.5	7	8	
14	7	8	10	
16	8	10		

ML Series Air and Low Pressure Hydraulic

Eligible Rod Sizes

Bore	E	NPT	SAE	P*	ZF*	S	TM	TL	TD
2	3.88	1/2	#8	3.75	7.38	3.63	3.94	1.25	1.25
3	5.19	1/2	#8	4.25	7.88	3.63	5.25	1.38	1.38
4	6.25	3/4	#12	4.50	8.75	4.25	6.31	1.75	1.75
5	7.88	3/4	#12	5.50	11.38	5.88	7.94	2.00	2.00
6	9.25	1	#16	6.25	12.88	6.63	9.94	2.25	2.25
7	10.75	1 1/4	#20	6.38	13.63	7.25	10.81	2.38	2.38
8	12	1 1/2	#24	7.75	15.63	7.88	12.06	2.50	2.50
10	14.94	2	#32	9.25	17.44	8.19	15.00	3.00	3.00
12	17.19	2 1/2	#32	10.44	19.75	9.31	17.25	3.50	3.50
14	19.5	2 1/2	#32	10.69	21.50	10.81	19.56	4.50	4.50
16	23.38	3	#32	11.19	23.88	12.25	23.44	5.00	5.00

Bore	Std	Oversized		
2	1	1.38		
3	1.375	1.75	2	
4	1.75	2	2.5	
5	2.0	2.5	3	3.5
6	2.5	3	3.5	4
7	3.0	3.5	4	4.5
8	3.5	4	4.5	6
10	4.0	4.5	5	5.5
12	5.5	7	8	
14	7	8	10	
16	8	10		

Standard Accessories

Rod Clevis

Part No	Rod Dia	KK	CD	CB	CW	CE	A	ER
RC044	5/8	7/16-20	0.50	0.77	0.50	1.50	0.75	0.50
RC050	5/8	1/2-20	0.50	0.77	0.50	1.50	0.75	0.50
RC075	1	3/4-16	0.75	1.27	0.63	2.38	1.13	0.75
RC087	1	7/8-14	1.00	1.52	0.75	2.94	1.63	1.00
RC100	1 3/8	1-14	1.00	1.52	0.75	3.13	1.63	1.00
RC125	1 3/8	1 1/4-12	1.38	2.03	1.00	4.13	2.00	1.38
RC150	2	1 1/2-12	1.75	2.53	1.25	4.50	2.25	1.75
RC175	2	1 3/4-12	2.00	2.53	1.25	5.50	3.00	2.00
RC187	2 1/2	1 7/8-12	2.00	2.53	1.25	5.50	3.00	2.00
RC225	3	2 1/4-12	2.50	3.03	1.50	6.50	3.50	2.50
RC250	3 1/2	2 1/2-12	3.00	3.03	1.50	6.75	3.50	2.75
RC275	4	3-12	3.50	4.03	2.00	8.50	4.50	3.50
RC325	4 1/2	3 1/4-12	3.50	4.03	2.00	8.50	4.50	3.50
RC350	5	3 1/2-12	3.50	4.03	2.00	8.50	4.50	3.50
RC400	5 1/2	4-12	4.00	4.53	2.25	10.00	5.50	4.00

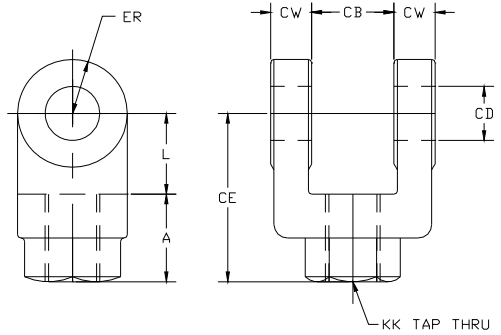

Rod Eye

Part No	Rod Dia	KK	CD	CB	CA	A	ER
FE044	5/8	7/16-20	0.50	0.75	1.50	0.75	0.63
FE050	5/8	1/2-20	0.50	0.75	1.50	0.75	0.63
FE075	1	3/4-16	0.75	1.25	2.06	1.13	0.88
FE087	1	7/8-14	1.00	1.50	2.38	1.13	1.44
FE100	1	1-14	1.00	1.50	2.81	1.63	1.19
FE125	1 3/8	1 1/4-12	1.38	2.00	3.44	2.00	1.56
FE150	1 3/4	1 1/2-12	1.75	2.50	4.00	2.25	2.00
FE175	2	1 3/4-12	2.00	2.50	4.38	2.25	2.88
FE187	2 1/2	1 7/8-12	2.00	2.50	5.00	3.00	2.50
FE225	2 1/2	2 1/4-12	2.50	3.00	5.81	3.50	2.81
FE250	3 1/2	2 1/2-12	3.00	3.00	6.13	3.50	3.25
FE275	4	3-12	3.50	4.00	7.63	4.50	3.88
FE325	4 1/2	3 1/4-12	3.50	4.00	7.63	4.50	3.88
FE350	5	3 1/2-12	3.50	4.00	7.63	5.00	3.88
FE400	5 1/2	4-12	4.00	4.50	9.13	5.50	4.44

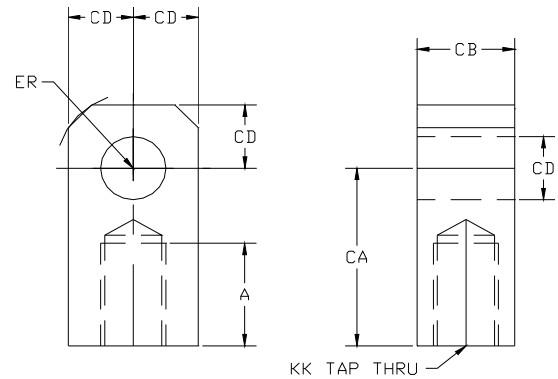

Pivot Pin

Part No.	CL	CD	A	D	E	CL	B
PP050	1.88	0.50	0.47	0.04	0.11	1.88	2.09
PP075	2.63	0.75	0.70	0.05	0.13	2.63	2.88
PP100	3.13	1.00	0.94	0.05	0.13	3.13	3.38
PP138	4.19	1.38	1.29	0.06	0.15	4.19	4.49
PP175	5.19	1.75	1.65	0.07	0.18	5.19	5.55
PP200	5.19	2.00	1.89	0.09	0.22	5.19	5.55
PP250	6.19	2.50	2.36	0.10	0.27	6.19	6.63
PP300	6.25	3.00	2.84	0.12	0.36	6.25	6.78
PP350	8.13	3.50	3.32	0.12	0.36	8.13	8.85
PP400	9.13	4.00	3.79	4.00	4.00	9.13	9.85

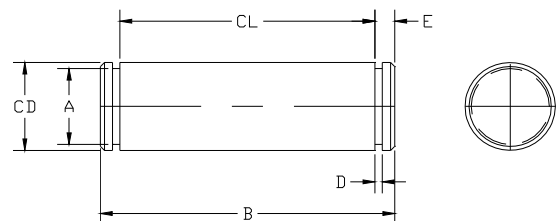

Pivot Pin furnished with (2) retainers.

Standard Accessories

Eye Bracket (High Pressure Hydraulic)

Part	H	Dimensions								
Number	Series	CD	CB	DD	E	F	FL	LR	M	R
EB050	1.50	0.50	0.75	0.41	2.50	0.38	1.13	0.75	0.50	1.63
EB075	2.0-2.5	0.75	1.25	0.53	3.50	0.63	1.88	1.25	0.75	2.56
EB100	3.25	1.00	1.50	0.66	4.50	0.75	2.25	1.50	1.00	3.25
EB138	4.00	1.38	2.00	0.66	5.00	0.88	3.00	2.13	1.38	3.81
EB175	5.00	1.75	2.50	0.91	6.50	0.88	3.13	2.25	1.75	4.95
EB200	6.00	2.00	2.50	1.06	7.50	1.00	3.50	2.50	2.00	5.75
EB250	7.00	2.50	3.00	1.19	8.50	1.00	4.00	3.00	2.50	6.59
EB300	8.00	3.00	3.00	1.31	9.50	1.00	4.25	3.25	3.00	7.50

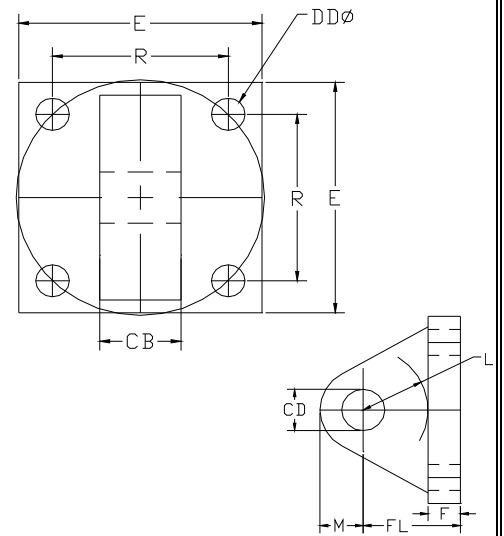

Eye Bracket (Air and Medium Pressure Hydraulic)

Part	A & LH	Dimensions								
Number	Series	CD	CB	DD	E	F	FL	LR	M	R
EB050	1.5-2.5	0.50	0.75	0.41	2.50	0.38	1.13	0.75	0.50	1.63
EB075	3.25-5	0.75	1.25	0.53	3.50	0.63	1.88	1.25	0.75	2.56
EB100	6-8	1.00	1.50	0.66	4.50	0.75	2.25	1.50	1.00	3.25

Clevis Bracket (High Pressure Hydraulic)

Part	H	Dimensions								
Number	Series	CD	CB	BA	CW	DD	E	F	FL	M
CB050	1.50	0.50	0.77	1.63	0.50	3/8-24	2.50	0.38	1.13	0.50
CB075	2.0-2.5	0.75	1.27	2.56	0.63	1/2-20	3.50	0.63	1.88	0.75
CB100	3.25	1.00	1.52	3.25	0.75	5/8-18	4.50	0.75	2.25	1.00
CB138	4.00	1.38	2.03	3.81	1.00	5/8-18	5.00	0.88	3.00	1.38
CB175	5.00	1.75	2.53	4.94	1.25	7/8-14	6.50	0.88	3.13	1.75
CB200	6.00	2.00	2.53	5.75	1.25	1-14	7.50	1.00	3.50	2.00
CB250	7.00	2.50	3.03	6.59	1.50	1 1/8-12	8.50	1.00	4.00	2.50
CB300	8.00	3.00	3.03	7.50	1.50	1 1/4-12	9.50	1.00	4.25	2.75

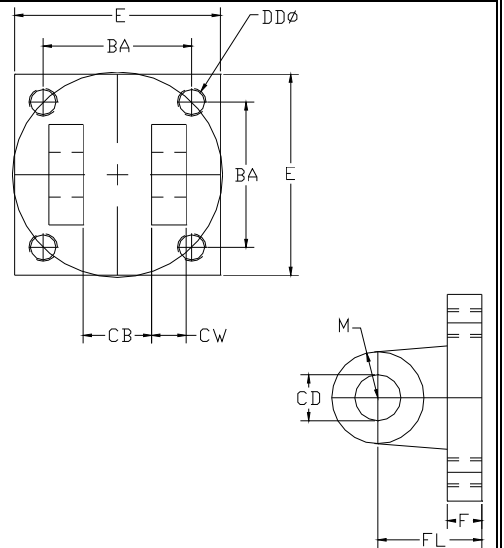

Clevis Bracket (Air and Medium Pressure Hydraulic)

Part	A & LH	Dimensions								
Number	Series	CD	CB	BA	CW	DD	E	F	FL	M
CB050	1.5-2.5	0.50	0.77	1.63	0.50	3/8-24	2.50	0.38	1.13	0.50
CB075	4-12	0.75	1.27	2.56	0.63	1/2-20	3.50	0.63	1.88	0.75
CB100	6-8	1.00	1.52	3.25	0.75	5/8-18	4.50	0.75	2.25	1.00

ALIGNMENT COUPLER

Part	DIMENSIONS							
Number	A	B	C	D	E	F	G	H
AC044	7/16-20	1.25	2.00	0.50	0.75	0.63	0.56	1.13
AC050	1/2-20	1.25	2.00	0.50	0.75	0.63	0.56	1.13
AC075	3/4-16	1.75	2.31	0.31	1.13	0.97	0.88	1.50
AC087	7/8-14	1.75	2.31	0.31	1.13	0.97	0.88	1.50
AC100	1-14	2.50	2.94	0.50	1.63	1.38	1.25	2.25
AC125	1 1/4-12	2.50	2.94	0.50	1.63	1.38	1.25	2.25
AC150	1 1/2-12	3.25	4.38	0.81	2.25	1.75	1.50	3.00
AC175	1 3/4-12	3.25	4.38	0.81	2.25	1.75	1.50	3.00
AC187	1 7/8-12	3.75	5.44	0.69	3.00	2.25	1.88	3.50
AC225	2 1/4-12	6.75	6.38	3.25	3.50	2.75	2.38	2.88
AC250	2 1/2-12	7.00	6.50	4.00	3.50	3.25	2.88	3.38

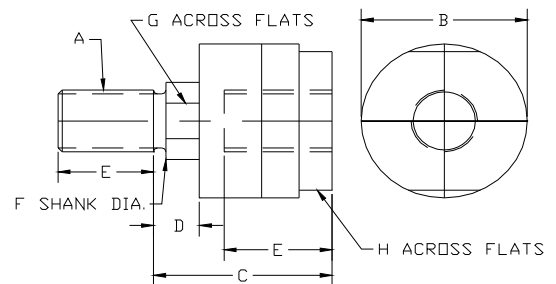

Standard Accessories

SELF-ALIGNING ROD END (High Pressure Hydraulic)

Part	H	DIMENSIONS							
Number	Series	KK	A	CD	CE	EX	ER	LE	JL
SAE044	1.50	7/16-20	0.69	0.50	0.88	0.44	0.88	0.75	0.88
SAE075	2.0-2.5	3/4-16	1.00	0.75	1.25	0.03	1.25	1.06	1.31
SAE100	3.25	1-14	1.50	1.00	1.88	0.88	1.38	1.44	1.50
SAE125	4.00	1 1/4-12	2.00	1.38	2.13	1.19	1.81	1.88	2.00
SAE150	5.00	1 1/2-12	2.13	1.75	2.50	1.53	2.19	2.13	2.25
SAE187	6.00	1 7/8-12	2.88	2.00	2.75	1.75	2.63	2.50	2.75

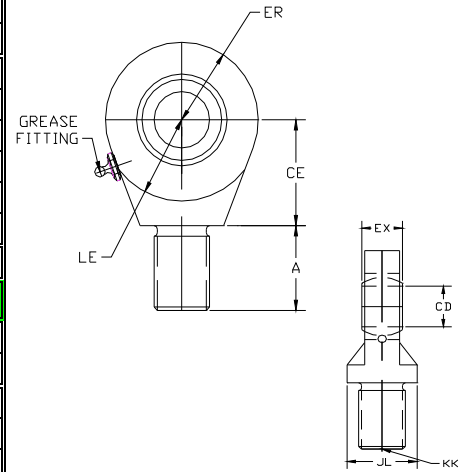

SELF-ALIGNING ROD END (Pneumatic and Low Pressure Hydraulic)

Part	A & LH	DIMENSIONS							
Number	Series	KK	A	CD	CE	EX	ER	LE	JL
SAE044	1.5-2.5	7/16-20	0.69	0.50	0.88	0.44	0.88	0.75	0.88
SAE075	3.25-5	3/4-16	1.00	0.75	1.25	0.03	1.25	1.06	1.31
SAE100	6-8	1-14	1.50	1.00	1.88	0.88	1.38	1.44	1.50

SELF-ALIGNING CLEVIS BRACKET

Part	H	DIMENSIONS								
Number	Series	CD	E	F	M	R	CF	CW	DD	FL
SCB050	1.50	0.50	3.00	0.50	0.50	2.05	0.44	0.50	0.41	1.50
SCB075	2.0-2.5	0.75	3.75	0.62	0.88	2.76	0.66	0.62	0.53	2.00
SCB100	3.25	1.00	5.50	0.75	1.00	4.10	0.88	0.75	0.53	2.50
SCB137	4.00	1.38	6.50	0.88	1.38	4.95	1.19	1.00	0.66	3.50
SCB175	5.00	1.75	8.50	1.25	1.75	6.58	1.53	1.25	0.91	4.50
SCB200	6.00	2.00	10.62	1.50	2.00	7.92	1.75	1.50	0.91	5.00

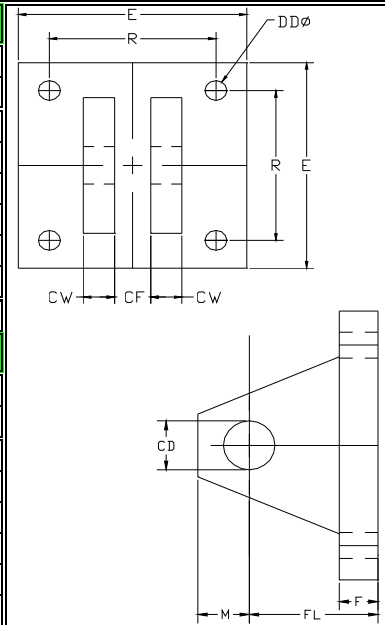

SELF-ALIGNING CLEVIS BRACKET

Part	A & LH	DIMENSIONS								
Number	Series	CD	E	F	M	R	CF	CW	DD	FL
SCB050	3-12	0.50	3.00	0.50	0.50	2.05	0.44	0.50	0.41	1.50
SCB075	3.25-5	0.75	3.75	0.62	0.88	2.76	0.66	0.62	0.53	2.00
SCB100	6-8	1.00	5.50	0.75	1.00	4.10	0.88	0.75	0.53	2.50
SCB137	4-12	1.38	6.50	0.88	1.38	4.95	1.19	1.00	0.66	3.50
SCB175		1.75	8.50	1.25	1.75	6.58	1.53	1.25	0.91	4.50
SCB200		2.00	10.62	1.50	2.00	7.92	1.75	1.50	0.91	5.00

SA PIVOT PINS

Part	H	A & LH	DIMENSIONS	
Number	Series	Series	CD	CL
PP050SA	1.50	1.5-2.5	0.500	1.56
PP075SA	2.0-2.5	3.25-5	0.750	2.03
PP100SA	3.25	6-8	1.000	2.50
PP138SA	4.00		1.374	3.31
PP175SA	5.00		1.750	4.22
PP200SA	6.00		2.000	4.94

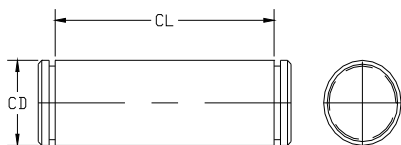

Pivot Pin furnished with (2) retainers.



The JIT Certified Guarantee

We guarantee that all cylinders ordered from this catalog will be built to the exact dimensions specified. All dimensions have been certified to be correct, and thus it is not necessary to request certified drawings.

Standard Accessories

Safety Coupler

Safety Couplers create a stronger connection than a standard threaded rod end and provide closer radial alignment making installation quicker and results in less wear of component parts by allowing for radial misalignment. Some additional Safety Coupler advantages include:

1. *Faster close radial alignment important for long cylinder life*
2. *Less critical rod end to machine attachment*
3. *Use with any JIT cylinder with 5/8" or larger rod diameter*
4. *Use with no extra cost JIT Style 4 rod end*
5. *Faster cylinder installation and removal*
6. *Better force distribution on push and pull strokes*
7. *For use with fixed mount cylinders*

Part No.	Rod Dia	Dimensions									
		B	C	D	H	I	J	L	M	N	P
SC062	0.63	0.41	1.50	0.56	45°	90°	0.22	4	1.13	0.25	0.66
SC100	1.00	0.75	2.00	0.88	30°	60°	0.28	6	1.50	0.38	1.06
SC138	1.38	0.94	2.50	1.00	30°	60°	0.34	6	2.00	0.38	1.44
SC175	1.75	1.19	3.00	1.25	22.5°	45°	0.34	8	2.38	0.50	1.81
SC200	2.00	1.44	3.50	1.63	15°	30°	0.41	12	2.69	0.63	2.06
SC250	2.50	1.88	4.00	2.88	15°	30°	0.41	12	3.19	0.75	2.63
SC300	3.00	2.38	5.00	2.38	15°	30°	0.53	12	4.00	0.88	3.13
SC350	3.50	2.63	5.88	2.63	15°	30°	0.66	12	4.69	1.00	3.63
SC400	4.00	3.13	6.38	2.63	15°	30°	0.66	12	5.19	1.00	4.13
SC450	4.50	3.63	6.88	3.13	15°	30°	0.66	12	5.69	1.50	4.63
SC500	5.00	4.00	7.38	3.13	15°	30°	0.66	12	6.19	1.50	5.13
SC550	5.50	4.50	8.25	3.88	15°	30°	0.78	12	6.88	1.88	5.63

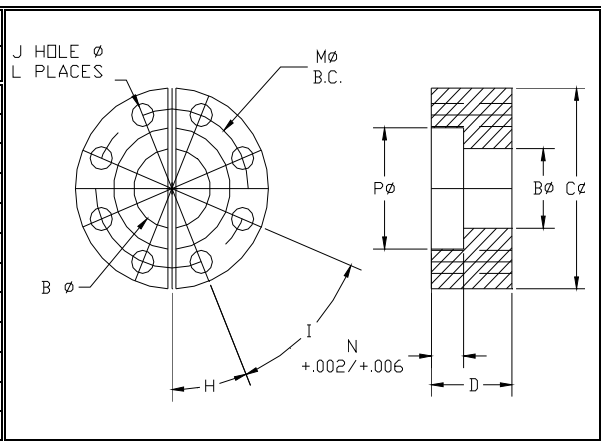

Weld Plate

Also available as a convenient accessory Coupler. The Weld Plate provides the ideal and tapped, properly sized plate to be welded to the hole in the machine. The Weld Plate is designed to facilitate fast, close tolerance positioning.

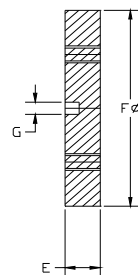
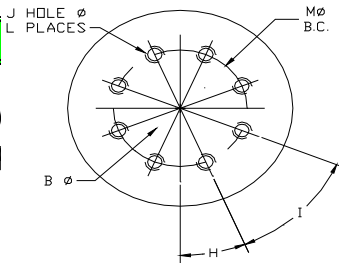

Weld Plate

Weld Plate to match each Safety Coupler. Offer to weld a pre-drilled and tapping each locator pin hole to match each Safety Coupler option include:

Part No.	Size	E	F	G	H	I	K	L	M
WP062	0.63	0.50	2.00	0.25	45°	90°	10-24	4	1.13
WP100	1.00	0.50	2.50	0.25	30°	60°	1/4-20	6	1.50
WP137	1.38	0.63	3.00	0.25	30°	60°	5/16-18	6	2.00
WP175	1.75	0.63	4.00	0.25	22.5°	45°	5/16-18	8	2.38
WP200	2.00	0.75	4.00	0.38	15°	30°	3/8-16	12	2.69
WP250	2.50	0.75	4.50	0.38	15°	30°	3/8-16	12	3.19
WP300	3.00	1.00	5.50	0.38	15°	30°	1/2-13	12	4.00
WP350	3.50	1.00	7.00	0.38	15°	30°	5/8-11	12	4.69
WP400	4.00	1.00	7.00	0.38	15°	30°	5/8-11	12	5.19
WP450	4.50	1.00	8.00	0.38	15°	30°	5/8-11	12	5.69
WP500	5.00	1.00	8.00	0.38	15°	30°	5/8-11	12	6.19
WP550	5.50	1.25	9.00	0.38	15°	30°	3/4-10	12	6.88

Sealing Solutions and Replacement Seal Kits

MH/ML Series

SEAL REPLACEMENT

Our gland design allows all rod seals, wipers, 'O' rings, and back-up washers to be easily removed from every standard gland regardless of rod size. Note that Gland Seal Kits have all seals properly loaded into a JIT Cylinders gland.

Polyurethane

Polyurethane seals are standard for H series cylinders.

Nitrile

Nitrile seals can be supplied for any bore size. The recommended operating temperature range is 10 degrees F. (23 degrees C.) to +165 degrees F. (+74 degrees C).

Viton Seals

Viton seals can be supplied for any bore size. Viton is suitable for higher temperature requirements within a range of 10 degrees F. (23 degrees C) to +250 degrees F. (+121 degrees C).

Custom Sealing Solution

JIT Cylinders designs and supplies sealing solutions for the most demanding applications. From exotic operating mediums to extremely high or low temperatures and pressures, we can design and manufacture cylinders that can operate effectively within almost any environment. Contact our engineering department to discuss your unique applications as we strive to supply responsive solutions to solve your application requirements.

High Pressure Hydraulic Seal Kits Sample

Rod Diameter	Standard		Viton	
	Gland Kit	Rod Seal Kit	Gland Kit	Rod Seal Kit
0.625	KMHG06	KMHR06	KMHGV06	KMHRV06
1	KMHG10	KMHR10	KMHGV10	KMHRV10
1.375	KMHG13	KMHR13	KMHGV13	KMHRV13
1.75	KMHG17	KMHR17	KMHGV17	KMHRV17
2	KMHG20	KMHR20	KMHGV20	KMHRV20
2.5	KMHG25	KMHR25	KMHGV25	KMHRV25
3	KMHG30	KMHR30	KMHGV30	KMHRV30
3.5	KMHG35	KMHR35	KMHGV35	KMHRV35
4	KMHG40	KMHR40	KMHGV40	KMHRV40
4.5	KMHG45	KMHR45	KMHGV45	KMHRV45

Barrel Bore	Standard	Viton
	Piston Kit	Piston Kit
1.5	KMHP15	KMHPV15
2	KMHP20	KMHPV20
2.5	KMHP25	KMHPV25
3.25	KMHP32	KMHPV32
4	KMHP40	KMHPV40
5	KMHP50	KMHPV50
6	KMHP60	KMHPV60
7	KMHP70	KMHPV70
8	KMHP80	KMHPV80

Contents of Standard Seal Kit

Gland Seal Kit
Gland
Rod Seal
Rod Wiper
Gland O.D. Seal
O.D. Backup

Rod Seal Kit
Rod Seal
Rod Wiper
Gland O.D. Seal
O.D. Backup

Piston Seal Kit
Piston Seals (2)
Barrel Seals (2)

Warranty Service

Warranty

JIT Cylinders, Inc. warrants every product of its manufacture to be of proper materials and first class workmanship. We agree to repair or replace, F.O.B. factory, but not to remove or install in the field, any perishable soft goods such as seals, which fail within a six-month period after shipment, normal wear accepted. We warrant for five years from date of shipment, all other parts which fail because of defective materials or workmanship. JIT assumes no responsibility for work done or expenses incurred, in the field, pertaining to such repairs or replacements, except upon written authority from our home office. Components not produced by JIT are subject only to the warranty extended to JIT by their respective manufacturer. When orders have been correctly filled, there shall be no returns without JIT's approval. Such returns will be subject to a restocking charge.

Return Goods Authorization (RGA)

All returns to JIT Cylinders must be accompanied with a Return Goods Authorization Number. A Return Goods Authorization Number may be obtained by contacting the plant. JIT Cylinders will inquire into why the return is being made and a number will be assigned at that time. Paperwork will be completed by JIT Cylinders giving details of the return from the information supplied by the customer or distributor. At the time the return is received the RGA number will be matched to the proper paperwork. This allows entry of the return without further questions or delays.

Quality Excellence Policy

We at JIT Cylinders are committed to serving the needs of our customers, as our name implies, Just-In-Time. We are committed to providing products and services which meet application requirements and are engineered for superior performance and reliability. We will achieve this through quality excellence in everything we do. Each task must be performed in conformance to requirements, and systems must be established which assure error-free performance in every area of manufacture. We understand that "quality excellence" depends on the personal performance of each employee. Because of this the entire management team and each member of manufacturing is dedicated and personally involved in the quality improvement process. We are dedicated to a policy of providing quality products and services that fully satisfy our customers' needs. We subscribe to the following quality absolutes:

Quality is defined as 100 percent conformance to requirements.

Our performance goal is to achieve error-free work in all functional areas.

Our system for causing quality is prevention.

We will track our progress in achieving total quality by measuring the price of non-conformance (waste).

Our primary objective will be continuous improvement.

100% Tested and Inspected!

Cylinders are first cycled at low pressure to remove air from the system and checked for proper mechanical action. During this procedure rod extension and stroke are measured. Test pressure is applied to cap and head ports in turn and under static pressure all joints are examined for leakage. Air lines are then fitted to cap and head in turn. The hydraulic fitting is removed from the non-pressurized port and a visual inspection made for air bubbles to indicate any piston seal leakage.

In addition, every cylinder is examined for:

Dimensional accuracy.

Proper unit switch actuation (if applicable).

Visual inspection for freedom of defects.

Proper assembly orientation.

Theoretical Forces Developed By Cylinders MH/ML Series

Output Forces at Specific Input Pressures

Bore	Rod Dia	Push Area	Pull Area	Forces in Pounds at Various Pressures (PSI)																			
				500 PSI		1000 PSI		1500 PSI		2000 PSI		3000 PSI		4000 PSI		5000 PSI							
				Push	Pull	Push	Pull	Push	Pull	Push	Pull	Push	Pull	Push	Pull	Push	Pull						
1.5	0.63	1.77	1.46	883	730	1,767	1,460	2,650	2,190	3,534	2,920	5,301	4,380	7,068	5,840	8,835	7,300						
	1.00		0.98															982	1,473	1,964	2,946	3,928	4,910
2	1.00	3.14	2.36	1,570	1,180	3,140	2,360	4,710	3,540	6,280	4,720	9,420	7,080	12,560	9,440	15,700	11,800						
	1.38		1.66															1,660	2,490	3,320	4,980	6,640	8,300
2.5	1.00	4.91	4.12	2,455	2,060	4,910	4,120	7,365	6,180	9,820	8,240	14,730	12,360	19,640	16,480	24,550	20,600						
	1.38		3.43															3,430	5,145	6,860	10,290	13,720	17,150
	1.75		2.51															2,510	3,765	5,020	7,530	10,040	12,550
3.25	1.38	8.30	6.82	4,150	3,410	8,300	6,820	12,450	10,230	16,600	13,640	24,900	20,460	33,200	27,280	41,500	34,100						
	1.75		5.90															5,900	8,850	11,800	17,700	23,600	29,500
	2.00		5.16															5,160	7,740	10,320	15,480	20,640	25,800
4	1.75	12.57	10.17	6,285	5,085	12,570	10,170	18,855	15,255	25,140	20,340	37,710	30,510	50,280	40,680	62,850	50,850						
	2.00		9.43															9,430	14,145	18,860	28,290	37,720	47,150
	2.50		7.66															7,660	11,490	15,320	22,980	30,640	38,300
5	2.00	19.64	16.50	9,820	8,250	19,640	16,500	28,460	24,750	39,280	33,000	58,920	49,500	78,560	66,000	98,200	82,500						
	2.50		14.73															14,730	22,095	29,460	44,190	58,920	73,650
	3.00		12.57															12,570	18,855	25,140	37,710	50,280	62,850
	3.50		10.02															10,020	15,030	20,040	30,060	40,080	50,100
6	2.50	28.27	23.36	14,135	11,680	28,270	23,360	42,405	35,040	56,540	46,720	84,810	70,080	113,080	93,440	141,350	116,800						
	3.00		21.20															21,200	31,800	42,400	63,600	84,800	106,000
	3.50		18.65															18,650	27,975	37,300	55,950	74,600	93,250
	4.00		15.70															15,700	23,550	31,400	47,100	62,800	78,500
7	3.00	38.49	31.42	19,245	15,710	38,490	31,420	57,735	47,130	76,980	62,840	115,470	94,260	153,960	125,680	192,450	157,100						
	3.50		28.87															28,870	43,305	57,740	86,610	115,480	144,350
	4.00		25.92															25,920	38,880	51,840	77,760	103,680	129,600
	4.50		22.59															22,590	33,885	45,180	67,770	90,360	112,950
	5.00		18.85															18,850	28,275	37,700	56,550	75,400	94,250
8	3.50	50.27	40.65	25,135	20,325	50,270	40,650	75,405	60,975	100,540	81,300	150,810	121,950	201,080	162,600	251,350	203,250						
	4.00		37.70															37,700	56,550	75,400	113,100	150,800	188,500
	4.50		34.37															34,370	51,555	68,740	103,110	137,480	171,850
	5.00		30.63															30,630	45,945	61,260	91,890	122,520	153,150
	5.50		26.51															26,510	39,765	53,020	79,530	106,040	132,550
10	4.50	78.54	62.64	39,270	31,320	78,540	62,640	117,810	93,960	157,080	125,280	235,620	187,920	314,160	250,560	392,700	313,200						
	5.00		58.90															58,900	88,350	117,800	176,700	235,600	294,500
	5.50		54.78															54,780	82,170	109,560	164,340	219,120	273,900
	7.00		40.05															40,050	60,075	80,100	120,150	160,200	200,250
12	5.50	113.1	89.34	56,550	44,670	113,100	89,340	169,650	134,010	226,200	178,680	339,300	268,020	452,400	357,360	565,500	446,700						
	7.00		74.61															74,610	111,915	149,220	223,830	298,440	373,050
	8.00		62.83															62,835	94,245	125,660	188,490	251,320	314,150
14	7.00	153.9	115.45	76,969	57,727	153,938	115,454	230,908	173,181	307,877	230,908	461,815	346,361	615,754	461,815	769,692	577,269						
	8.00		103.67															103,673	155,509	207,346	311,018	414,691	518,364
	10.00		75.40															75,398	113,098	150,797	226,195	301,594	376,992
16	8.00	201.1	150.80	100,531	75,398	201,062	150,797	301,594	226,195	402,125	301,594	603,187	452,390	804,250	603,187	1,005,312	753,984						
	10.00		122.52															122,522	183,784	245,045	367,567	490,090	612,612

Manufacturing Excellence

With over a century of manufacturing experience, consistent quality delivered on time is our guarantee. Being a 100% employee-owned company enhances the motivation of every JIT employee. Every employee understands their unique vital role toward earning and retaining long term customers.

JIT Cylinders is an employee owned company that does not make decisions based on stockholder value. We make decisions based on what our customer's value. Our goal is not to simply retain customers, we strive to continuously earn our customers by exceeding their expectations in terms of value, service, quality and delivery. Each day we compete for long term customers and are succeeding by nurturing a corporate culture that encourages and motivates our:

- *customer service managers to not answer phones, but service customers*
- *machinists to not 'cut chips', but deliver on-time*
- *engineers to not design, but innovate market driven*
- *sales managers to not sell, but offer economical best*

Our goal at JIT Cylinders is to achieve best-practice leadership in all processes. From our paperless manufacturing floor to our instant 24 hour support, we at JIT Cylinders are in business to serve customers and subscribe to the belief that our success will only follow the success of our customers.

Employee participation in quality-oriented teams also contribute to our quality manufacturing. Teams meet regularly to discuss better, faster, leaner and more economical ways to produce products and streamline manufacturing and sales operations. Our customers benefit from an improved product selection that is manufactured more efficiently.

Product quality is further enhanced by our continuing investment in capital equipment. Substantial expenditures have been made for flexible unmanned machining centers, computers on the manufacturing floor, CNC and NC machining centers, advanced material handling equipment, and testing stands.

The combination of dedicated, motivated and skilled employees coupled with state-of-the-art automated equipment and ample manufacturing capacity, results in a competitively priced, high-quality cylinder delivered on-time to customers worldwide.

Leadership in Innovation Unequaled Integrity of Design

In keeping pace with tomorrow, JIT Cylinders Research and Development Division believes that distinguishing itself through innovation is an essential factor for continued success. The objective of each project strives to exceed current and future application requirements.

Substantial investments are made to strengthen JIT Cylinders high-technology systems capabilities. Key initiatives are focused toward combining electronic controls, and new structural materials with environmental friendly mediums to improve productivity, energy savings, operator efficiency and comfort.

A commitment to quality engineering, research, and product development remains our principal focus.

"At JIT (Just-In-Time) Cylinders,

we supply

cylinder solutions for today and tomorrow's industrial applications. Being 100% employee owned

we work

as a unified team to exceed our customers' requirements. Through this motivational approach,

we deliver

innovative and responsive cylinder application solutions. At the same time,

we support

your engineering, design and manufacturing teams. Through this approach

we build

our leadership and strengthen our business to ensure

we create

long term partnerships."