



CYLINDERS

The responsive solution

A Series

A detailed 3D rendering of a high-pressure pneumatic cylinder, shown in a perspective view. The cylinder is metallic and features a long, threaded rod extending from one end. The background is a large, light grey circle on a white background.

High Pressure Pneumatic

2201 Highway 31 S
Hartselle, AL 35640

tel **256.751.2548**
fax: **256.751.2189**

www.jitcylinders.com

1.5" to 28"
22 Mounting Styles
Up to 250 PSI
Steel Construction

JIT Cylinders A Series Catalog

Table of Contents

Introduction	Page 1
Model Code	2
Cylinder Cross Section	3
Feature, Advantages, Benefits	4
Application Data	5
Cylinder Options	6
"A" Series Tie Rod Mounts	7-8
"A" Series Clevis Mounts	9-10
"A" Series Foot Mounts	11-12
"A" Series Front Flange Mounts	13-14
"A" Series Rear Flange Mounts	15-16
"A" Series Centerline Lug Mounts	17-18
"A" Series Optional Mounts	19-20
Standard Cylinder Accessories	21-24
Replacement Seal Kits	25
Warranty	26
Cylinder Interchangeability	27
Pressure Ratings and Output Forces	28
Manufacturing Excellence	29
Company Profile	30

Just In Time Stocking Levels

Our proactive inventory strategy with reactive responses help maintain product levels that keep your equipment productive with the fastest deliveries of stocked products. Our broad and responsive inventory system has been designed with the end user in mind, not outside shareholders.

Development of the A Series

Each JIT product has been designed by the industry specifically for industry. We don't tell you what you want, we have asked what you want. Product design input has been and still is actively collected from engineers, maintenance professionals and even operators to ensure maximum cylinder effectiveness. Through this on going effort, customers now have access to a product that has been designed:

"By You, For You"

Introduction to Excellence

Engineered products and applications expertise with the assurance that interchangeable parts are available worldwide and backed by expert service. JIT (Just-In-Time) Cylinders designs, manufactures and markets hydraulic, electro-hydraulic, pneumatic and electro-pneumatic components which provide force and motion control for industrial applications. Our components have superior adaptability allowing our engineers to present responsive solutions to maximize performance levels for all unique types of industrial equipment.

Tie Rod Principle

Tie rods are the most compact and versatile design for industrial cylinders. Tie rods are tightened to a high torque value to pre-load the cylinder allowing the body to expand (or breathe) under pressure without undermining performance capability. Welding is not required for standard assembly therefore there are no body distortion or fatigue concentrations.

Product Training

Training is provided to help ensure your systems are working at maximum efficiency via new technologies and best practices.

Performance you expect:

JIT Cylinders have been extensively designed to produce the following competitive advantages:

- * *Longer lifetime of service*
- * *Minimal downtime*
- * *Fast and easy installation*
- * *Simple and affordable repairs*
- * *No special tools required to make repairs.*
- * *Lower operating cost*
- * *More options available*
- * *Expedited deliveries with no extra charges (Why pay more for their inefficiencies?)*
- * *Dedicated service professionals on call*

Large Enough to Make a Difference; Small Enough to Know the Difference

We at JIT Cylinders supply solutions to problems rather than just product configurations. Each day we strive to improve our product performances by developing intelligent actuation capability.

MODEL CODE**A Series**

A	MP1	5"	14"	2"	1	BE	N	B	S
<i>1</i>	<i>2</i>	<i>3</i>	<i>4</i>	<i>5</i>	<i>6</i>	<i>7</i>	<i>8</i>	<i>9</i>	<i>10</i>

1 Model Series**A** High Pressure Pneumatic (Up to 250 psi)**2 Mounting Style (Pages 7-20)**

ME3	Full Head Flange	MS2	Side Lugs
ME4	Full Cap Flange	MS3	Centerline Lug
MF1	Rect Head Flange	MS4	Side Tapped
MF2	Rect Cap Flange	MS7	Foot Lug
MF5	Square Head Flange	MT1	Head Trunnion
MF6	Square Cap Flange	MT2	Cap Trunnion
MP1	Fixed Cap Clevis	MT4	Inter.Fixed Trunnion
MP2	Detachable Cap Clevis	MX0	No Mount
MP3	Pivot Eye	MX1	Extended Both Ends
MPU3	Self Aligning Eye	MX2	Extended Cap End
MS1	Angle Foot	MX3	Extended Head End

3 Bore Size (1.5" - 28")**4 Stroke (.001" - 360")****5 Rod Diameter (.625" - 12")****6 Rod Threads**

- 1 Small Male
- 2 Oversized Male
- 3 Standard Female
- 4 Safety Coupler
- 5 Special

7 Cushions

- NC Non Cushion
- RE Rod End
- CE Cap Ends
- BE Both Ends

8 Port Styles

- N NPT
- S SAE

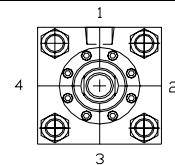
**9 Seals**

- B Nitrile
- P Polyurethane
- V Viton

10 Specials

- Air Bleeds
- Cast Iron Piston Rings
- Electroless Nickel Plated Cylinders
- Gland Drain
- Key Retainers
- Low Friction Seals
- Metallic Rod Scrapers
- Mixed Mounting Styles
- Non-Rotating Cylinders
- Proximity Switches
- Special, Rotated, or Oversize Ports
- Stainless Steel Construction
- Stop Tube (Indicate Total Gross)
- Tie Rod Extensions

We believe that a corporate strategy should be geared toward increasing the value of customers over the long term. Long-term increases to customer value are not possible without sufficient acceptance and input from the industrial population.

In following with our corporate strategy, each JIT product has been designed by the industry specifically for industry. We don't tell you what you want, we have asked what you want. Product design input has been and still is actively collected from engineers, maintenance professionals and even operators to ensure maximum cylinder effectiveness. Through this on going effort, customers now have access to a product that has been designed:

"By You, For You"

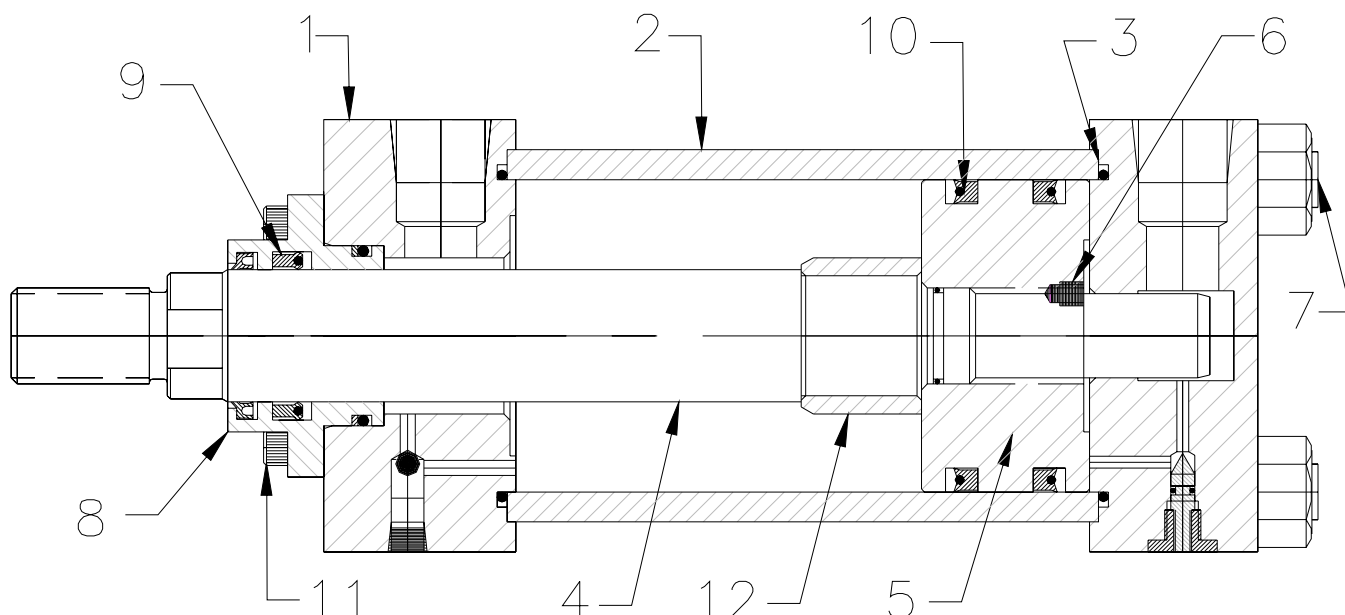

Cylinder Features

One Piece Bolt-On Rod Gland
Full Face Barrel Seal
Solid Cap Cushion Seal
Stepped Cushion Spears

Micro-Adjustable Captive Cushion Needle
100% of Piston Rods Assembled are Pinned
More Porting Configurations in Standard Head
Rod Stock more tolerable to side loads

Wider Piston reduces bearing loads
Tie Rods have rolled threads
Fastest Deliveries
Design Adaptability

Port Size Options

Ports that are smaller than standard can be supplied upon request at no extra charge. When ordering oversized ports, head component modifications may be necessary. If the port cannot be placed directly in the head, a "port boss" will be welded to the head surface. This will not insure that increased flow volume can enter the cylinder without restriction. Cylinders designed to have oversize ports with "full flow" capability may be ordered, but special construction of head and cap may alter basic envelope dimensions.

Superior Sealing Systems

Standard sealing systems have been designed to provide optimum performance across broad velocity and temperature ranges with a variety of fluids.

Advanced Cushioning System

Advanced cushioning system provides excellent acceleration and deceleration profiles that tolerate higher velocity, demanding applications and utilize a zero bypass leakage concept. The self-centering head cushion has been designed for closer tolerances, minimum wear, constant deceleration curve.

Feature, Advantages and Benefits

A Series

Component	Feature	Advantage	Benefit
1 End Caps	Head are machined from steel precision blocks to ensure concentricity of the cylinder.	Excellent strength and yield characteristics. Parallel and square surfaces.	Faster more efficient machining. Provides for accurate mountings and positive alignment.
2 Barrel	Damage-resistant heavy wall steel tubing honed to a micro finish bore.	DOM tube processing insures straighter and more concentric barrels. Tube I.D. is finished for low frictional drag and	Steel DOM tubing provides greater impact resistance for durability and long life.
3 Barrel Seal	Pilot fitted and torqued against the surface of a full diameter barrel.	Insures the effectiveness of the O-ring face seal with improved strength.	Provides leak free service with a full barrel diameter. Resists shearing of the o-ring for ID seals.
4 Rod	Piston rods are high yield strength, ground polished and chrome plated.	High yield material composition provides strength and flexibility. Chrome plating provides a smooth surface for effective sealing.	Strength for long life. Flexibility to prevent premature rod breakage.
5 Piston	One piece design machined from ductile iron. Has higher tensile strength, yield, and elongation than standard gray iron.	Wide bearing surface design reduces bearing loads while ensuring stability, concentricity, and parallelism to the barrel.	Piston stability, concentricity, and parallelism ensures smooth operation and consistent sealing for longer life.
6 Piston Rod Engagement	Piston is pilot fitted and secured to the rod by set screws staked in place with an o-ring seal under the piston	Pilot fitting ensures parallelism between the piston and the bore. The set screws with o-ring seal insure the piston to rod connection and prevents leakage under the piston.	Insures smooth operation. Prevents piston from backing off the rod. Prevents leakage at the rod to piston connection.
7 Tie Rods	100K minimum yield material with rolled threads.	Improved strength in threaded sections.	Rolled threads provide increased strength compared to cut threads.
8 Rod Gland	Unitized, threadless and one piece ductile gland is pilot fitted into a precision bored head to achieve concentricity. Longer than standard inboard bearing surface extends gland life. As specified by maintenance professionals, all glands include jacking screw holes for quick and safe removal.	One-Piece ductile iron rod gland provides 400% longer bearing life than conventional bronze glands. Protects against side loads and removes easily using a common Allen wrench. Longer inboard bearing surface provides for maximum bearing support and wear resistance	Ductile Iron ensures greater gland strength and long life. The one piece, removable gland ensures easy and quick change out for decreased down time.
9 Rod Seals	Mechanically energized, back beveled, rectangular rod seals. Rod wiper provides both wiping and sealing as secondary rod seal.	Provides consistent and even rod coverage, increased compression set resistance, maximum film-breaking ability, with rectangular shape that adds stability to prevent rolling.	The combination of rod seal and wiper provides virtually zero rod seal leakage.
10 Piston Seals	Mechanically energized, lip type polyurethane piston seals, are both tough and extrusion resistant.	Provides consistent and even contact with the bore, good compression set resistance, and stability to prevent rolling.	The combination of polyurethane piston seal and piston ID seal provides virtually zero piston seal leakage.
11 Fasteners	Grade 8 Tie Rod Nuts	Traceability when needed. Consistent quality, high strength.	Increased life, and higher fatigue factor.
12 Cushions	Adjustable floating stepped cushion spears design with solid cap cushion. Micro-Adjustment captured cushion needle with fine threads allows for safe and precise adjustments.	Less shock, quicker cushioning, improved durability. Tight tolerance for the solid cap seal eliminates the need for floating bushings. Fine threads and special tip design allow for precise adjustment over a broad range of operating conditions.	Assures smooth and responsive cushioning with a longer life. Ideal for fast stoking applications. Inner Hex head allows for safe cushion adjustment while under pressure.

Tie Rod Cylinder Solution

Our cylinder design is the compilation of best practice component concepts gathered from various departments within diverse industries. This cost-efficient design with the versatility to conform to any application criteria has been engineered to satisfy the requirements for optimum response, exceptional performance, and solid reliability. No one understands or meets the critical requirements of industry better than JIT Cylinders. By combining our extensive product and market knowledge with our unequalled technical expertise, we create products that ensure total customer satisfaction.

Non-Standard Modifications

Variations in Construction involving the use of non-standard dimensions, materials, or cylinder feature modifications are available upon request. Clearly describe any requirements that are not identifiable by the Model Code.

Ideal Mounting Applications

Lifting:

- MP1 Cap Clevis
- MF2 Cap Rectangular Flange
- MF6 Cap Square Flange
- ME6 Full Cap Flange
- MT2 Cap Trunnion
- MX2 Cap Extended Tie Rods

Pulling:

- ME3 Full Head Flange
- ME5 Head Flange
- MS2 Side Lug
- MS4 Side Tapped
- MF1 Head Rect Flange
- MP1 Cap Clevis
- MPU3 Spherical Eye
- MT4 Center Trunnion
- MT2 Cap Trunnion

Pushing:

- ME4 Full Cap Flange
- ME6 Cap Flange
- MS2 Side Lug
- MS4 Side Tapped
- MP1 Cap Clevis
- MPU3 Spherical Eye
- MF2 Cap Rectangular Flange
- MF6 Cap Square Flange
- MT4 Center Trunnion
- MT1 Head Trunnion

Pivot Motion:

- MP1 Cap Clevis
- MPU3 Spherical Eye
- MT4 Center Trunnion
- MT1 Head Trunnion

Advanced Cushioning System

Special floating stepped cushion spear with solid cap seal and micro-adjustable captured cushion needle help create less operating shocks, improved cushioning speeds, and improved durability with safe and precise adjustments. Tight tolerances for the solid cap seal eliminates the need for floating bushings. Special cushion needle tip design allows for precise adjustment over a broad range of operating conditions.

Cushion Lengths

Bore	Head	Cap
1.5	0.75	0.75
2.0	0.75	0.75
2.5	0.75	0.75
3.25	1.00	1.00
4.0	1.00	1.00
5.00	1.00	1.00
6.0	1.25	1.25
8.0	1.25	1.25



Standard Port Location

Standard port location (1) is at the top of the cylinder when looking into the rod end. Locations are 1, 2, 3, and 4 clockwise when looking at the cylinder rod end. NPT ports are standard for A series.

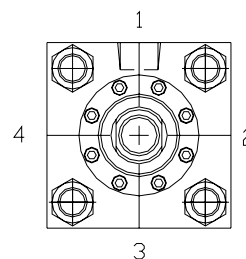

Standard Port Sizes

Bore	NPT Port	Max NPT Port	SAE Port	Max SAE Port
1.50	3/8	1/2	6	8
2.00	3/8	1/2	6	8
2.50	3/8	1/2	6	8
3.25	1/2	3/4	8	10
4.00	1/2	3/4	8	10
5.00	1/2	3/4	8	10
6.00	3/4	1	12	14
7.00	3/4	1	12	14
8.00	3/4	1	12	14

Tie Rod Torque

Bore	Ft. Lb.
1.5	10
2.0	20
2.5	20
3.3	30
4.0	30
5.0	65
6.0	65
7.0	115
8.0	115

Gland Drain

When not even a drop of external leakage can be tolerated, a gland drain option will provide the signal (predictive maintenance) that the rod seal has worn to the point of replacement preventing the danger of contamination from leakage. The gland drain redirects any accumulated fluid, between the rod seal and wiper, back to the tank. Air models may be modified in the same way to permit lubrication of rod seal and inner bearing surfaces.

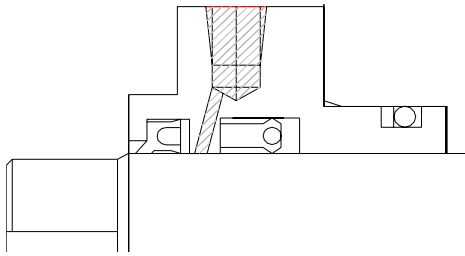

Stop Tube

Stop tubes reduce piston and bearing loads on long push stroking cylinders. A stop-tube increases the distance between the piston and rod bearing when the cylinder stroke is fully extended. This increased distance adds structural rigidity and helps prevent rod buckling. When ordering a cylinder with a stop-tube it is essential the stop-tube length, working stroke and total gross stroke be included.

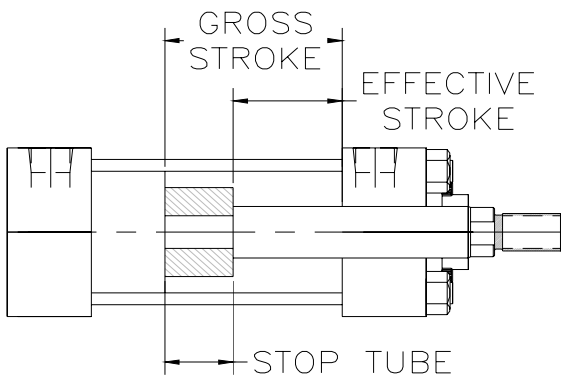

Adjustable Stroke

An integral stroke adjustment (externally adjusted) that is accomplished by the use of a bump rod threaded into the cylinder cap. Seals are incorporated to prevent external leakage, and a lock nut is included.

Stainless Steel Piston Rods

Many applications, especially those subjected to water spray, require the use of stainless steel piston rods. We furnish 17-4 pH hard chrome plated stainless steel, unless otherwise specified, which is considered a superior corrosion-resistant type of stainless steel. The minimum expected yield is 110,000 lb which should be considered with respect to operating pressure and column loading.

Proximity Switch

End of travel limit switches are available that signal rod position for control and safety circuits. The proximity switches for these cylinders are an inductive type switch with a sensing probe that "looks" at the cushion collar or spear providing full extension or full retraction indication.

Rod Boot

Rod-boots are used to protect the piston rod from harmful effects of severe operating environments. They are available for all cylinders. It is necessary to provide additional piston rod extension to allow space for the compressed rod boot length. The required extension varies with the rod diameter and stroke length.

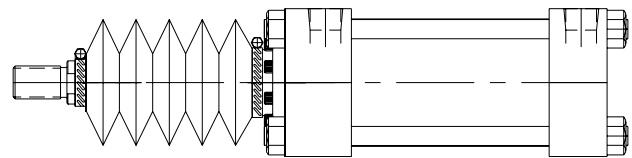

Air Bleed

Usually hydraulic cylinders will bleed themselves of air when ports are vertical, on top. Bleed ports are often desirable to remove entrapped air, for example, when the ports are on the bottom. High performance, high speed or heavy load applications are a few examples where air bleeds are also desirable.

**Tie Rods Extended Both End
MX1**

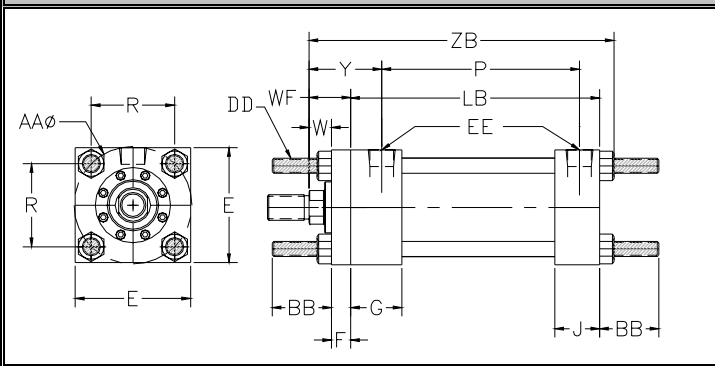

**Tie Rods Extended Cap End
MX2**

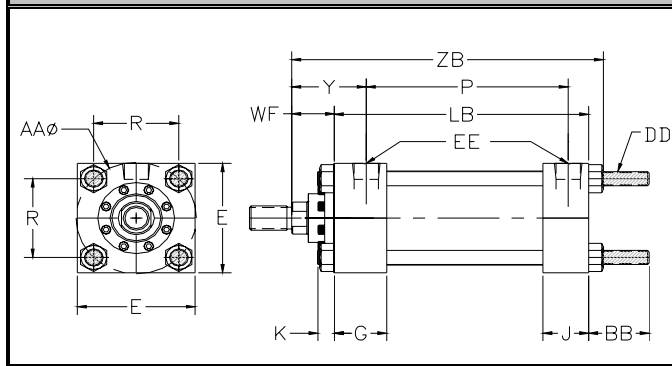

Centerline Mounting

The preferred cylinder installation method, centerline mounting places the mounting bolts in simple tension so that the mounting mechanism is protected from compound forces. Centerline mounting is a rigid mounting style and thus requires accurate cylinder alignment to prevent damage to cylinder working parts. Mounting configurations that provide centerline support are tie-rod mounts, flange mounts, rectangular head and cap cylinders, and centerline lug cylinders.

Recommended Applications

Tie Rod mounts are used for straight line force transfer. (MX3) Head extended tie rods for tension or pull, (MX2) Cap Extended Tie Rods for compression or push, and (MX1) Both Ends Extended Tie Rods for compression and tension.

The mounting surface should be flat and the frame sufficiently rigid to resist bending movements. Force on the rod should be perpendicular to the mounting surface and coincide with the centerline of the rod. For eccentric loads, oversized rods and stop tubes should be considered. Once fitted to the framework, the nuts provided should be correctly torqued.

**Tie Rods Extended Rod End
MX3**

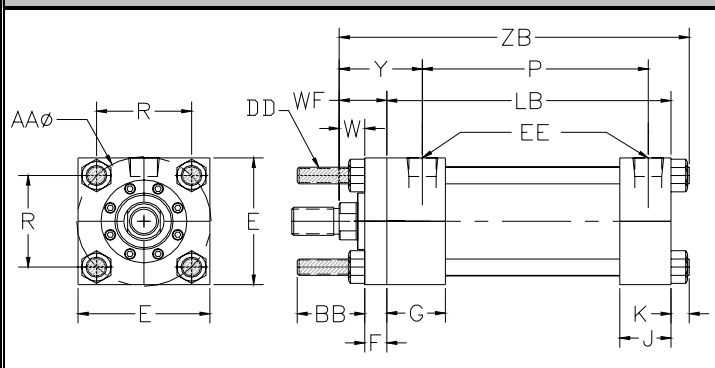

**Plain Mount
MX0**

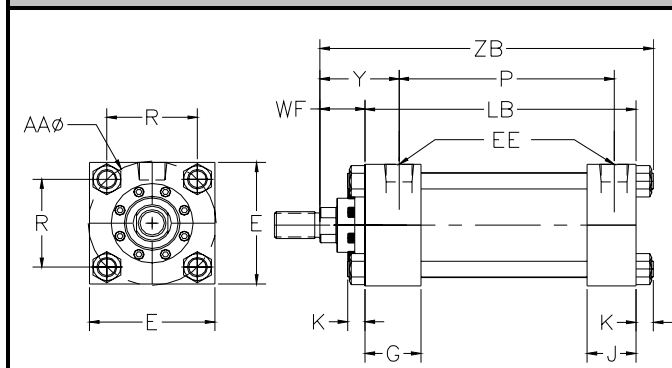

Tie Rod Mount Dimensions

BORE	E	EE-NPT	EE-SAE	F	G	J	K	AA	BB	DD	R	+ Stroke	
												LB	P
1.50	2.00	0.38	6	0.38	1.50	1.00	0.31	2.02	1.00	1/4-28	1.43	3.63	2.22
2.00	2.50	0.38	6	0.38	1.50	1.00	0.31	2.60	1.13	5/16-24	1.84	3.63	2.22
2.50	3.00	0.38	6	0.38	1.50	1.00	0.31	3.10	1.13	5/16-24	2.19	3.75	2.38
3.25	3.75	0.50	8	0.63	1.75	1.25	0.38	3.90	1.38	3/8-24	2.76	4.25	2.63
4.00	4.50	0.50	8	0.63	1.75	1.25	0.38	4.70	1.38	3/8-24	3.32	4.25	2.63
5.00	5.50	0.50	8	0.63	1.75	1.25	0.50	5.80	1.81	1/2-20	4.10	4.50	2.89
6.00	6.50	0.75	12	0.75	2.00	1.50	0.50	6.90	1.81	1/2-20	4.88	5.00	3.13
7.00	7.50	0.75	12		2.00	1.50	0.63	8.10	2.31	5/8-18	5.73	5.13	3.25
8.00	8.50	0.75	12		2.00	1.50	0.63	9.1	2.31	5/8-18	6.44	5.13	3.25

Style 1
Standard Male

The "KK" male thread ends provide a shoulder surface for mounting accessories. These rod ends are recommended for use when design permits.

Style 2
Oversized Male

The "CC" male thread ends provide a shoulder surface for mounting accessories. These rod ends are recommended for use when design permits.

Style 3
Standard Female

Female thread used with male accessories.

Style 4
Self Aligning Coupler

Used with Self-Aligning accessory for fast, close radial alignment.

Style 5
Special

Special rod ends made to suit customer requirements are available. Submit dimensional sketch or accurate description when desired.

VARIABLE ROD DIMENSIONS							+ Stroke
BORE	ROD DIA.	V	W	Y	WF	RP	ZB
1.50	0.63	0.25	0.63	1.97	1.00	2.00	4.94
	1.00	0.50	1.00	2.34	1.38	SQ.	5.31
2.00	0.63	0.25	0.63	1.97	1.00	2.00	4.94
	1.00	0.50	1.00	2.34	1.38	2.38	5.31
2.50	1.38	0.63	1.25	2.59	1.63	SQ.	5.56
	0.63	0.25	0.63	1.94	1.00	2.00	5.06
	1.00	0.50	1.00	2.31	1.38	2.38	5.44
3.25	1.38	0.63	1.25	2.56	1.63	2.94	5.69
	1.75	0.75	1.50	2.81	1.88	SQ.	5.94
	1.00	0.25	0.75	2.44	1.38	2.38	6.00
4.00	1.38	0.38	1.00	2.69	1.63	2.94	6.25
	1.75	0.50	1.25	2.94	1.88	3.38	6.50
	2.00	0.50	1.38	3.06	2.00	3.63	6.63
5.00	1.00	0.25	0.75	2.43	1.38	2.38	6.38
	1.38	0.38	1.00	2.68	1.63	2.94	6.63
	1.75	0.50	1.25	2.93	1.88	3.38	6.88
6.00	2.00	0.50	1.38	3.05	2.00	3.63	7.00
	1.38	0.25	0.88	2.81	1.63	2.94	7.13
	1.75	0.38	1.13	3.06	1.88	3.38	7.38
7.00	2.00	0.38	1.25	3.19	2.00	3.63	7.50
	2.50	0.50	1.50	3.44	2.25	4.19	7.75
	1.38	0.25	1.63	2.81	1.63	2.94	7.38
8.00	1.75	0.38	1.88	3.06	1.88	3.38	7.63
	2.00	0.38	2.00	3.19	2.00	3.63	7.75
	2.50	0.50	2.25	3.44	2.25	4.19	8.00

STANDARD ROD DIMENSIONS						
	0.63	1.00	1.38	1.75	2.00	2.50
A	0.75	1.13	1.63	2.00	2.25	3.00
B	1.12	1.50	2.00	2.37	2.62	3.12
C	0.38	0.50	0.63	0.75	0.88	1.00
D	0.50	0.88	1.13	1.50	1.69	2.06
KK	7/16-20	3/4-16	1-14	1 1/4-12	1 1/2-12	1 7/8-12
CC	1/2-20	7/8-14	1 1/4-12	1 1/2-12	1 3/4-12	2 1/4-12
AC	1.13	1.63	1.75	2.00	2.63	3.25
AD	0.63	0.94	1.06	1.31	1.69	1.94
AE	0.25	0.38	0.38	0.50	0.63	0.75
AF	0.38	0.69	0.88	1.13	1.38	1.75
AL	1.75	2.50	2.75	3.13	3.75	4.50

Important Note:

Style 1 Rod End is standard and will be supplied unless otherwise specified. Alternate styles 2, 3, and 4 are available at no extra charge. Additional "WF" and "A" can be supplied at an additional charge.

Four Full-Wrench-Flats

Cylinders can be produced with four full-wrench-flats for convenience during cylinder installation or replacement, as well as, a time and money saver. The flat is positioned for a good wrench hold using normal tools.

Spanner Wrench Holes

4" rod and larger have spanner wrench holes in place of wrench flats.

**REAR CLEVIS MOUNT
MP1**

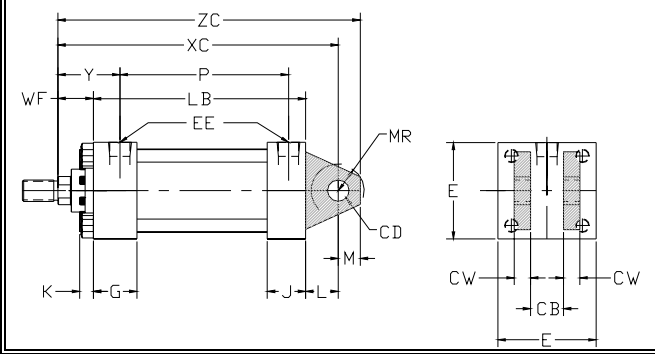

**REAR EYE MOUNT
MP3**

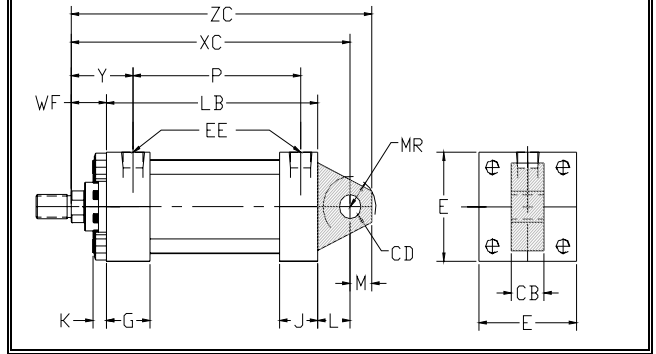

**DETACHABLE REAR CLEVIS MOUNT
MP2**

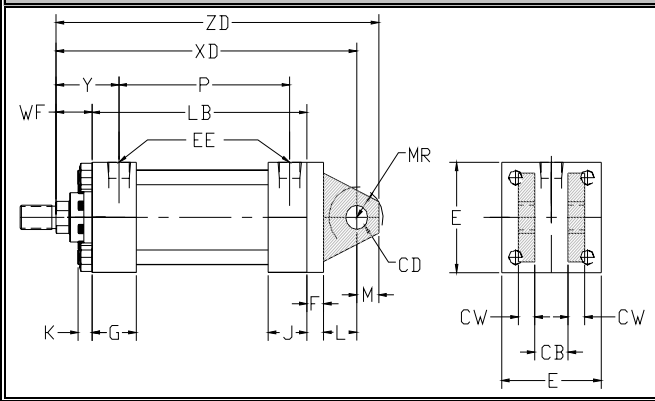

Recommended (Push and Pull Applications)

The centerline of the machine that attaches to the swivel pin must be perpendicular to the centerline of the piston rod and the curved path must be on one plane only. Any misalignment of the cylinder will cause excessive side loading on the gland and piston, which will lead to premature failure.



Clevis Mount Dimensions

BORE	E	EE-NPT	EE-SAE	G	J	K	L	M	CB	CD	CW	LR	MR	LB	P	+ Stroke
1.50	2.00	0.38	6	1.50	1.00	0.31	0.75	0.50	0.75	0.50	0.50	0.56	0.63	3.63	2.22	
2.00	2.50	0.38	6	1.50	1.00	0.31	0.75	0.50	0.75	0.50	0.50	0.56	0.63	3.63	2.22	
2.50	3.00	0.38	6	1.50	1.00	0.31	0.75	0.50	0.75	0.50	0.50	0.56	0.63	3.75	2.38	
3.25	3.75	0.50	8	1.75	1.25	0.38	1.25	0.75	1.25	0.75	0.63	1.00	0.94	4.25	2.63	
4.00	4.50	0.50	8	1.75	1.25	0.38	1.25	0.75	1.25	0.75	0.63	1.00	0.94	4.25	2.63	
5.00	5.50	0.50	8	1.75	1.25	0.50	1.25	0.75	1.25	0.75	0.63	1.00	0.94	4.50	2.89	
6.00	6.50	0.75	12	2.00	1.50	0.50	1.50	1.00	1.50	1.00	0.75	1.25	1.19	5.00	3.13	
7.00	7.50	0.75	12	2.00	1.50	0.63	1.50	1.00	1.50	1.00	0.75	1.25	1.19	5.13	3.25	
8.00	8.50	0.75	12	2.00	1.50	0.63	1.50	1.00	1.50	1.00	0.75	1.25	1.19	5.13	3.25	

**REAR SPHERICAL ROD EYE MOUNT
MPU3**

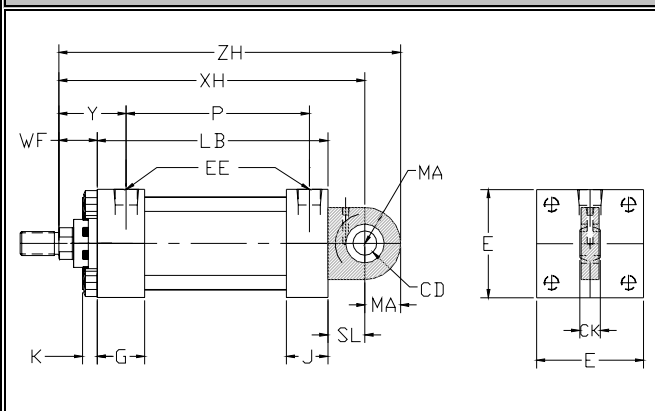

Recommended (Push and Pull Applications)

MPU3 mounts are for applications in which the stroke travels in a curved path in one plane where some misalignment is unavoidable. Care must be exercised to prevent rod buckling in compression applications with long strokes.

MPU3 Dimensions

BORE	SL	CK	MA
1.50	0.81	0.44	0.75
2.00	0.81	0.44	0.75
2.50	0.81	0.44	0.75
3.25	1.19	0.66	1.25
4.00	1.19	0.66	1.25
5.00	1.19	0.66	1.25
6.00	1.56	0.88	1.50

CONSULT FACTORY FOR LARGER BORE SIZES OR CUSTOM APPLICATIONS

Style 1
Standard Male

The "KK" male thread ends provide a shoulder surface for mounting accessories. These rod ends are recommended for use when design permits.

Style 2
Oversized Male

The "CC" male thread ends provide a shoulder surface for mounting accessories. These rod ends are recommended for use when design permits.

Style 3
Standard Female

Female thread used with male accessories.

Style 4
Self Aligning Coupler

Used with Self-Aligning accessory for fast, close radial alignment.

Style 5
Special

Special rod ends made to suit customer requirements are available. Submit dimensional sketch or accurate description when desired.

VARIABLE ROD DIMENSIONS							+ Stroke				
BORE	Rod Dia.	V	Y	XH	WF	RP	XC	XD	ZC	ZD	ZH
1.50	0.63	0.25	1.97	5.44	1.00	2.00	5.38	5.75	5.88	6.25	6.19
	1.00	0.50	2.34	5.81	1.38	SQ.	5.75	6.13	6.25	6.63	6.56
2.00	0.63	0.25	1.97	5.44	1.00	2.00	5.38	5.75	5.88	6.25	6.19
	1.00	0.50	2.34	5.81	1.38	2.38	5.75	6.13	6.25	6.63	6.56
2.50	1.38	0.63	2.59	5.25	1.63	SQ.	6.00	6.38	6.50	6.88	6.00
	0.63	0.25	1.94	5.56	1.00	2.00	5.50	5.88	6.00	6.38	6.31
	1.00	0.50	2.31	5.94	1.38	2.38	5.88	6.25	6.38	6.75	6.69
3.25	1.38	0.63	2.56	6.19	1.63	2.94	6.13	6.50	6.63	7.00	6.94
	1.75	0.75	2.81	6.44	1.88	SQ.	6.38	6.75	6.88	7.25	7.19
	1.00	0.25	2.44	6.81	1.38	2.38	6.88	7.50	7.63	8.25	8.06
4.00	1.38	0.38	2.69	7.06	1.63	2.94	7.13	7.75	7.88	8.50	8.31
	1.75	0.50	2.94	7.31	1.88	3.38	7.38	8.00	8.13	8.75	8.56
	2.00	0.50	3.06	7.44	2.00	3.63	7.50	8.13	8.25	8.88	8.69
5.00	1.00	0.25	2.44	6.81	1.38	2.38	6.88	7.50	7.63	8.25	8.06
	1.38	0.38	2.69	7.06	1.63	2.94	7.13	7.75	7.88	8.50	8.31
	1.75	0.50	2.94	7.31	1.88	3.38	7.38	8.00	8.13	8.75	8.56
6.00	2.00	0.50	3.06	7.44	2.00	3.63	7.50	8.13	8.25	8.88	8.69
	1.00	0.25	2.43	7.06	1.38	2.38	7.13	7.75	7.88	8.50	8.31
	1.38	0.38	2.68	7.31	1.63	2.94	7.38	8.00	8.13	8.75	8.56
7.00	1.75	0.50	2.93	7.56	1.88	3.38	7.63	8.25	8.38	9.00	8.81
	2.00	0.50	3.05	7.69	2.00	3.63	7.75	8.38	8.50	9.13	8.94
	1.38	0.25	2.81	8.19	1.63	2.94	8.13	8.88	9.13	9.88	9.44
8.00	1.75	0.38	3.06	8.44	1.88	3.38	8.38	9.13	9.38	10.13	9.69
	2.00	0.38	3.19	8.56	2.00	3.63	8.50	9.25	9.50	10.25	9.81
	2.50	0.50	3.44	8.81	2.25	4.19	8.75	9.50	9.75	10.50	10.06
9.00	1.38	0.25	2.81		1.63	2.94	8.25	8.25	9.25	9.25	
	1.75	0.38	3.06		1.88	3.38	8.50	8.50	9.50	9.50	
	2.00	0.38	3.19		2.00	3.63	8.63	8.63	9.63	9.63	
10.00	2.50	0.50	3.44		2.25	4.19	8.88	8.88	9.88	9.88	
	1.38	0.25	2.81		1.63	2.94	8.25	8.25	9.25	9.25	
	1.75	0.38	3.06		1.88	3.38	8.50	8.50	9.50	9.50	
11.00	2.00	0.38	3.19		2.00	3.63	8.63	8.63	9.63	9.63	
	2.50	0.50	3.44		2.25	4.19	8.88	8.88	9.88	9.88	
	1.38	0.25	2.81		1.63	2.94	8.25	8.25	9.25	9.25	
12.00	1.75	0.38	3.06		1.88	3.38	8.50	8.50	9.50	9.50	
	2.00	0.38	3.19		2.00	3.63	8.63	8.63	9.63	9.63	
	2.50	0.50	3.44		2.25	4.19	8.88	8.88	9.88	9.88	

STANDARD ROD DIMENSIONS						
	0.63	1.00	1.38	1.75	2.00	2.50
A	0.75	1.13	1.63	2.00	2.25	3.00
B	1.12	1.50	2.00	2.37	2.62	3.12
C	0.38	0.50	0.63	0.75	0.88	1.00
D	0.50	0.88	1.13	1.50	1.69	2.06
KK	7/16-20	3/4-16	1-14	1 1/4-12	1 1/2-12	1 7/8-12
CC	1/2-20	7/8-14	1 1/4-12	1 1/2-12	1 3/4-12	2 1/4-12
AC	1.13	1.63	1.75	2.00	2.63	3.25
AD	0.63	0.94	1.06	1.31	1.69	1.94
AE	0.25	0.38	0.38	0.50	0.63	0.75
AF	0.38	0.69	0.88	1.13	1.38	1.75
AL	1.75	2.50	2.75	3.13	3.75	4.50

Important Note:

Style 1 Rod End is standard and will be supplied unless otherwise specified. Alternate styles 2, 3, and 4 are available at no extra charge. Additional "WF" and "A" can be supplied at an additional charge.

Four Full-Wrench-Flats

Cylinders can be produced with four full-wrench-flats for convenience during cylinder installation or replacement, as well as, a time and money saver. The flat is positioned for a good wrench hold using normal tools.

Spanner Wrench Holes

4" rod and larger have spanner wrench holes in place of wrench flats.

A Foot Mounted cylinder secures the cylinder along its side. Since the mounting surface plane is not centered directly on the line of force, the mounting bolts are subjected to a significant amount of shear stress. With excessive loads, a cylinder should be 'keyed' to absorb shear stress loads allowing mounting bolts to remain in simple tension. Because foot mounts are rigid, they require accurate cylinder alignment.

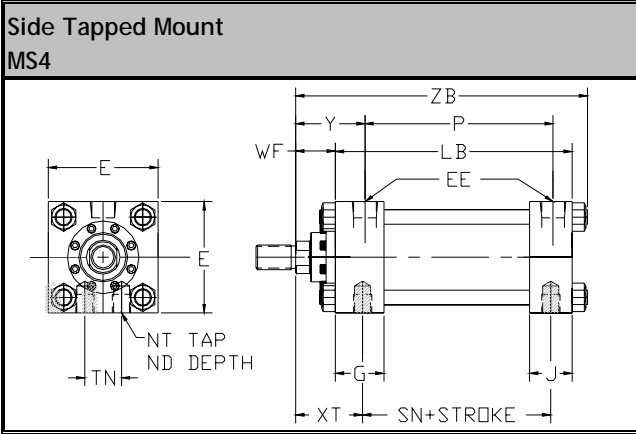
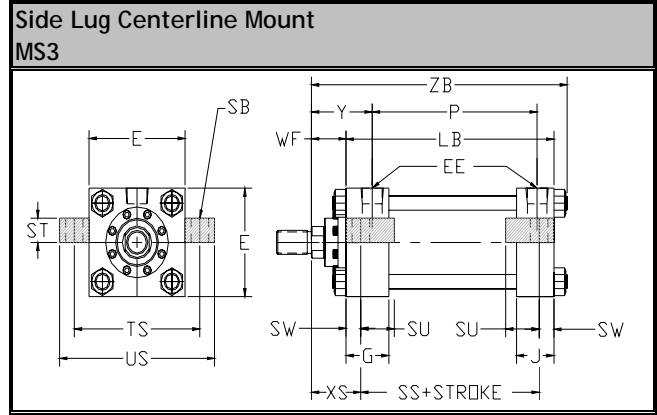
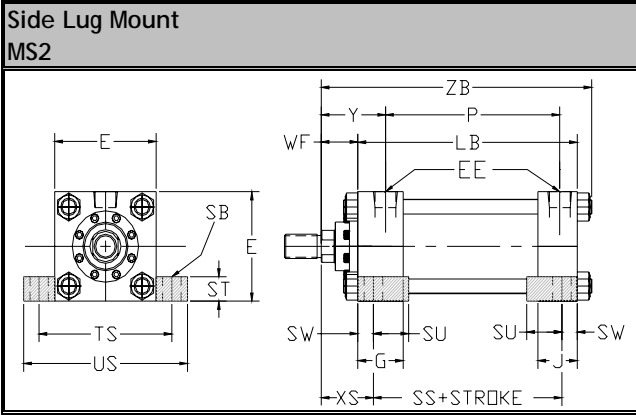

Recommended Applications

These mounts are for moving loads along a flat guided surface. The load should be guided to traverse along the centerline of the piston rod. With unsupported loads, the gland will absorb excessive force, therefore an oversized rod and stop tube should be considered. The mounting surface should be flat and parallel to the centerline of the piston rod. The frame on which the cylinder is mounted must be sufficiently rigid to resist bending movements. When mounting the cylinder, high tensile socket head cap screws or hex head bolts should be used, tighten to the manufacture's recommended torque.

Foot Mount Dimensions

BORE	E	EE-NPT	EE-SAE	G	SN	J	ND	NT	SB	SS	ST	SU	SW	TS	TN	US
1.50	2.00	0.38	6	1.50	2.25	1.00	0.25	1/4-20	0.44	2.88	0.50	0.94	0.38	2.75	0.63	3.50
2.00	2.50	0.38	6	1.50	2.25	1.00	0.31	5/16-18	0.44	2.88	0.50	0.94	0.38	3.25	0.88	4.00
2.50	3.00	0.38	6	1.50	2.38	1.00	0.38	3/8-16	0.44	3.00	0.50	0.94	0.38	3.75	1.25	4.50
3.25	3.75	0.50	8	1.75	2.63	1.25	0.50	1/2-13	0.56	3.25	0.75	1.25	0.50	4.75	1.50	5.75
4.00	4.50	0.50	8	1.75	2.63	1.25	0.50	1/2-13	0.56	3.25	0.75	1.25	0.50	5.50	2.06	6.50
5.00	5.50	0.50	8	1.75	2.88	1.25	0.63	5/8-11	0.81	3.13	1.00	1.56	0.69	6.88	2.69	8.25
6.00	6.50	0.75	12	2.00	3.13	1.50	0.75	3/4-10	0.81	3.63	1.00	1.56	0.69	7.88	3.25	9.25
7.00	7.50	0.75	12	2.00	3.25	1.50	0.75	3/4-10	0.81	3.75	1.00	1.56	0.69	8.88	3.75	10.25
8.00	8.50	0.75	12	2.00	3.25	1.50	0.75	3/4-10	0.81	3.75	1	1.56	0.69	9.88	4.50	11.25

**Extended Keyplate for MS2 and MS4 Mounts
Recommended Keyplate Usage**

All side mounted cylinders can be supplied with thrust keys. Extending a gland retainer provides a key which fits into a milled slot in the mounting surface assures that the cylinder will not shift in severe service. For high shock applications a keyed side lug mount or keyed tapped mount should always be considered. The keyplate is suitable only for shear loads and only one end should be keyed.

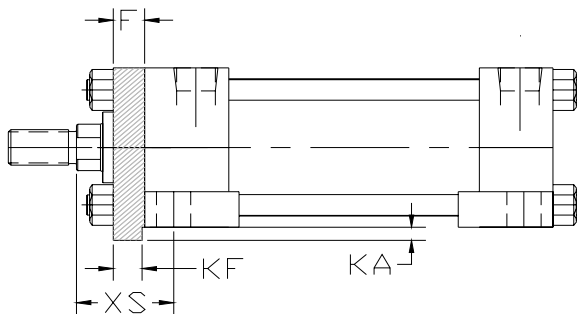

Bore	Add Stroke		KeyPlate		
	P	LB	KA	F	KF
1.50	2.22	3.63	0.19	0.38	0.31
2.00	2.22	3.63	0.19	0.38	0.31
2.50	2.38	3.75	0.19	0.38	0.31
3.25	2.63	4.25	0.31	0.63	0.56
4.00	2.63	4.25	0.31	0.63	0.56
5.00	2.89	4.50	0.31	0.63	0.56
6.00	3.13	5.00	0.38	0.75	0.69
7.00	3.25	5.13			
8.00	3.25	5.13			

Style 1
Standard Male

The "KK" male thread ends provide a shoulder surface for mounting accessories. These rod ends are recommended for use when design permits.

Style 2
Oversized Male

The "CC" male thread ends provide a shoulder surface for mounting accessories. These rod ends are recommended for use when design permits.

Style 3
Standard Female

Female thread used with male accessories.

Style 4
Self Aligning Coupler

Used with Self-Aligning accessory for fast, close radial alignment.

Style 5
Special

Special rod ends made to suit customer requirements are available. Submit dimensional sketch or accurate description when desired.

VARIABLE ROD DIMENSIONS										+ Stroke
Bore	Rod Dia	V	W	Y	WF	RP	XS	XT	ZB	
1.50	0.63	0.25	0.63	1.97	1.00	2.00	1.38	1.94	4.94	
	1.00	0.50	1.00	2.34	1.38	SQ.	1.75	2.31	5.31	
2.00	0.63	0.25	0.63	1.97	1.00	2.00	1.38	1.94	4.94	
	1.00	0.50	1.00	2.34	1.38	2.38	1.75	2.31	5.31	
2.50	1.38	0.63	1.25	2.59	1.63	SQ.	2.00	2.56	5.56	
	0.63	0.25	0.63	1.94	1.00	2.00	1.38	1.94	5.06	
	1.00	0.50	1.00	2.31	1.38	2.38	1.75	2.31	5.44	
3.25	1.38	0.63	1.25	2.56	1.63	2.94	2.00	2.56	5.69	
	1.75	0.75	1.50	2.81	1.88	SQ.	2.25	2.81	5.94	
	1.00	0.25	0.75	2.44	1.38	2.38	1.88	2.44	6.00	
	1.38	0.38	1.00	2.69	1.63	2.94	2.13	2.69	6.25	
4.00	1.75	0.50	1.25	2.94	1.88	3.38	2.38	2.94	6.50	
	2.00	0.50	1.38	3.06	2.00	3.63	2.50	3.06	6.63	
	1.00	0.25	0.75	2.43	1.38	2.38	2.06	2.44	6.38	
5.00	1.38	0.38	1.00	2.68	1.63	2.94	2.31	2.69	6.63	
	1.75	0.50	1.25	2.93	1.88	3.38	2.56	2.94	6.88	
	2.00	0.50	1.38	3.05	2.00	3.63	2.69	3.06	7.00	
6.00	1.38	0.25	0.88	2.81	1.63	2.94	2.31	2.81	7.13	
	1.75	0.38	1.13	3.06	1.88	3.38	2.56	3.06	7.38	
	2.00	0.38	1.25	3.19	2.00	3.63	2.69	3.19	7.50	
	2.50	0.50	1.50	3.44	2.25	4.19	2.94	3.44	7.75	
7.00	1.38	0.25	1.63	2.81	1.63	2.94	2.31	2.81	7.38	
	1.75	0.38	1.88	3.06	1.88	3.38	2.56	3.06	7.63	
	2.00	0.38	2.00	3.19	2.00	3.63	2.69	3.19	7.75	
8.00	2.50	0.50	2.25	3.44	2.25	4.19	2.94	3.44	8.00	
	1.38	0.25	1.63	2.81	1.63	2.94	2.31	2.81	7.38	
	1.75	0.38	1.88	3.06	1.88	3.38	2.56	3.06	7.63	
	2.00	0.38	2.00	3.19	2.00	3.63	2.69	3.19	7.75	
8.00	2.50	0.50	2.25	3.44	2.25	4.19	2.94	3.44	8.00	

STANDARD ROD DIMENSIONS						
	0.63	1.00	1.38	1.75	2.00	2.50
A	0.75	1.13	1.63	2.00	2.25	3.00
B	1.12	1.50	2.00	2.37	2.62	3.12
C	0.38	0.50	0.63	0.75	0.88	1.00
D	0.50	0.88	1.13	1.50	1.69	2.06
KK	7/16-20	3/4-16	1-14	1 1/4-12	1 1/2-12	1 7/8-12
CC	1/2-20	7/8-14	1 1/4-12	1 1/2-12	1 3/4-12	2 1/4-12
AC	1.13	1.63	1.75	2.00	2.63	3.25
AD	0.63	0.94	1.06	1.31	1.69	1.94
AE	0.25	0.38	0.38	0.50	0.63	0.75
AF	0.38	0.69	0.88	1.13	1.38	1.75
AL	1.75	2.50	2.75	3.13	3.75	4.50

Important Note:

Style 1 Rod End is standard and will be supplied unless otherwise specified. Alternate styles 2, 3, and 4 are available at no extra charge. Additional "WF" and "A" can be supplied at an additional charge.

Four Full-Wrench-Flats

Cylinders can be produced with four full-wrench-flats for convenience during cylinder installation or replacement, as well as, a time and money saver. The flat is positioned for a good wrench hold using normal tools.

Spanner Wrench Holes

4" rod and larger have spanner wrench holes in place of wrench flats.

FRONT RECTANGULAR FLANGE MOUNT

MF1

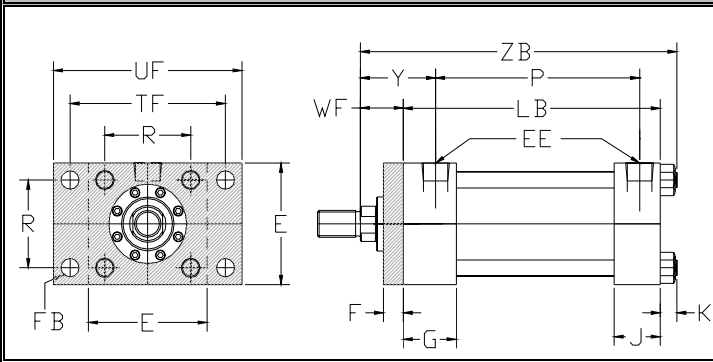

Recommended Usage

Front flange mounts are designed for straight line force transfer in which the cylinder is used in tension (pull). For pull applications mounting is always recommended on the front of the flange to resist bending moments. For heavy duty applications, the Front Head Flange Mount (ME5) should be considered. MF1 and MF5 mount will not function properly at full operating pressures; consult factory for application guidelines.

Recommended Mounting Practice

The frame on which the cylinder is mounted must be flat and sufficiently rigid to resist bending movements. High tensile socket head cap screws or hex head bolts should be used to mount the cylinder and tighten to the recommended torque value.

FRONT SQUARE FLANGE MOUNT

MF5

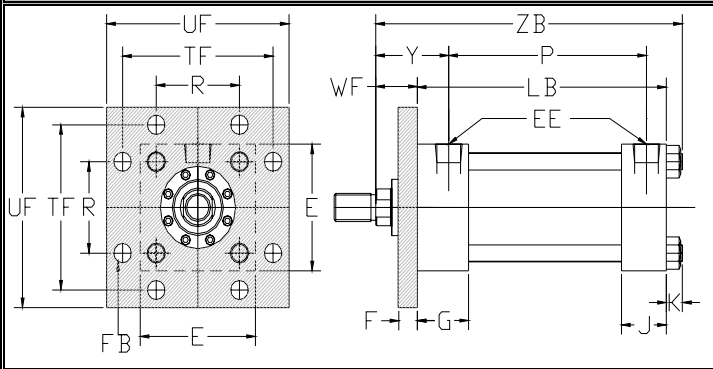

Good Solution

Front Rectangular Flange Mount

While this mount is a widely used one, its use should be restricted to pressures under 1000psi, short strokes (under 36") and standard rod diameters. Note that the Front Head Flange mount has the same mounting hole pattern.

Better Solution

Front Square Flange Mount

Satisfactory for maximum operating pressure and long strokes if properly applied.

FRONT HEAD FLANGE MOUNT

ME3

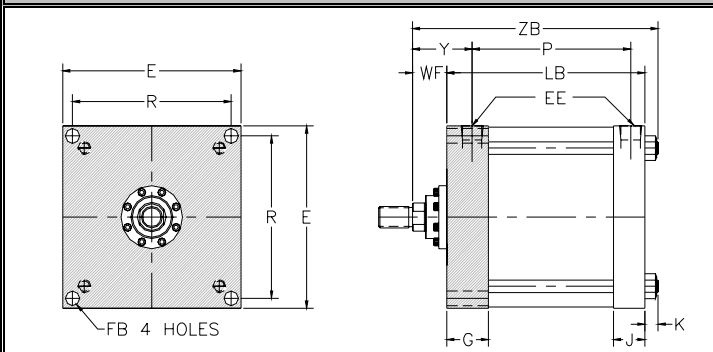

Best Solution

Front Head Flange Mount

Highly recommended flange mounting. With this style, the cylinder can be mounted on the back face of the flange desired. This mount is used extensively on high tonnage presses and other heavy duty applications. We highly recommend that consideration be given to the use of a Style 5 rod end and Self-Aligning Coupler to achieve correct radial alignment.

Front Flange Mount Dimensions

BORE	E	EE-NPT	EE-SAE	F	FB	G	J	K	R	TF	UF	+ Stroke	
												LB	P
1.50	2.00	0.38	6	0.38	0.56	1.50	1.00	0.31	1.43	2.75	3.38	3.63	2.22
2.00	2.50	0.38	6	0.38	0.38	1.50	1.00	0.31	1.84	3.38	4.13	3.63	2.22
2.50	3.00	0.38	6	0.38	0.38	1.50	1.00	0.31	2.19	3.88	4.63	3.75	2.38
3.25	3.75	0.50	8	0.63	0.44	1.75	1.25	0.38	2.76	4.69	5.50	4.25	2.63
4.00	4.50	0.50	8	0.63	0.44	1.75	1.25	0.38	3.32	5.44	6.25	4.25	2.63
5.00	5.50	0.50	8	0.63	0.56	1.75	1.25	0.50	4.10	6.63	7.63	4.50	2.89
6.00	6.50	0.75	12	0.75	0.56	2.00	1.50	0.50	4.88	7.63	8.63	5.00	3.13
7.00	7.50	0.75	12		0.56	2.00	1.50	0.63	6.75			5.13	3.25
8.00	8.50	0.75	12		0.69	2.00	1.50	0.63	7.57			5.13	3.25

Style 1
Standard Male

The "KK" male thread ends provide a shoulder surface for mounting accessories. These rod ends are recommended for use when design permits.

Style 2
Oversized Male

The "CC" male thread ends provide a shoulder surface for mounting accessories. These rod ends are recommended for use when design permits.

Style 3
Standard Female

Female thread used with male accessories.

Style 4
Self Aligning Coupler

Used with Self-Aligning accessory for fast, close radial alignment.

Style 5
Special

Special rod ends made to suit customer requirements are available. Submit dimensional sketch or accurate description when desired.

VARIABLE ROD DIMENSIONS							+ Stroke
BORE	ROD DIA.	V	W	Y	WF	RP	ZB
1.50	0.63	0.25	0.63	1.97	1.00	2.00	4.94
	1.00	0.50	1.00	2.34	1.38	SQ.	5.31
2.00	0.63	0.25	0.63	1.97	1.00	2.00	4.94
	1.00	0.50	1.00	2.34	1.38	2.38	5.31
	1.38	0.63	1.25	2.59	1.63	SQ.	5.56
2.50	0.63	0.25	0.63	1.94	1.00	2.00	5.06
	1.00	0.50	1.00	2.31	1.38	2.38	5.44
	1.38	0.63	1.25	2.56	1.63	2.94	5.69
	1.75	0.75	1.50	2.81	1.88	SQ.	5.94
3.25	1.00	0.25	0.75	2.44	1.38	2.38	6.00
	1.38	0.38	1.00	2.69	1.63	2.94	6.25
	1.75	0.50	1.25	2.94	1.88	3.38	6.50
4.00	2.00	0.50	1.38	3.06	2.00	3.63	6.63
	1.00	0.25	0.75	2.44	1.38	2.38	6.00
	1.38	0.38	1.00	2.69	1.63	2.94	6.25
	1.75	0.50	1.25	2.94	1.88	3.38	6.50
5.00	2.00	0.50	1.38	3.06	2.00	3.63	6.63
	1.00	0.25	0.75	2.43	1.38	2.38	6.38
	1.38	0.38	1.00	2.68	1.63	2.94	6.63
	1.75	0.50	1.25	2.93	1.88	3.38	6.88
6.00	2.00	0.50	1.38	3.05	2.00	3.63	7.00
	1.38	0.25	0.88	2.81	1.63	2.94	7.13
	1.75	0.38	1.13	3.06	1.88	3.38	7.38
7.00	2.00	0.38	1.25	3.19	2.00	3.63	7.50
	2.50	0.50	1.50	3.44	2.25	4.19	7.75
	1.38	0.25	1.63	2.81	1.63	2.94	7.38
	1.75	0.38	1.88	3.06	1.88	3.38	7.63
8.00	2.00	0.38	2.00	3.19	2.00	3.63	7.75
	2.50	0.50	2.25	3.44	2.25	4.19	8.00
	1.38	0.25	1.63	2.81	1.63	2.94	7.38
	1.75	0.38	1.88	3.06	1.88	3.38	7.63

STANDARD ROD DIMENSIONS						
	0.63	1.00	1.38	1.75	2.00	2.50
A	0.75	1.13	1.63	2.00	2.25	3.00
B	1.12	1.50	2.00	2.37	2.62	3.12
C	0.38	0.50	0.63	0.75	0.88	1.00
D	0.50	0.88	1.13	1.50	1.69	2.06
KK	7/16-20	3/4-16	1-14	1 1/4-12	1 1/2-12	1 7/8-12
CC	1/2-20	7/8-14	1 1/4-12	1 1/2-12	1 3/4-12	2 1/4-12
AC	1.13	1.63	1.75	2.00	2.63	3.25
AD	0.63	0.94	1.06	1.31	1.69	1.94
AE	0.25	0.38	0.38	0.50	0.63	0.75
AF	0.38	0.69	0.88	1.13	1.38	1.75
AL	1.75	2.50	2.75	3.13	3.75	4.50

Important Note:

Style 1 Rod End is standard and will be supplied unless otherwise specified. Alternate styles 2, 3, and 4 are available at no extra charge. Additional "WF" and "A" can be supplied at an additional charge.

Four Full-Wrench-Flats

Cylinders can be produced with four full-wrench-flats for convenience during cylinder installation or replacement, as well as, a time and money saver. The flat is positioned for a good wrench hold using normal tools.

Spanner Wrench Holes

4" rod and larger have spanner wrench holes in place of wrench flats.

REAR RECTANGULAR FLANGE MOUNT

MF2

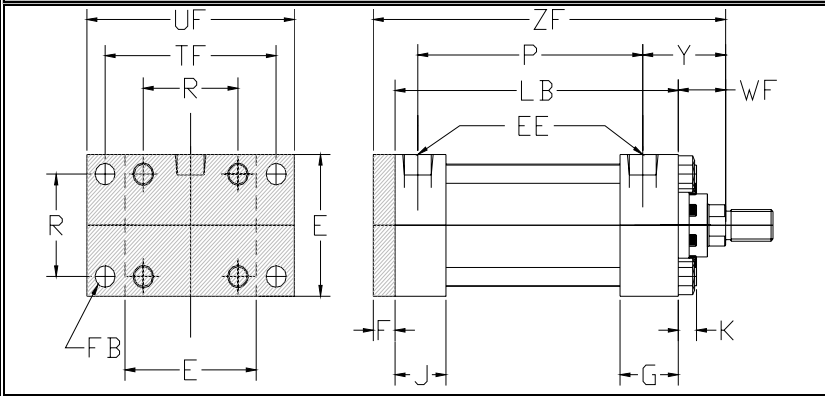

REAR SQUARE FLANGE MOUNT

MF6

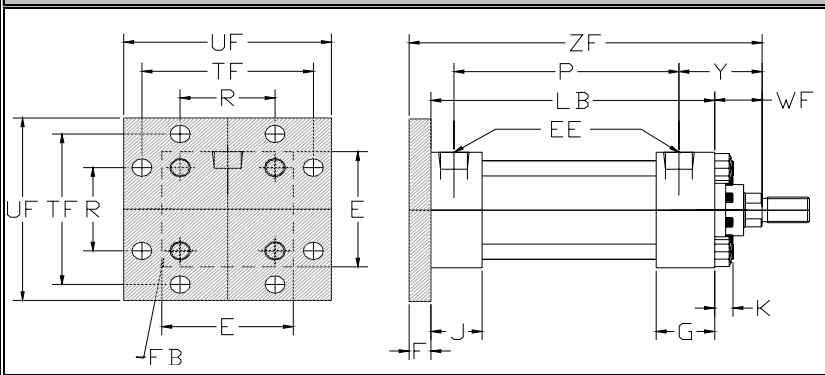

REAR HEAD FLANGE MOUNT

ME4

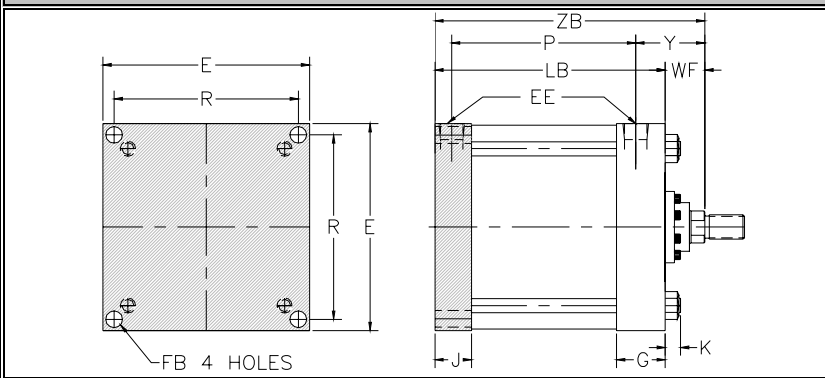

Recommended Usage

Rear flange mounts are designed for straight line force transfer in which the cylinder is used in compression (push). For push applications mounting is always recommended on the back of the flange to resist bending moments. For heavy duty applications, the Rear Head Flange Mount (ME6) should be considered. MF2 and MF6 mount will not function properly at full operating pressures; consult factory for application guidelines.

Recommended Mounting Practice

The frame on which the cylinder is mounted must be flat and sufficiently rigid to resist bending movements. High tensile socket head cap screws or hex head bolts should be used to mount the cylinder and tighten to the recommended torque value.

Good Solution

Rear Rectangular Flange Mount

While this mount is a widely used one, its use should be restricted to pressures under 1000 psi, short strokes (under 36") and standard rod diameters. Note that the Rear Head Flange mount has the same mounting hole pattern.

Better Solution

Rear Square Flange Mount

Satisfactory for maximum operating pressure and long strokes if properly applied.

Best Solution

Rear Head Flange Mount

Highly recommended flange mounting that can be mounted on the back face. This mount is used extensively on high tonnage presses and other heavy duty applications. We recommend that consideration be given to the use of a Self-Aligning Coupler to achieve correct radial alignment.

Rear Flange Mount Dimensions

BORE	E	EE-NPT	EE-SAE	F	FB	G	J	K	R	TF	UF	+ Stroke	
												LB	P
1.50	2.00	0.38	6	0.38	0.56	1.50	1.00	0.31	1.43	2.75	3.38	3.63	2.22
2.00	2.50	0.38	6	0.38	0.38	1.50	1.00	0.31	1.84	3.38	4.13	3.63	2.22
2.50	3.00	0.38	6	0.38	0.38	1.50	1.00	0.31	2.19	3.88	4.63	3.75	2.38
3.25	3.75	0.50	8	0.63	0.44	1.75	1.25	0.38	2.76	4.69	5.50	4.25	2.63
4.00	4.50	0.50	8	0.63	0.44	1.75	1.25	0.38	3.32	5.44	6.25	4.25	2.63
5.00	5.50	0.50	8	0.63	0.56	1.75	1.25	0.50	4.10	6.63	7.63	4.50	2.89
6.00	6.50	0.75	12	0.75	0.56	2.00	1.50	0.50	4.88	7.63	8.63	5.00	3.13
7.00	7.50	0.75	12		0.56	2.00	1.50	0.63	6.75			5.13	3.25
8.00	8.50	0.75	12		0.69	2.00	1.50	0.63	7.57			5.13	3.25

Style 1
Standard Male

The "KK" male thread ends provide a shoulder surface for mounting accessories. These rod ends are recommended for use when design permits.

Style 2
Oversized Male

The "CC" male thread ends provide a shoulder surface for mounting accessories. These rod ends are recommended for use when design permits.

Style 3
Standard Female

Female thread used with male accessories.

Style 4
Self Aligning Coupler

Used with Self-Aligning accessory for fast, close radial alignment.

Style 5
Special

Special rod ends made to suit customer requirements are available. Submit dimensional sketch or accurate description when desired.

VARIABLE ROD DIMENSIONS							+ Stroke
Bore	Rod Dia	V	W	Y	WF	RP	ZF
1.50	0.63	0.25	0.63	1.97	1.00	2.00	5.00
	1.00	0.50	1.00	2.34	1.38	SQ.	5.38
2.00	0.63	0.25	0.63	1.97	1.00	2.00	5.00
	1.00	0.50	1.00	2.34	1.38	2.38	5.38
	1.38	0.63	1.25	2.59	1.63	SQ.	5.63
2.50	0.63	0.25	0.63	1.94	1.00	2.00	5.13
	1.00	0.50	1.00	2.31	1.38	2.38	5.50
	1.38	0.63	1.25	2.56	1.63	2.94	5.75
	1.75	0.75	1.50	2.81	1.88	SQ.	6.00
3.25	1.00	0.25	0.75	2.44	1.38	2.38	6.25
	1.38	0.38	1.00	2.69	1.63	2.94	6.50
	1.75	0.50	1.25	2.94	1.88	3.38	6.75
4.00	2.00	0.50	1.38	3.06	2.00	3.63	6.88
	1.00	0.25	0.75	2.44	1.38	2.38	6.25
	1.38	0.38	1.00	2.69	1.63	2.94	6.50
	1.75	0.50	1.25	2.94	1.88	3.38	6.75
5.00	2.00	0.50	1.38	3.06	2.00	3.63	6.88
	1.00	0.25	0.75	2.43	1.38	2.38	6.50
	1.38	0.38	1.00	2.68	1.63	2.94	6.75
	1.75	0.50	1.25	2.93	1.88	3.38	7.00
6.00	2.00	0.50	1.38	3.05	2.00	3.63	7.13
	1.38	0.25	0.88	2.81	1.63	2.94	7.38
	1.75	0.38	1.13	3.06	1.88	3.38	7.63
	2.00	0.38	1.25	3.19	2.00	3.63	7.63
7.00	2.50	0.50	1.50	3.44	2.25	4.19	8.00
	1.38	0.25	1.63	2.81	1.63	2.94	6.75
	1.75	0.38	1.88	3.06	1.88	3.38	7.00
	2.00	0.38	2.00	3.19	2.00	3.63	7.13
8.00	2.50	0.50	2.25	3.44	2.25	4.19	7.38
	1.38	0.25	1.63	2.81	1.63	2.94	6.75
	1.75	0.38	1.88	3.06	1.88	3.38	7.00
	2.00	0.38	2.00	3.19	2.00	3.63	7.13
	2.50	0.50	2.25	3.44	2.25	4.19	7.38

STANDARD ROD DIMENSIONS						
	0.63	1.00	1.38	1.75	2.00	2.50
A	0.75	1.13	1.63	2.00	2.25	3.00
B	1.12	1.50	2.00	2.37	2.62	3.12
C	0.38	0.50	0.63	0.75	0.88	1.00
D	0.50	0.88	1.13	1.50	1.69	2.06
KK	7/16-20	3/4-16	1-14	1 1/4-12	1 1/2-12	1 7/8-12
CC	1/2-20	7/8-14	1 1/4-12	1 1/2-12	1 3/4-12	2 1/4-12
AC	1.13	1.63	1.75	2.00	2.63	3.25
AD	0.63	0.94	1.06	1.31	1.69	1.94
AE	0.25	0.38	0.38	0.50	0.63	0.75
AF	0.38	0.69	0.88	1.13	1.38	1.75
AL	1.75	2.50	2.75	3.13	3.75	4.50

Important Note:

Style 1 Rod End is standard and will be supplied unless otherwise specified. Alternate styles 2, 3, and 4 are available at no extra charge. Additional "WF" and "A" can be supplied at an additional charge.

Four Full-Wrench-Flats

Cylinders can be produced with four full-wrench-flats for convenience during cylinder installation or replacement, as well as, a time and money saver. The flat is positioned for a good wrench hold using normal tools.

Spanner Wrench Holes

4" rod and larger have spanner wrench holes in place of wrench flats.

ROD END TRUNNION MOUNT MT1

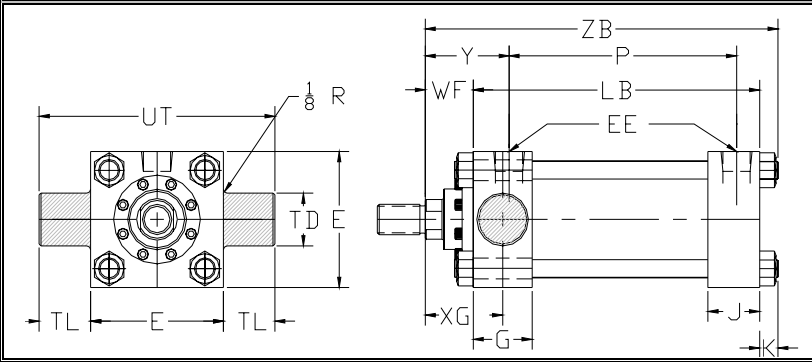

Recommended Usage

Rod and Cap End Trunnion Mount (MT1 and MT2)

Cap and Head Trunnion mounts can be used in both compression (push) and tension (pull). Head Trunnion Mounts (MT1) provide longer maximum strokes than Cap Trunnion Mounts (MT2), when used in compression. These mounts are for use in applications in which the stroke travels in a curved path within one plane.

CAP END TRUNNION MOUNT MT2

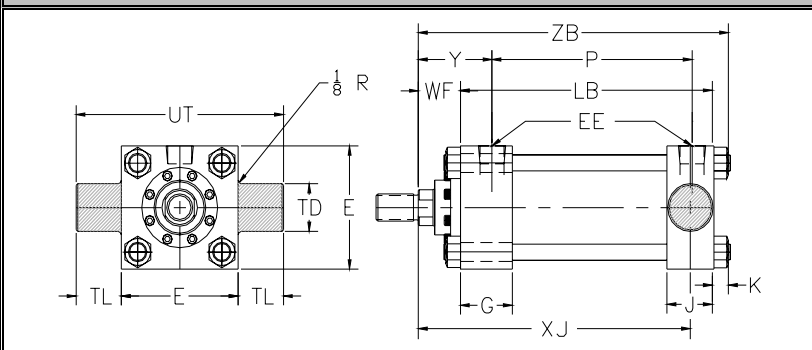

Recommended Mounting Practices

Attention should be given to proper mounting of trunnion cylinders. It is recommended that rigidly mounted pillow blocks with bearings at least as long as the trunnion pins be used and be installed as close to the trunnion shoulder as possible, to prevent an "egging" effect on the mating part.

Note that pins are designed for shear loads only, not bending loads. Lubrication should be provided to the pins.

CENTER TRUNNION MOUNT MT4

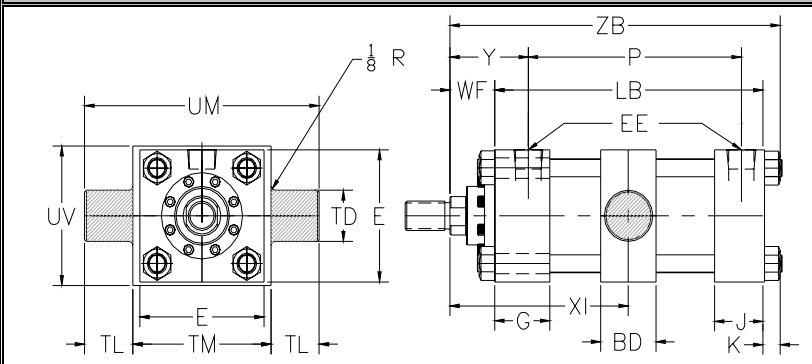

Recommended Usage

Center Trunnion Mount (MT4)

Center Trunnion mounts can be used in both compression (push) and tension (pull) and is designed for longer stroke applications in which the travel is in a curved path within one plane.

In horizontal applications to balance loads, the recommended XI dimension (rod shoulder to centerline of trunnion pin) equals 1/2 the stroke. For other recommendations refer to the MT1 and MT2 mounts above.

Customer must specify "XI" dimension.

Centerline Lug Mount Dimensions

BORE	E	EE-NPT	EE-SAE	G	J	K	TD	TL	UT	BD	TM	UM	UV	+ Stroke	
														LB	P
1.50	2.00	0.38	6	1.50	1.00	0.31	1.00	1.00	4.00	1.25	2.50	4.50	2.50	3.63	2.22
2.00	2.50	0.38	6	1.50	1.00	0.31	1.00	1.00	4.50	1.50	3.00	5.00	3.00	3.63	2.22
2.50	3.00	0.38	6	1.50	1.00	0.31	1.00	1.00	5.00	1.50	3.50	5.50	3.50	3.75	2.38
3.25	3.75	0.50	8	1.75	1.25	0.38	1.00	1.00	5.75	2.00	4.50	6.50	4.25	4.25	2.63
4.00	4.50	0.50	8	1.75	1.25	0.38	1.00	1.00	6.50	2.00	5.25	7.25	5.00	4.25	2.63
5.00	5.50	0.50	8	1.75	1.25	0.50	1.00	1.00	7.50	2.00	6.25	8.25	6.00	4.50	2.89
6.00	6.50	0.75	12	2.00	1.50	0.50	1.38	1.38	9.25	2.50	7.63	10.38	7.00	5.00	3.13
7.00	7.50	0.75	12	2.00	1.50	0.63	1.38	1.38	10.25					5.13	3.25
8.00	8.50	0.75	12	2.00	1.50	0.63	1.38	1.38	11.25					5.13	3.25

Caution:

Trunnion mount cylinders in bore sizes 5" through 8" with oversized piston rods should not be used over 2,000 psi. If your application demands higher pressure, consult the factory.

Style 1
Standard Male

The "KK" male thread ends provide a shoulder surface for mounting accessories. These rod ends are recommended for use when design permits.

Style 2
Oversized Male

The "CC" male thread ends provide a shoulder surface for mounting accessories. These rod ends are recommended for use when design permits.

Style 3
Standard Female

Female thread used with male accessories.

Style 4
Self Aligning Coupler

Used with Self-Aligning accessory for fast, close radial alignment.

Style 5
Special

Special rod ends made to suit customer requirements are available. Submit dimensional sketch or accurate description when desired.

VARIABLE ROD DIMENSIONS							Minimum	+ Stroke	
Bore	ROD DIA.	V	Y	WF	RP	XG	XI	ZB	XJ
1.50	0.63	0.25	1.97	1.00	2.00	1.75	3.13	4.94	4.13
	1.00	0.50	2.34	1.38	SO.	2.13	3.50	5.31	4.50
2.00	0.63	0.25	1.97	1.00	2.00	1.75	3.25	4.94	4.13
	1.00	0.50	2.34	1.38	2.38	2.13	3.63	5.31	4.50
2.50	1.38	0.63	2.59	1.63	SO.	2.38	3.88	5.56	4.75
	0.63	0.25	1.94	1.00	2.00	1.75	3.25	5.06	4.25
	1.00	0.50	2.31	1.38	2.38	2.13	3.63	5.44	4.63
3.25	1.38	0.63	2.56	1.63	2.94	2.38	3.88	5.69	4.88
	1.75	0.75	2.81	1.88	SO.	2.63	4.13	5.94	5.13
	1.00	0.25	2.44	1.38	2.38	2.25	4.13	6.00	5.00
4.00	1.38	0.38	2.69	1.63	2.94	2.50	4.38	6.25	5.25
	1.75	0.50	2.94	1.88	3.38	2.75	4.63	6.50	5.50
	2.00	0.50	3.06	2.00	3.63	2.88	4.75	6.63	5.63
5.00	1.00	0.25	2.43	1.38	2.38	2.25	4.13	6.38	5.25
	1.38	0.38	2.68	1.63	2.94	2.50	4.38	6.63	5.50
	1.75	0.50	2.93	1.88	3.38	2.75	4.63	6.88	5.75
6.00	2.00	0.50	3.05	2.00	3.63	2.88	4.75	7.00	5.88
	1.38	0.25	2.81	1.63	2.94	2.63	4.88	7.13	5.88
	1.75	0.38	3.06	1.88	3.38	2.88	5.13	7.38	6.13
7.00	2.00	0.38	3.19	2.00	3.63	3.00	5.25	7.50	6.25
	2.50	0.50	3.44	2.25	4.19	3.25	5.50	7.75	6.50
	1.38	0.25	2.81	1.63	2.94			7.38	6.00
8.00	1.75	0.38	3.06	1.88	3.38			7.63	6.25
	2.00	0.38	3.19	2.00	3.63			7.75	6.38
	2.50	0.50	3.44	2.25	4.19			8.00	6.63
8.00	1.38	0.25	2.81	1.63	2.94			7.38	6.00
	1.75	0.38	3.06	1.88	3.38			7.63	6.25
	2.00	0.38	3.19	2.00	3.63			7.75	6.38
8.00	2.50	0.50	3.44	2.25	4.19			8.00	6.63

STANDARD ROD DIMENSIONS						
	0.63	1.00	1.38	1.75	2.00	2.50
A	0.75	1.13	1.63	2.00	2.25	3.00
B	1.12	1.50	2.00	2.37	2.62	3.12
C	0.38	0.50	0.63	0.75	0.88	1.00
D	0.50	0.88	1.13	1.50	1.69	2.06
KK	7/16-20	3/4-16	1-14	1 1/4-12	1 1/2-12	1 7/8-12
CC	1/2-20	7/8-14	1 1/4-12	1 1/2-12	1 3/4-12	2 1/4-12
AC	1.13	1.63	1.75	2.00	2.63	3.25
AD	0.63	0.94	1.06	1.31	1.69	1.94
AE	0.25	0.38	0.38	0.50	0.63	0.75
AF	0.38	0.69	0.88	1.13	1.38	1.75
AL	1.75	2.50	2.75	3.13	3.75	4.50

Important Note:

Style 1 Rod End is standard and will be supplied unless otherwise specified. Alternate styles 2, 3, and 4 are available at no extra charge. Additional "WF" and "A" can be supplied at an additional charge.

Four Full-Wrench-Flats

Cylinders can be produced with four full-wrench-flats for convenience during cylinder installation or replacement, as well as, a time and money saver. The flat is positioned for a good wrench hold using normal tools.

Spanner Wrench Holes

4" rod and larger have spanner wrench holes in place of wrench flats.

Double Rod End

DRE

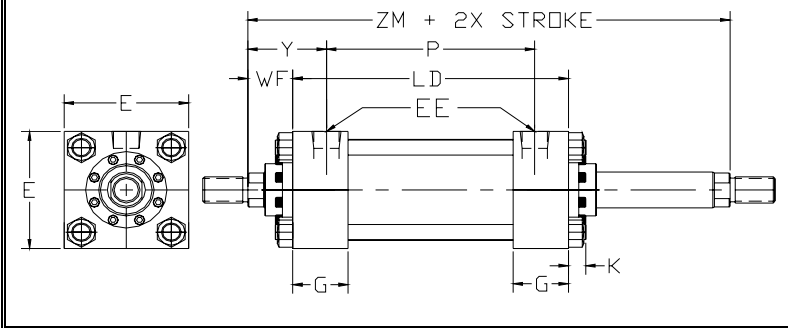

Recommended Applications for DRE

Double Rod End cylinders are specified for many applications, some of which include:

1. Simultaneous push and pull requirements
2. Both rod ends are fixed and the cylinder moves, such as on a machine slide
3. One rod serves to indicate position or to trip switches
4. Double rod end cylinders have rod bearings at each end and therefore offers greater resistance to deflection and side loading
5. Double rod end cylinders have the same effective piston area and volume when same rod diameter is specified

Double Rod End Mount Dimensions						+ Stroke	
BORE	E	EE-NPT	EE-SAE	G	K	LD	P
1.50	2.00	0.38	6	1.50	0.31	4.13	2.22
2.00	2.50	0.38	6	1.50	0.31	4.13	2.22
2.50	3.00	0.38	6	1.50	0.31	4.25	2.38
3.25	3.75	0.50	8	1.75	0.38	4.75	2.63
4.00	4.50	0.50	8	1.75	0.38	4.75	2.63
5.00	5.50	0.50	8	1.75	0.50	5.00	2.89
6.00	6.50	0.75	12	2.00	0.50	5.50	3.13
7.00	7.50	0.75	12	2.00	0.63	5.63	3.25
8.00	8.50	0.75	12	2.00	0.63	5.63	3.25

When the rod ends of a double rod end cylinder are not the same, be certain to identify which end is which in relation to the mount.

Water Service

When using water as an operating medium, corrosion-resistant plating is applied to heads, caps and pistons. Stainless steel piston rods with hard chrome plating is highly recommended. When using a stainless steel piston rod, special consideration must be given to the maximum operating pressure and speed conditions due to the material tensile strength.

Tandem Cylinders

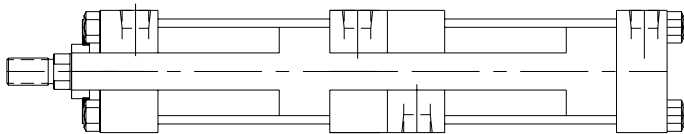

Two pistons connected to a common rod, resulting in twice the force of a single cylinder. This is an economical way to multiply force without increasing bore size or operating pressure.

Integral Shock Absorber

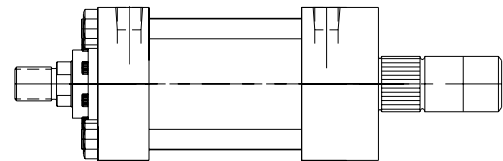

When piston speeds exceed even special cushion capabilities, integral shock absorbers help control the loads.

Multi-Stage Cylinders

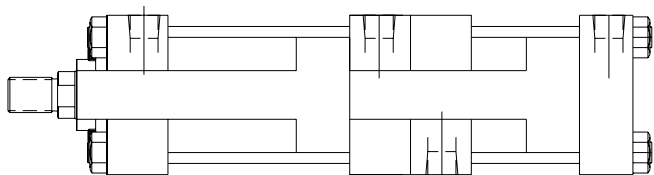

Multi-Stage cylinders offer multiple, positive strokes by pressurizing one cylinder, the other or both. The single rod end cylinder configuration includes independent, double acting rod assemblies facing in the same direction to provide multiple stroke positions or to boost output force by controlling actuating sequence.

Pressure Intensifier

A pressure intensifier amplifies the available line pressure in order to perform work requiring much higher pressure. It operates a hydraulic cylinder without the need for a hydraulic power unit.

Duplex or Back to Back Cylinders

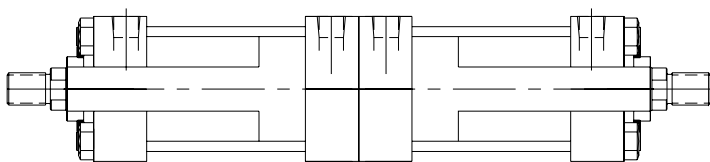

Back to Back Cylinders - Independent double acting cylinders connected by common tie rods with piston rods facing opposite directions form a unit capable of multiple stroke positions constructed from standard components.

Air-Oil Tanks

Used as a source of oil to compensate for any loss in a hydraulic system. They provide hydraulic pressure to return the cylinder to its starting position and an outlet for entrapped air in the hydraulic system. The Air-Oil Tank contains air on top of oil. The air is under line pressure from the same source as the air used to operate the booster. A sight-gauge is mounted on the of JIT Air-Oil tanks so that the level of oil in reserve can be readily observed. When required, hydraulic fluid may be added through a port in the top of the tank after shutting off air pressure.

Style 1
Standard Male

The "KK" male thread ends provide a shoulder surface for mounting accessories. These rod ends are recommended for use when design permits.

Style 2
Oversized Male

The "CC" male thread ends provide a shoulder surface for mounting accessories. These rod ends are recommended for use when design permits.

Style 3
Standard Female

Female thread used with male accessories.

Style 4
Self Aligning Coupler

Used with Self-Aligning accessory for fast, close radial alignment.

Style 5
Special

Special rod ends made to suit customer requirements are available. Submit dimensional sketch or accurate description when desired.

VARIABLE ROD DIMENSIONS						+ Stroke
Bore	Rod Dia	V	Y	WF	RP	ZM
1.50	0.63	0.25	1.97	1.00	2.00	6.13
	1.00	0.50	2.34	1.38	SQ.	6.88
2.00	0.63	0.25	1.97	1.00	2.00	6.13
	1.00	0.50	2.34	1.38	2.38	6.88
	1.38	0.63	2.59	1.63	SQ.	7.38
2.50	0.63	0.25	1.94	1.00	2.00	6.25
	1.00	0.50	2.31	1.38	2.38	7.00
	1.38	0.63	2.56	1.63	2.94	7.50
	1.75	0.75	2.81	1.88	SQ.	8.00
3.25	1.00	0.25	2.44	1.38	2.38	7.50
	1.38	0.38	2.69	1.63	2.94	8.00
	1.75	0.50	2.94	1.88	3.38	8.50
4.00	2.00	0.50	3.06	2.00	3.63	8.75
	1.00	0.25	2.44	1.38	2.38	7.50
	1.38	0.38	2.69	1.63	2.94	8.00
5.00	1.75	0.50	2.94	1.88	3.38	8.50
	2.00	0.50	3.06	2.00	3.63	8.75
	1.00	0.25	2.43	1.38	2.38	7.75
6.00	1.38	0.38	2.68	1.63	2.94	8.25
	1.75	0.50	2.93	1.88	3.38	8.75
	2.00	0.50	3.05	2.00	3.63	9.00
	1.38	0.25	2.81	1.63	2.94	8.75
7.00	1.75	0.38	3.06	1.88	3.38	9.25
	2.00	0.38	3.19	2.00	3.63	9.50
	2.50	0.50	3.44	2.25	4.19	10.00
8.00	1.38	0.25	2.81	1.63	2.94	8.88
	1.75	0.38	3.06	1.88	3.38	9.38
	2.00	0.38	3.19	2.00	3.63	9.63
	2.50	0.50	3.44	2.25	4.19	10.13

STANDARD ROD DIMENSIONS						
	0.63	1.00	1.38	1.75	2.00	2.50
A	0.75	1.13	1.63	2.00	2.25	3.00
B	1.12	1.50	2.00	2.37	2.62	3.12
C	0.38	0.50	0.63	0.75	0.88	1.00
D	0.50	0.88	1.13	1.50	1.69	2.06
KK	7/16-20	3/4-16	1-14	1 1/4-12	1 1/2-12	1 7/8-12
CC	1/2-20	7/8-14	1 1/4-12	1 1/2-12	1 3/4-12	2 1/4-12
AC	1.13	1.63	1.75	2.00	2.63	3.25
AD	0.63	0.94	1.06	1.31	1.69	1.94
AE	0.25	0.38	0.38	0.50	0.63	0.75
AF	0.38	0.69	0.88	1.13	1.38	1.75
AL	1.75	2.50	2.75	3.13	3.75	4.50

Important Note:

Style 1 Rod End is standard and will be supplied unless otherwise specified. Alternate styles 2, 3, and 4 are available at no extra charge. Additional "WF" and "A" can be supplied at an additional charge.

Four Full-Wrench-Flats

Cylinders can be produced with four full-wrench-flats for convenience during cylinder installation or replacement, as well as, a time and money saver. The flat is positioned for a good wrench hold using normal tools.

Spanner Wrench Holes

4" rod and larger have spanner wrench holes in place of wrench flats.

Rod Clevis

Part No	Rod Dia	KK	CD	CB	CW	CE	A	ER
RC044	5/8	7/16-20	0.50	0.77	0.50	1.50	0.75	0.50
RC050	5/8	1/2-20	0.50	0.77	0.50	1.50	0.75	0.50
RC075	1	3/4-16	0.75	1.27	0.63	2.38	1.13	0.75
RC087	1	7/8-14	1.00	1.52	0.75	2.94	1.63	1.00
RC100	1 3/8	1-14	1.00	1.52	0.75	3.13	1.63	1.00
RC125	1 3/8	1 1/4-12	1.38	2.03	1.00	4.13	2.00	1.38
RC150	2	1 1/2-12	1.75	2.53	1.25	4.50	2.25	1.75
RC175	2	1 3/4-12	2.00	2.53	1.25	5.50	3.00	2.00
RC187	2 1/2	1 7/8-12	2.00	2.53	1.25	5.50	3.00	2.00
RC225	3	2 1/4-12	2.50	3.03	1.50	6.50	3.50	2.50
RC250	3 1/2	2 1/2-12	3.00	3.03	1.50	6.75	3.50	2.75
RC275	4	3-12	3.50	4.03	2.00	8.50	4.50	3.50
RC325	4 1/2	3 1/4-12	3.50	4.03	2.00	8.50	4.50	3.50
RC350	5	3 1/2-12	3.50	4.03	2.00	8.50	4.50	3.50
RC400	5 1/2	4-12	4.00	4.53	2.25	10.00	5.50	4.00

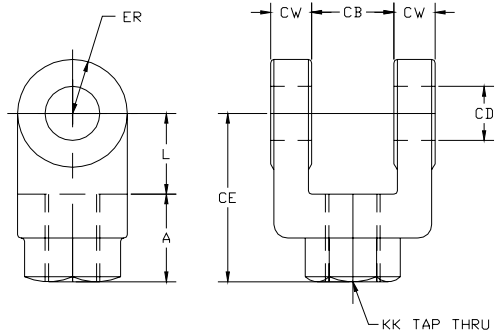

Rod Eye

Part No	Rod Dia	KK	CD	CB	CA	A	ER
FE044	5/8	7/16-20	0.50	0.75	1.50	0.75	0.63
FE050	5/8	1/2-20	0.50	0.75	1.50	0.75	0.63
FE075	1	3/4-16	0.75	1.25	2.06	1.13	0.88
FE087	1	7/8-14	1.00	1.50	2.38	1.13	1.44
FE100	1	1-14	1.00	1.50	2.81	1.63	1.19
FE125	1 3/8	1 1/4-12	1.38	2.00	3.44	2.00	1.56
FE150	1 3/4	1 1/2-12	1.75	2.50	4.00	2.25	2.00
FE175		1 3/4-12	2.00	2.50	4.38	2.25	2.88
FE187	2 1/2	1 7/8-12	2.00	2.50	5.00	3.00	2.50
FE225	2 1/2	2 1/4-12	2.50	3.00	5.81	3.50	2.81
FE250	3 1/2	2 1/2-12	3.00	3.00	6.13	3.50	3.25
FE275	4	3-12	3.50	4.00	7.63	4.50	3.88
FE325	4 1/2	3 1/4-12	3.50	4.00	7.63	4.50	3.88
FE350	5	3 1/2-12	3.50	4.00	7.63	5.00	3.88
FE400	5 1/2	4-12	4.00	4.50	9.13	5.50	4.44

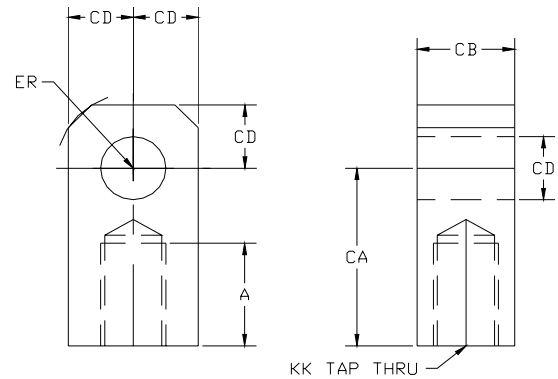

Pivot Pin

Part No.	CL	CD	A	D	E	CL	B
PP050	1.88	0.50	0.47	0.04	0.11	1.88	2.09
PP075	2.63	0.75	0.70	0.05	0.13	2.63	2.88
PP100	3.13	1.00	0.94	0.05	0.13	3.13	3.38
PP138	4.19	1.38	1.29	0.06	0.15	4.19	4.49
PP175	5.19	1.75	1.89	0.07	0.18	5.19	5.55
PP200	5.19	2.00	2.36	0.09	0.22	5.19	5.55
PP250	6.19	2.50	2.84	0.10	0.27	6.19	6.63
PP300	6.25	3.00	3.32	0.12	0.36	6.25	6.78
PP350	8.13	3.50	3.79	0.12	0.36	8.13	8.85
PP400	9.13	4.00	4.00	4.00	4.00	9.13	9.85

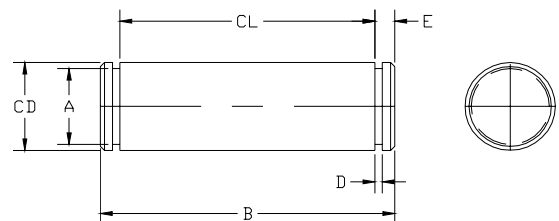

Pivot Pin furnished with (2) retainers.

Eye Bracket (High Pressure Hydraulic)

Part		Dimensions								
Number	Series	CD	CB	DD	E	F	FL	LR	M	R
EB050	1.50	0.50	0.75	0.41	2.50	0.38	1.13	0.75	0.50	1.63
EB075	2.0-2.5	0.75	1.25	0.53	3.50	0.63	1.88	1.25	0.75	2.56
EB100	3.25	1.00	1.50	0.66	4.50	0.75	2.25	1.50	1.00	3.25
EB138	4.00	1.38	2.00	0.66	5.00	0.88	3.00	2.13	1.38	3.81
EB175	5.00	1.75	2.50	0.91	6.50	0.88	3.13	2.25	1.75	4.95
EB200	6.00	2.00	2.50	1.06	7.50	1.00	3.50	2.50	2.00	5.75
EB250	7.00	2.50	3.00	1.19	8.50	1.00	4.00	3.00	2.50	6.59
EB300	8.00	3.00	3.00	1.31	9.50	1.00	4.25	3.25	3.00	7.50

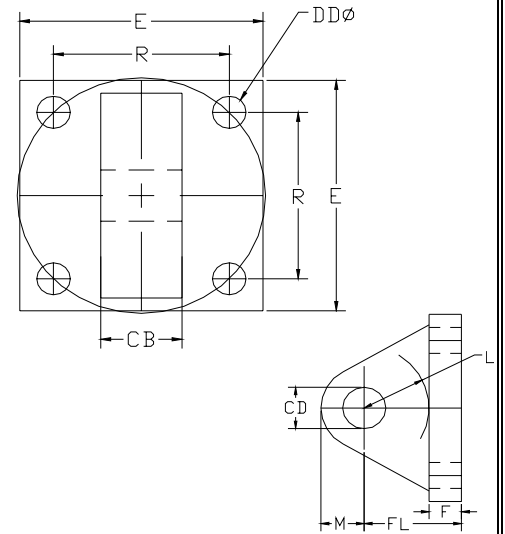

Eye Bracket (Air and Medium Pressure Hydraulic)

Part		Dimensions								
Number	Series	CD	CB	DD	E	F	FL	LR	M	R
EB050	1.5-2.5	0.50	0.75	0.41	2.50	0.38	1.13	0.75	0.50	1.63
EB075	3.25-5	0.75	1.25	0.53	3.50	0.63	1.88	1.25	0.75	2.56
EB100	6-8	1.00	1.50	0.66	4.50	0.75	2.25	1.50	1.00	3.25

Clevis Bracket (High Pressure Hydraulic)

Part		Dimensions								
Number	Series	CD	CB	BA	CW	DD	E	F	FL	M
CB050	1.50	0.50	0.77	1.63	0.50	3/8-24	2.50	0.38	1.13	0.50
CB075	2.0-2.5	0.75	1.27	2.56	0.63	1/2-20	3.50	0.63	1.88	0.75
CB100	3.25	1.00	1.52	3.25	0.75	5/8-18	4.50	0.75	2.25	1.00
CB138	4.00	1.38	2.03	3.81	1.00	5/8-18	5.00	0.88	3.00	1.38
CB175	5.00	1.75	2.53	4.94	1.25	7/8-14	6.50	0.88	3.13	1.75
CB200	6.00	2.00	2.53	5.75	1.25	1-14	7.50	1.00	3.50	2.00
CB250	7.00	2.50	3.03	6.59	1.50	1 1/8-12	8.50	1.00	4.00	2.50
CB300	8.00	3.00	3.03	7.50	1.50	1 1/4-12	9.50	1.00	4.25	2.75

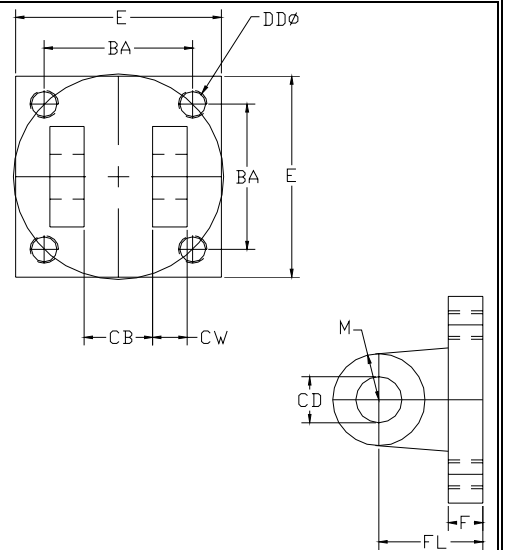

Clevis Bracket (Air and Medium Pressure Hydraulic)

Part		Dimensions								
Number	Series	CD	CB	BA	CW	DD	E	F	FL	M
CB050	1.5-2.5	0.50	0.77	1.63	0.50	3/8-24	2.50	0.38	1.13	0.50
CB075	4-12	0.75	1.27	2.56	0.63	1/2-20	3.50	0.63	1.88	0.75
CB100	6-8	1.00	1.52	3.25	0.75	5/8-18	4.50	0.75	2.25	1.00

ALIGNMENT COUPLER

Part		DIMENSIONS						
Number	A	B	C	D	E	F	G	H
AC044	7/16-20	1.25	2.00	0.50	0.75	0.63	0.56	1.13
AC050	1/2-20	1.25	2.00	0.50	0.75	0.63	0.56	1.13
AC075	3/4-16	1.75	2.31	0.31	1.13	0.97	0.88	1.50
AC087	7/8-14	1.75	2.31	0.31	1.13	0.97	0.88	1.50
AC100	1-14	2.50	2.94	0.50	1.63	1.38	1.25	2.25
AC125	1 1/4-12	2.50	2.94	0.50	1.63	1.38	1.25	2.25
AC150	1 1/2-12	3.25	4.38	0.81	2.25	1.75	1.50	3.00
AC175	1 3/4-12	3.25	4.38	0.81	2.25	1.75	1.50	3.00
AC187	1 7/8-12	3.75	5.44	0.69	3.00	2.25	1.88	3.50
AC225	2 1/4-12	6.75	6.38	3.25	3.50	2.75	2.38	2.88
AC250	2 1/2-12	7.00	6.50	4.00	3.50	3.25	2.88	3.38

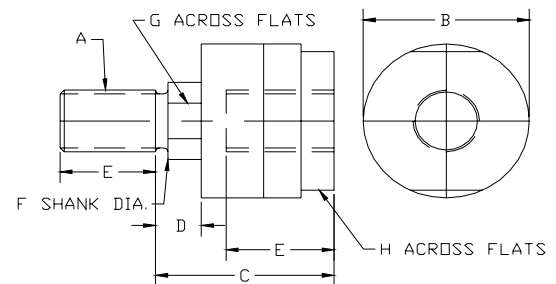

SELF-ALIGNING ROD EYE (High Pressure Hydraulic)

Part	H	DIMENSIONS							
Number	Series	KK	A	CD	CE	EX	ER	LE	JL
SAE044	1.50	7/16-20	0.69	0.50	0.88	0.44	0.88	0.75	0.88
SAE075	2.0-2.5	3/4-16	1.00	0.75	1.25	0.03	1.25	1.06	1.31
SAE100	3.25	1-14	1.50	1.00	1.88	0.88	1.38	1.44	1.50
SAE125	4.00	1 1/4-12	2.00	1.38	2.13	1.19	1.81	1.88	2.00
SAE150	5.00	1 1/2-12	2.13	1.75	2.50	1.53	2.19	2.13	2.25
SAE187	6.00	1 7/8-12	2.88	2.00	2.75	1.75	2.63	2.50	2.75

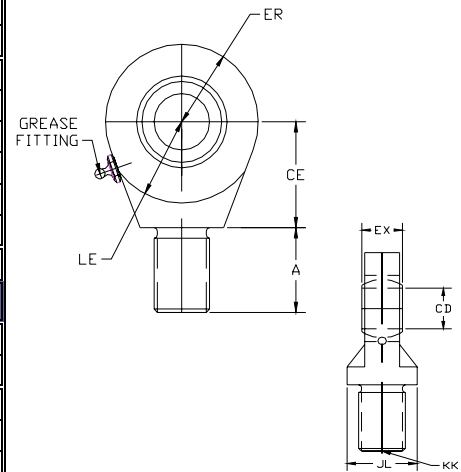

SELF-ALIGNING ROD EYE (Pneumatic and Low Pressure Hydraulic)

Part	A & LH	DIMENSIONS							
Number	Series	KK	A	CD	CE	EX	ER	LE	JL
SAE044	1.5-2.5	7/16-20	0.69	0.50	0.88	0.44	0.88	0.75	0.88
SAE075	3.25-5	3/4-16	1.00	0.75	1.25	0.03	1.25	1.06	1.31
SAE100	6-8	1-14	1.50	1.00	1.88	0.88	1.38	1.44	1.50

SELF-ALIGNING CLEVIS BRACKET

Part	H	DIMENSIONS								
Number	Series	CD	E	F	M	R	CF	CW	DD	FL
SCB050	1.50	0.50	3.00	0.50	0.50	2.05	0.44	0.50	0.41	1.50
SCB075	2.0-2.5	0.75	3.75	0.62	0.88	2.76	0.66	0.62	0.53	2.00
SCB100	3.25	1.00	5.50	0.75	1.00	4.10	0.88	0.75	0.53	2.50
SCB125	4.00	1.38	6.50	0.88	1.38	4.95	1.19	1.00	0.66	3.50
SCB150	5.00	1.75	8.50	1.25	1.75	6.58	1.53	1.25	0.91	4.50
SCB187	6.00	2.00	10.62	1.50	2.00	7.92	1.75	1.50	0.91	5.00

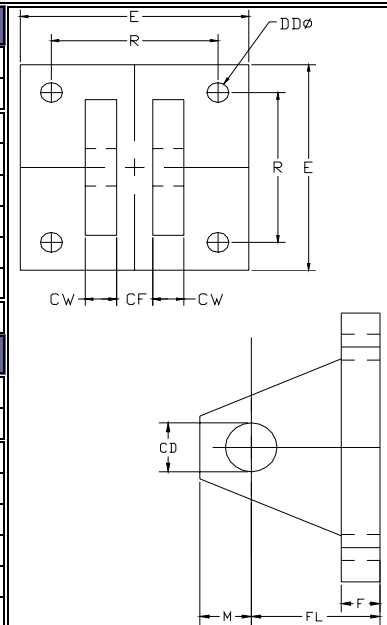

SELF-ALIGNING CLEVIS BRACKET

Part	A & LH	DIMENSIONS								
Number	Series	CD	E	F	M	R	CF	CW	DD	FL
SCB050	3-12	0.50	3.00	0.50	0.50	2.05	0.44	0.50	0.41	1.50
SCB075	3.25-5	0.75	3.75	0.62	0.88	2.76	0.66	0.62	0.53	2.00
SCB100	6-8	1.00	5.50	0.75	1.00	4.10	0.88	0.75	0.53	2.50
SCB125	4-12	1.38	6.50	0.88	1.38	4.95	1.19	1.00	0.66	3.50
SCB150		1.75	8.50	1.25	1.75	6.58	1.53	1.25	0.91	4.50
SCB187		2.00	10.62	1.50	2.00	7.92	1.75	1.50	0.91	5.00

SA PIVOT PINS

Part	H	A & LH	DIMENSIONS	
Number	Series	Series	CD	CL
PP050SA	1.50	1.5-2.5	0.500	1.56
PP075SA	2.0-2.5	3.25-5	0.750	2.03
PP100SA	3.25	6-8	1.000	2.50
PP138SA	4.00		1.374	3.31
PP175SA	5.00		1.750	4.22
PP200SA	6.00		2.000	4.94

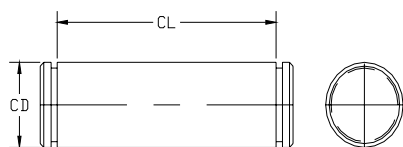

Pivot Pin furnished with (2) retainers.



The JIT Certified Guarantee

We guarantee that all cylinders ordered from this catalog will be built to the exact dimensions specified. All dimensions have been certified to be correct, and thus it is not necessary to request certified drawings

Safety Coupler

Safety Couplers create a stronger connection than a standard threaded rod end and provide closer radial alignment making installation quicker and results in less wear of component parts by allowing for radial misalignment. Some additional Safety Coupler advantages include:

1. Faster close radial alignment important for long cylinder life
2. Less critical rod end to machine attachment
3. Use with any JIT cylinder with 5/8" or larger rod diameter
4. Use with no extra cost JIT Style 4 rod end
5. Faster cylinder installation and removal
6. Better force distribution on push and pull strokes
7. For use with fixed mount cylinders

Part No.	Rod Dia	Dimensions									
		B	C	D	H	I	J	L	M	N	P
SC062	0.63	0.41	1.50	0.56	45°	90°	0.22	4	1.13	0.25	0.66
SC100	1.00	0.75	2.00	0.88	30°	60°	0.28	6	1.50	0.38	1.06
SC138	1.38	0.94	2.50	1.00	30°	60°	0.34	6	2.00	0.38	1.44
SC175	1.75	1.19	3.00	1.25	22.5°	45°	0.34	8	2.38	0.50	1.81
SC200	2.00	1.44	3.50	1.63	15°	30°	0.41	12	2.69	0.63	2.06
SC250	2.50	1.88	4.00	2.88	15°	30°	0.41	12	3.19	0.75	2.63
SC300	3.00	2.38	5.00	2.38	15°	30°	0.53	12	4.00	0.88	3.13
SC350	3.50	2.63	5.88	2.63	15°	30°	0.66	12	4.69	1.00	3.63
SC400	4.00	3.13	6.38	2.63	15°	30°	0.66	12	5.19	1.00	4.13
SC450	4.50	3.63	6.88	3.13	15°	30°	0.66	12	5.69	1.50	4.63
SC500	5.00	4.00	7.38	3.13	15°	30°	0.66	12	6.19	1.50	5.13
SC550	5.50	4.50	8.25	3.88	15°	30°	0.78	12	6.88	1.88	5.63

Weld Plate

Also available as a convenient accessory (optional at extra cost) is a Weld Plate to match each Safety Coupler. The Weld Plate provides the perfect answer to customers who prefer to weld a pre-drilled and tapped, properly sized plate to the machine, rather than laying out, drilling and tapping each hole in the machine. The Weld Plate is equipped with an accurately drilled locator pin hole to facilitate fast, close tolerance positioning. Advantages of our Safety Coupler option include:

Part No.	Size	E	F	G	H	I	K	L	M
WP062	0.63	0.50	2.00	0.25	45°	90°	10-24	4	1.13
WP100	1.00	0.50	2.50	0.25	30°	60°	1/4-20	6	1.50
WP137	1.38	0.63	3.00	0.25	30°	60°	5/16-18	6	2.00
WP175	1.75	0.63	4.00	0.25	22.5°	45°	5/16-18	8	2.38
WP200	2.00	0.75	4.00	0.38	15°	30°	3/8-16	12	2.69
WP250	2.50	0.75	4.50	0.38	15°	30°	3/8-16	12	3.19
WP300	3.00	1.00	5.50	0.38	15°	30°	1/2-13	12	4.00
WP350	3.50	1.00	7.00	0.38	15°	30°	5/8-11	12	4.69
WP400	4.00	1.00	7.00	0.38	15°	30°	5/8-11	12	5.19
WP450	4.50	1.00	8.00	0.38	15°	30°	5/8-11	12	5.69
WP500	5.00	1.00	8.00	0.38	15°	30°	5/8-11	12	6.19
WP550	5.50	1.25	9.00	0.38	15°	30°	3/4-10	12	6.88

Sealing Solutions and Replacement Seal Kits

A Series

SEAL REPLACEMENT

Our gland design allows all rod seals, wipers, 'O' rings, and back-up washers to be easily removed from every standard gland regardless of rod size. Note that Gland Seal Kits have all seals properly loaded into a JIT Cylinders gland.

Polyurethane

Polyurethane seals can be supplied for any bore size.

Nitrile

Nitrile seals are standard and can be supplied for any bore size. The recommended operating temperature range is 10 degrees F. (23 degrees C.) to +165 degrees F. (+74 degrees C).

Viton Seals

Viton seals can be supplied for any bore size. Viton is suitable for higher temperature requirements within a range of 10 degrees F. (23 degrees C) to +250 degrees F. (+121 degrees C).

Custom Sealing Solution

JIT Cylinders designs and supplies sealing solutions for the most demanding applications. From exotic operating mediums to extremely high or low temperatures and pressures, we can design and manufacture cylinders that can operate effectively within almost any environment. Contact our engineering department to discuss your unique applications as we strive to supply responsive solutions to solve your application requirements.

High Pressure Pneumatic Seal Kits

Rod Diameter	Standard		Viton	
	Gland Kit	Rod Seal Kit	Gland Kit	Rod Seal Kit
0.625	KAG06	KAR06	KAGV06	KARV06
1	KAG10	KAR10	KAGV10	KARV10
1.375	KAG13	KAR13	KAGV13	KARV13
1.75	KAG17	KAR17	KAGV17	KARV17
2	KAG20	KAR20	KAGV20	KARV20
2.5	KAG25	KAR25	KAGV25	KARV25
3	KAG30	KAR30	KAGV30	KARV30
3.5	KAG35	KAR35	KAGV35	KARV35
4	KAG40	KAR40	KAGV40	KARV40
4.5	KAG45	KAR45	KAGV45	KARV45

Barrel Bore	Standard	Viton
	Piston Kit	Piston Kit
1.5	KAP15	KAPV15
2	KAP20	KAPV20
2.5	KAP25	KAPV25
3.25	KAP32	KAPV32
4	KAP40	KAPV40
5	KAP50	KAPV50
6	KAP60	KAPV60
7	KAP70	KAPV70
8	KAP80	KAPV80

Contents of Each Seal Kit

Gland Seal Kit	Rod Seal Kit	Piston Seal Kit
Gland	Rod Seal	Piston Seals (2)
Rod Seal	Rod Wiper	Barrel Seals (2)
Rod Wiper	Gland O.D. Seal	
Gland O.D. Seal	O.D. Backup	
O.D. Backup		

Warranty

JIT Cylinders, Inc. warrants every product of its manufacture to be of proper materials and first class workmanship. We agree to repair or replace, F.O.B. factory, but not to remove or install in the field, any perishable soft goods such as seals, which fail within a six-month period after shipment, normal wear accepted. We warrant for one year from date of shipment, all other parts which fail because of defective materials or workmanship. JIT assumes no responsibility for work done or expenses incurred, in the field, pertaining to such repairs or replacements, except upon written authority from our home office. Components not produced by JIT are subject only to the warranty extended to JIT by their respective manufacturer. When orders have been correctly filled, there shall be no returns without JIT's approval. Such returns will be subject to a restocking charge.

Return Goods Authorization (RGA)

All returns to JIT Cylinders must be accompanied with a Return Goods Authorization Number. A Return Goods Authorization Number may be obtained by contacting the plant. JIT Cylinders will inquire into why the return is being made and a number will be assigned at that time. Paperwork will be completed by JIT Cylinders giving details of the return from the information supplied by the customer or distributor. At the time the return is received the RGA number will be matched to the proper paperwork. This allows entry of the return without further questions or delays.

Quality Excellence Policy

We at JIT Cylinders are committed to serving the needs of our customers, as our name implies, Just-In-Time. We are committed to providing products and services which meet application requirements and are engineered for superior performance and reliability. We will achieve this through quality excellence in everything we do. Each task must be performed in conformance to requirements, and systems must be established which assure error-free performance in every area of manufacture. We understand that "quality excellence" depends on the personal performance of each employee. Because of this the entire management team and each member of manufacturing is dedicated and personally involved in the quality improvement process. We are dedicated to a policy of providing quality products and services that fully satisfy our customers' needs. We subscribe to the following quality absolutes:

Quality is defined as 100 percent conformance to requirements.

Our performance goal is to achieve error-free work in all functional areas.

Our system for causing quality is prevention.

We will track our progress in achieving total quality by measuring the price of non-conformance (waste).

Our primary objective will be continuous improvement.

100% Tested and Inspected!

Cylinders are first cycled at low pressure to remove air from the system and checked for proper mechanical action. During this procedure rod extension and stroke are measured. Test pressure is applied to cap and head ports in turn and under static pressure all joints are examined for leakage. Air lines are then fitted to cap and head in turn. The hydraulic fitting is removed from the non-pressurized port and a visual inspection made for air bubbles to indicate any piston seal leakage.

In addition, every cylinder is examined for:

Dimensional accuracy.

Proper unit switch actuation (if applicable).

Visual inspection for freedom of defects.

Proper assembly orientation.

Theoretical Forces Developed By Cylinders

A Series

How to Select the Right Cylinder

Maximum Pressure Ratings			
Bore Size	Medium Duty Service	Max Shock Service	3:1 Safety Factor (Yield)
1.5	150	250	250
2.0	150	250	250
2.5	150	250	250
3.25	150	250	250
4.0	150	250	250
5.0	150	250	250
6.0	150	250	250
7.0	150	250	250
8.0	150	250	250

A Series Cylinder Weight Chart							
Bore Size	Rod Dia.	Zero Stroke	Add per Inch of Stroke	Bore Size	Rod Dia.	Zero Stroke	Add per Inch of Stroke
1.5	0.625	6.0	0.35	4.0	2.0	32.0	2.2
	1.0	6.3	0.50	5.0	1.0	45.0	2.0
2.0	0.625	8.0	0.60		2.0	48.0	2.5
	1.375	9.0	1.00	6.0	1.375	70.0	2.5
2.5	0.625	11.0	0.90		2.5	74.0	3.8
	1.75	12.0	1.50	7.0	1.375	85.0	3.0
3.25	1.0	22.0	0.90		2.5	90.0	4.0
	2.0	23.0	2.00	8.0	1.375	100.0	4.0
4.0	1.0	30.0	1.20		2.5	115.0	5.4

Output Forces at Specific Input Pressures

Bore	Rod Dia	Push Area	Pull Area	Forces in Pounds at Various Pressures (PSI)																						
				50 PSI		75 PSI		100 PSI		125 PSI		150 PSI		200 PSI		250 PSI										
				Push	Pull	Push	Pull	Push	Pull	Push	Pull	Push	Pull	Push	Pull	Push	Pull									
1.5	0.63	1.77	1.46	88	73	133	110	177	146	221	183	265	219	353	292	442	365									
	1.00		0.79															40	59	79	99	119	158	198		
2	0.63	3.14	2.84	157	142	236	213	314	284	393	354	471	425	628	567	785	709									
	1.00		2.36															118	177	236	295	353	471	567	785	709
	1.38		1.66															83	124	166	207	249	331	414		
2.5	0.63	4.91	4.60	246	230	368	345	491	460	614	575	737	690	982	920	1,228	1,151									
	1.00		4.12															206	309	412	515	618	825	1,031		
	1.38		3.42															171	257	342	428	514	685	856		
	1.75		2.50															125	188	250	313	375	501	626		
3.25	1.00	8.30	7.51	415	376	623	563	830	751	1,038	939	1,245	1,127	1,660	1,502	2,075	1,878									
	1.38		6.81															341	511	681	851	1,022	1,362	1,703		
	1.75		5.89															295	442	589	736	884	1,178	1,473		
	2.00		5.15															258	387	515	644	773	1,031	1,289		
4	1.00	12.57	11.78	629	589	943	884	1,257	1,178	1,571	1,473	1,886	1,767	2,514	2,356	3,143	2,945									
	1.38		11.08															554	831	1,108	1,385	1,662	2,216	2,771		
	1.75		10.16															508	762	1,016	1,270	1,524	2,032	2,540		
	2.00		9.43															471	707	943	1,178	1,414	1,885	2,356		
5	1.00	19.64	18.85	982	943	1,473	1,414	1,964	1,885	2,455	2,356	2,946	2,828	3,928	3,770	4,910	4,713									
	1.38		18.15															908	1,361	1,815	2,269	2,723	3,630	4,538		
	1.75		17.23															862	1,292	1,723	2,154	2,585	3,446	4,308		
	2.00		16.49															825	1,237	1,649	2,062	2,474	3,299	4,123		
6	1.38	28.27	26.79	1,414	1,340	2,120	2,009	2,827	2,679	3,534	3,349	4,241	4,019	5,654	5,358	7,068	6,698									
	1.75		25.87															1,293	1,940	2,587	3,234	3,880	5,174	6,467		
	2.00		25.13															1,257	1,885	2,513	3,142	3,770	5,027	6,283		
	2.50		23.37															1,168	1,752	2,337	2,921	3,505	4,673	5,842		
7	1.38	38.49	37.00	1,925	1,850	2,887	2,775	3,849	3,700	4,811	4,625	5,774	5,550	7,698	7,400	9,623	9,250									
	1.75		36.08															1,804	2,706	3,608	4,510	5,412	7,216	9,020		
	2.00		35.34															1,767	2,651	3,534	4,418	5,301	7,069	8,836		
	2.50		33.58															1,679	2,518	3,358	4,197	5,036	6,715	8,394		
8	1.38	50.27	48.78	2,514	2,439	3,770	3,659	5,027	4,878	6,284	6,098	7,541	7,317	10,054	9,756	12,568	12,195									
	1.75		47.86															2,393	3,590	4,786	5,983	7,179	9,572	11,965		
	2.00		47.12															2,356	3,534	4,712	5,891	7,069	9,425	11,781		
	2.50		45.36															2,268	3,402	4,536	5,670	6,804	9,071	11,339		
10	1.75	78.54	76.14	3,927	3,807	5,891	5,710	7,854	7,614	9,818	9,517	11,781	11,420	15,708	15,227	19,635	19,034									
	2.00		75.40															3,770	5,655	7,540	9,425	11,310	15,080	18,850		
	2.50		73.63															3,682	5,522	7,363	9,204	11,045	14,726	18,408		
	3.00		71.47															3,574	5,360	7,147	8,934	10,721	14,294	17,868		
	3.50		68.92															3,446	5,169	6,892	8,615	10,338	13,784	17,230		
12	2.00	113.1	109.96	5,655	5,498	8,483	8,247	11,310	10,996	14,138	13,745	16,965	16,494	22,620	21,992	28,275	27,490									
	2.50		108.19															5,410	8,114	10,819	13,524	16,229	21,638	27,048		
	3.00		106.03															5,302	7,952	10,603	13,254	15,905	21,206	26,508		
	3.50		103.48															5,174	7,761	10,348	12,935	15,522	20,696	25,870		
	4.00		100.53															5,027	7,540	10,053	12,567	15,080	20,107	25,133		
14	2.50	153.9	148.99	7,695	7,450	11,543	11,174	15,390	14,899	19,238	18,624	23,085	22,349	30,780	29,798	38,475	37,248									
	3.00		146.83															7,342	11,012	14,683	18,354	22,025	29,366	36,708		
	3.50		144.28															7,214	10,821	14,428	18,035	21,642	28,856	36,070		
	4.00		141.33															7,067	10,600	14,133	17,667	21,200	28,267	35,333		

With over a century of manufacturing experience, consistent quality delivered on time is our guarantee. Being a 100% employee-owned company enhances the motivation of every JIT employee. Every employee understands their unique vital role toward earning and retaining long term customers.

JIT Cylinders is an employee owned company that does not make decisions based on stockholder value. We make decisions based on what our customer's value. Our goal is not to simply retain customers, we strive to continuously earn our customers by exceeding their expectations in terms of value, service, quality and delivery. Each day we compete for long term customers and are succeeding by nurturing a corporate culture that encourages and motivates our:

- *customer service managers to not answer phones, but service customers*
- *machinists to not 'cut chips', but deliver on-time quality*
- *engineers to not design, but innovate market driven products*
- *sales managers to not sell, but offer economical best practice solutions*

Our goal at JIT Cylinders is to achieve best-practice leadership in all processes. From our paperless manufacturing floor to our instant 24 hour support, we at JIT Cylinders are in business to serve customers and subscribe to the belief that our success will only follow the success of our customers.

Employee participation in quality-oriented teams also contribute to our quality manufacturing. Teams meet regularly to discuss better, faster, leaner and more economical ways to produce products and streamline manufacturing and sales operations. Our customers benefit from an improved product selection that is manufactured more efficiently.

Product quality is further enhanced by our continuing investment in capital equipment. Substantial expenditures have been made for flexible unmanned machining centers, computers on the manufacturing floor, CNC and NC machining centers, advanced material handling equipment, and testing stands.

The combination of dedicated, motivated and skilled employees coupled with state-of-the-art automated equipment and ample manufacturing capacity, results in a competitively priced, high-quality cylinder delivered on-time to customers worldwide.

Leadership in Innovation Unequaled Integrity of Design

In keeping pace with tomorrow, JIT Cylinders Research and Development Division believes that distinguishing itself through innovation is an essential factor for continued success. The objective of each project strives to exceed current and future application requirements.

Substantial investments are made to strengthen JIT Cylinders high-technology systems capabilities. Key initiatives are focused toward combining electronic controls, and new structural materials with environmental friendly mediums to improve productivity, energy savings, operator efficiency and comfort.

A commitment to quality engineering, research, and product development remains our principal focus.

"At JIT (Just-In-Time) Cylinders,

we supply

cylinder solutions for today and tomorrow's industrial applications. Being 100% employee owned

we work

as a unified team to exceed our customers' requirements. Through this motivational approach,

we deliver

innovative and responsive cylinder application solutions. At the same time,

we support

your engineering, design and manufacturing teams. Though this approach

we build

our leadership and strengthen our business to ensure

we create

long term partnerships."