



Dyadic

Mechatronics Cylinder



brought to you by

mirai intertechnologies

www.miraiintertech.com

D1209M



The versatile Mechatronics Cylinder series developed by Dyadic Systems is now available from \$340. (cable sold separately)

This servo actuator system is unique in that the motor, encoder, drive and the program memory are one integral package. Dyadic has developed the linear actuator drive mechanism such that the screw and nut are optimized for high accuracy, long life and high performance. This blend of low-cost and high performance could only have been realized by the advanced technology of Dyadic Systems.

These new product concepts give engineers a wider range of options to **eliminate over-design.**

Product Specifications Overview

Group		Rod style				
Model		SCN5-010	SCN6-020	SCN6-040	SCN6-050	SCN6-060
Type		Standard model	20kgf model	40kgf model	50kgf model	60kgf model
		Aluminum body				
		Built-in Amp.		External amplifier		
Priced From		US\$340	US\$465	US\$595	US\$500	US\$615
Page Reference		4	5	5	5	5
Stroke (mm)		50~300	50~300	50~300	50~300	50~300
Max. Thrust (in N)		100	200	400	500	650
(in Kgf)		10.2	20.4	40.8	51.0	66.3
Push mode max. (in N)		70	140	280	350	450
Thrust (in Kgf)		7.1	14.2	28.5	35.5	45.9
Max. Speed (mm/s)		400	200	200	100	100
* Typ. Data						
Repeatability (mm)		± 0.02 (Repeatable positioning accuracy for short time) * Notes 1, 2				
Backlash (mm)		0.3				
Radial Load Capacity		5~15 N	10~30 N	10~30 N	12~75 N	12~75 N
Rod		Ø15, M10 SS		Ø22 M14 Pitch 1.5 (303SS)		
Program Capacity		16 motions with programmable acceleration, velocity, position, and more (see "Functions" below).				
Power Supply		DC24V ± 10%				
Current		Max. 2.0 Amps	Drive Power max. 3.0 Amps, Control power max. 0.2A			
Life		Seals - 6 months, or 2,500 km run (Dust Proof Model Only)				
Others		3 years after delivery or 10,000 km operation when applied within published specs				
Parallel Input		Names DC24V type DI/DO Interface (Connector PIO), Position number (4bit binary: PC1,PC2,PC4,PC8)				
Current		Start (CSTR), Axis Movement Interlock (ILK)				
Parallel Output		Names Position complete(PFIN/INP), Homed signal(ZFIN), Zone signal(ZONE), Alarm (ALM),				
Current		24VDC Digital I/O Interface, PNP Standard (NPN Available)				
Serial Signal		- Completed Position Number (4bit binary: PM1,PM2,PM4,PM8),				
Protection function		Max. 10mA / port				
Temp., Humidity		RS-485 (protocol freely available): +5V, 5G, S+, S-				
Vibration		Over speed, Main power over voltage, Voltage fault, Overload, Sensor fault, Servo fault, Encoder wire disconnected				
Protection		Operating Temp.: 0 ~ 40°C, Storage Temp.: -20 ~ 60°C, Operating/Storage Humidity: Less than 90% RH, Non-condensing				
Weight (kgs)		1.2~1.4	1.6~3.1	1.9~3.4	1.9~3.4	1.9~3.4
Functions		Standard models: IP-40 equivalent, W (oil splash proof) models: IP-54 equivalent				
		- Positioning with speed, Accele.	- Stroke Limit end set	- Push Force Mode		
		- Home Direction Set	- Zone Signal output	- Servo Gain Adjust		
		- Incremental movement	- Complete signal width set	- Suitable Auto Max. Accel.		

** Specs to be subject to change without notice.

Note 2: Repeatability data is positioning from one direction with homing sequence each time.

Note 3: Homing stopper at both ends are urethan rubber (Shore hardness 90) and its aging deformation may be 0.05 - 0.07mm in couple of years, therefore we recommend the users to adjust the data for long run actuator repeatability for the critical applications.

Product Specifications Overview

Group	Rodless type				
Model	SCLL5-010	SCLG5-010	SCLG6-020 / 30	SCLT4-015 / 030	SCLT6-025 / 050
Type	10kgf model	10kgf & LM guide Acme screw+Bronze polymer nut Built-in & External amplifier	20/30kgf & LM guide External amplifier	15/30kgf & LM guide Ball screw Built-in & External amp.	25/50kgf & LM guide Ball screw External amplifier
Priced From	US\$700	US\$890	US\$945	US\$1,010	US\$1,165
Page Reference	6	6	7	8	8
Stroke (mm)	50~300	50~300	300~1,000	50~500	50~700
Max. Thrust (in N) (in Kgf)	50 5	100 10.2	200 / 300 20.4 / 30.6	150 / 300 15 / 30	250 / 500 25 / 50
Push mode max. (in N) Thrust (in Kgf)	30 3	70 7	140 / 280 14.2 / 28.6	105 / 210 10.5 / 21	175 / 350 17.5 / 35
Max. Speed (mm/s)	300	300	300	700 / 400	350
* Typ. Data					
Repeatability (mm)	± 0.02 (Repeatable accuracy for short time) * Notes 1, 2			± 0.02	
Backlash (mm)	0.3			0.1	
Max. Load wt (kgs)	5	10	20	5 / 10	16/30
Max. vertical load (kg)	2.5	2.5	10 / 20	1.5 / 2.5	4 / 6
Overhang (mm) * note 3	100 or shorter	150 or shorter	150 or shorter	100 or shorter	100 or shorter
Guide	Slide block	External LM guide	Internal LM guide	Internal LM guide	Internal LM guide
Program Capacity	16 motions, each with acceleration, velocity, position, and more (see "Functions" below).				
Power Supply	DC24V ± 10%				
Life	Current	Drive Power max. 3.0 Amps, Control power max. 0.2A			
	Seals	6 months, or 2,500 km run (Dust Proof Model Only)			
	Others	3 years after delivery or 10,000 km operation when applied within published specs			
I/O	Parallel Input	Names DC24V type DI/DO Interface (Connector PIO), Position number (4bit binary: PC1,PC2,PC4,PC8) Start (CSTR), Axis Movement Interlock (ILK)			
	Parallel Output	Current Max. 4mA / port Names Position complete(PFIN/INP), Homed signal(ZFIN), Zone signal(ZONE), Alarm (ALM), 24VDC Digital I/O Interface, PNP Standard (NPN Available) Completed Position Number (4bit binary: PM1,PM2,PM4,PM8: N/A for built-in models).			
	Serial Signal	Current Max. 10mA / port RS-485 (protocol freely available): +5V, 5G, S+, S-			
Protection function	Over speed, Main power over voltage, Voltage fault, Overload, Sensor fault, Servo fault, Encoder wire disconnected				
Ambience	Temp., Humidity	Operating Temp.: 0 ~ 40°C, Storage Temp.: -20 ~ 60°C, Operating/Storage Humidity: Less than 90% RH. Non-condensing			
	Vibration	2.5G / 10G (2 times)			
	Protection	IP-40 equivalent	IP-20 equivalent	IP-40 equivalent	
Weight (kgs)	1.0~1.8	1.3~2.3	2.7~10.7	1.42~2.4	2.7~5.4
Functions	<ul style="list-style-type: none"> - Positioning with speed, Accele. - Home Direction Set - Incremental movement - Stroke Limit end set - Zone Signal output - Complete signal width set - Push Force Mode - Servo Gain Adjust - Suitable Auto Max. Accel. 				

Other products

RSA Servo motor
Please see page 10



CTA-23 Teach Pendant
Program position data & Parameters



PC-CTC Tool
Program position data/Parameters, sequence data and
motor application parameters by PC

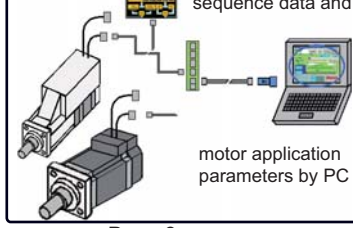

CTC-33 PLC Pendant
Program position data & sequence data



CTC-67 PLC Board
Program sequence data by PC operation

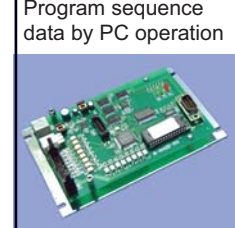

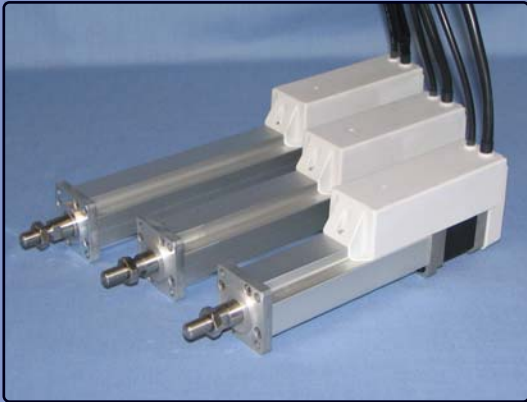

The SCN5 model Mechatronics Cylinders were developed in response to popular demand for a compact, affordable servo linear actuator. The cost of SCN5 actuators is roughly equivalent to that of air cylinders with accessories such as FRL, flow controls, reed switches, valves, etc.

With speed up to 400mm/s and stroke up to 300mm, SCN5 actuators are suited to a wide variety of applications. Different speeds and positions can be programmed as necessary, and it is also possible to control the force applied to the workpiece!

SCN5 actuators have extruded aluminum bodies and are assembled using socket-head machine screws to provide the toughness required in industrial environments.

Specifications

Models	SCN5-010-050AS03	SCN5-010-100AS03	SCN5-010-150AS03	SCN5-010-200AS03	SCN5-010-250AS03	SCN5-010-300AS03
Stroke (mm)	50	100	150	200	250	300
Max. Thrust	100 (N) / 10.2 (Kgf)					
Push force mode (N)	70					
Max. Thrust (kgf)	7.1					
Max. Speed (mm/s) - Typ.	400					
Radial Load Capacity (N)	15	10	5	4	3	2.5
Rod Diameter (mm)	Ø15					
Rod Tip Thread	M10 Pitch 1.25 (303SS)					
Weight (kg)	1.1	1.2	1.4	1.6	1.8	2.0

Note : Max vertical load is the same as the maximum force in push mode.
12 VDC Operation also permitted - Please contact Mirai for specs.

Speed-Thrust Curve

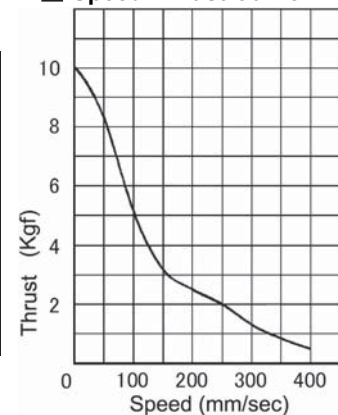

(Note) Vertical thrust is 7 kgf Max.

Dimensions (in mm)

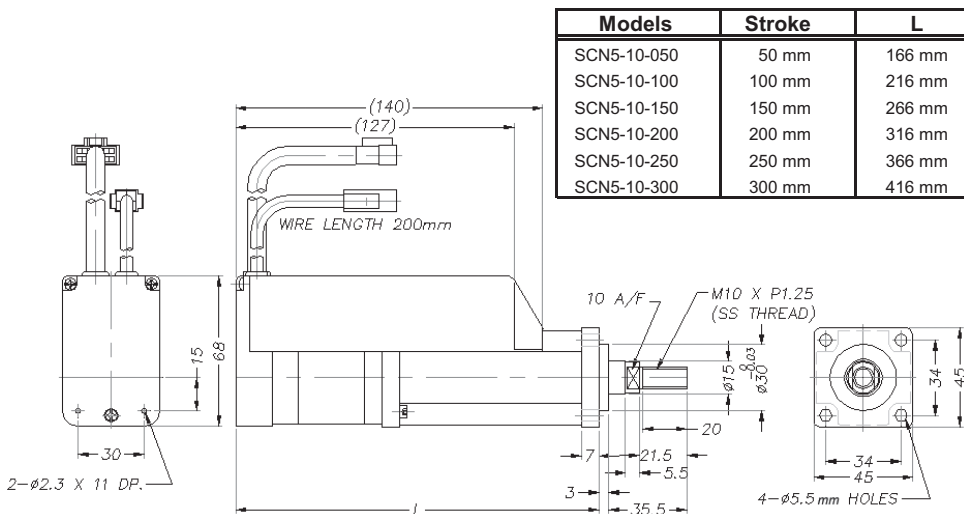

Accessories



Parallel Cables (power & I/O)

RP9100-030:
3m for SCN5 (\$48)

RP9120-030:
3m for other M.C. (\$59)



Thruster

- Simple thruster guides available
- Call to discuss your application



Brackets

FT001: \$20
- For SCN5

FT002: \$25
- For SCN6

Conversion Quick Reference

Type	Conversion	Multiplier	Reference Example
Force	N -> lbf	0.225	100 N = 22.5 lbf
Force	kgf -> lbf	2.2	10.2 kgf = 22.5 lbf
Torque	Nm -> in-lbf	8.85	5 Nm = 44.3 in-lbs
Inertia	kg-m ² -> oz-in ²	54678	0.269x10 ⁻⁴ kg-m ² = 1.47 oz-in ²
Inertia	kg-m ² -> oz-in-s ²	141.6	0.269x10 ⁻⁴ kg-m ² = 0.003809 oz-in-s ²
Distance	mm -> inch	0.03937	100mm = 3.937"

OTHER ACCESSORIES
We can help you with the following:

- Mounting plates
- Rod eyes and Clevises
- Thread Adapters
- Rod Couplers
- Pinch Rollers
- Others - just ask!

FEATURES

Unit includes:

- closed loop servo motor, external servo amplifier and control
- linear actuation mechanism with Aluminum extrusion housing
- table and slider mounting slots with nuts
- SCLG5 type: High rigidity model to build Gantry and Cantilever systems

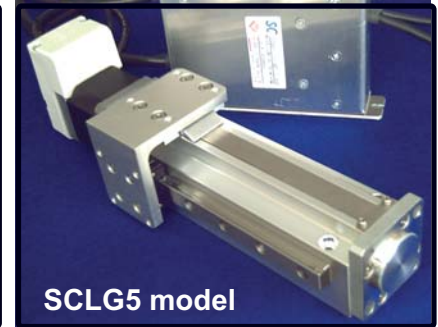
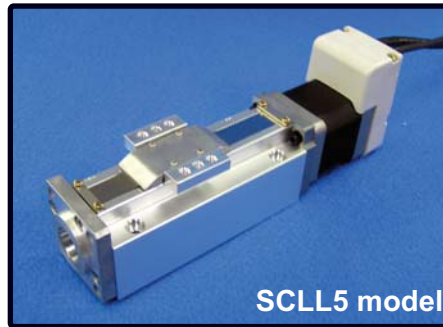

Specifications

MODEL	SCLL5-010-050	SCLL5-010-100	SCLL5-010-150	SCLL5-010-200	SCLL5-010-300	SCLG5-010-050	SCLG5-010-100	SCLG5-010-150	SCLG5-010-200	SCLG5-010-300
Stroke (mm)	50	100	150	200	300	50	100	150	200	300
Max. Thrust (N) / (kgf)	50 / 5					100 / 10.2				
Push mode max. Thrust (N)/(kgf)	30 / 3					70 / 7.1				
Max. Speed (mm/s) * note 1	300					300				
Max. Load weight (kgs)	5 (Horizontal)					10 (Horizontal)				
Max. vertical load (kgs)	2.5					2.5				
Max. axial thrust at power ON (N)	10					25				
Load moment (N-m) (Kgf-cm)	Mp=0.5 / 5.1, My=0.5 / 5.1, Mr=2 / 20.4 (* note 2)					Mp=1.5 / 15, My=1.5 / 15, Mr=5 / 51 (* note 2)				
Overhang length (mm) * note 3	100 or shorter					150 or shorter				

Notes: (*1) Typical data, (*2) This is a load that the wt (m kg) is generated by the overhang (L m) from the arrior slider.



(The calculation of the load moement (kgf-cm) is: m (kg) x L (cm) < Mp, My, Mr)

The actual moment will be combinations of those moments (Mp, Py, Mr).

Notes: (*3) This is the acceptable over hand length from the slider carriage.

Dimensions of SCLL5 model

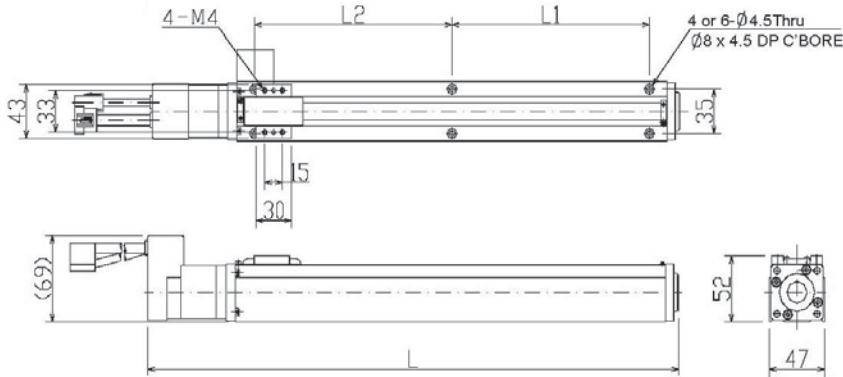

Models	ST	L	L1	L2
-050-AB	50 mm	201	85	
-100-AB	100 mm	251	135	
-150-AB	150 mm	301	185	
-200-AB	200 mm	351	117.5	117.5
-300-AB	300 mm	451	167.5	167.5

Note 1:
There are 6 mounting places for over 200mm stroke actuators

Dimensions of SCLG5 model

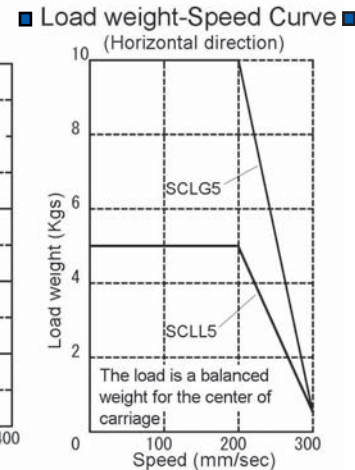
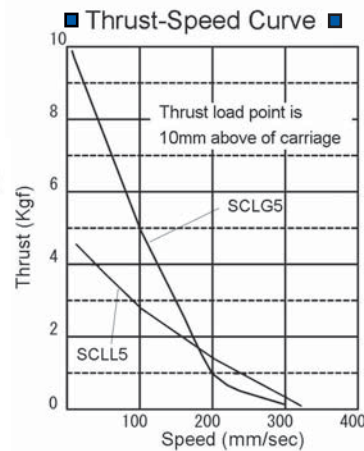
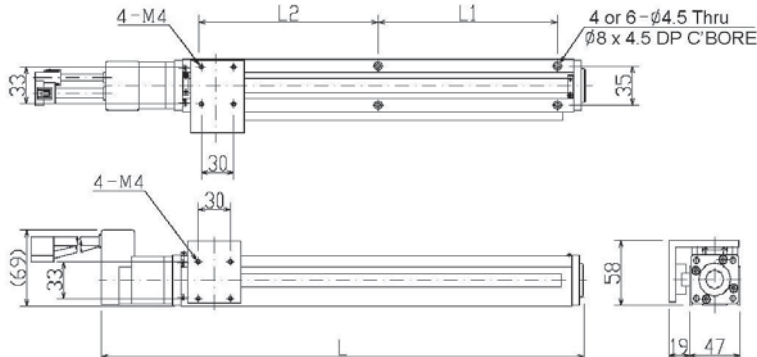

Load moment-Speed Curve

(Horizontal direction)

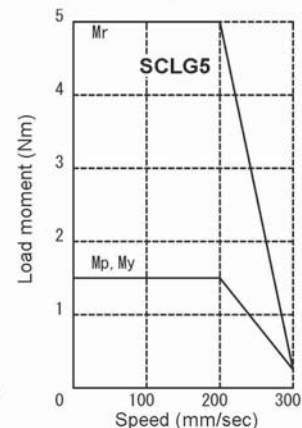
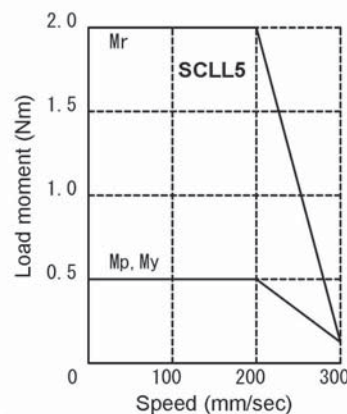

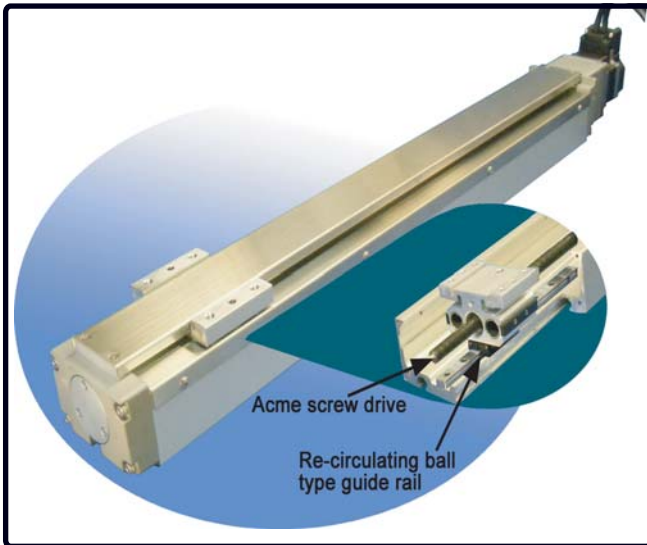

Thrust-Speed Curve

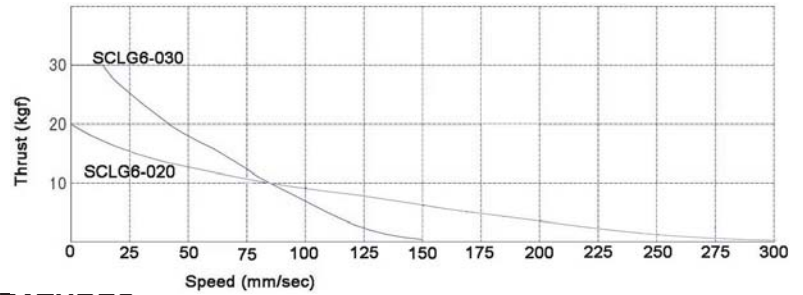

FEATURES

Unit includes:

- closed loop servo motor, external servo amplifier and control
- linear actuation mechanism with Aluminum extrusion housing
- Re-circulating ball type linear guide rail for heavier load
- positioning table and slider mounting slots with nuts
- exact replacement for SCLL6
- positioning table and slider mounting slots with nuts

Specifications

MODEL	SCLG6-020- XXX -AB							SCLG6-030- XXX -AB													
	300	400	500	600	700	800	1000	300	400	500	600	700	800	1000							
Stroke (mm)	300	400	500	600	700	800	1000	300	400	500	600	700	800	1000							
Max. Thrust (N)/(kgf)	200 / 20.4							300 / 30.6													
Push mode max. Thrust (N)/(kgf)	140 / 14.2							280 / 28.6													
Max. Speed (mm/s) * Typ. Data	300			280				220		150			150		140			110		75	
Max. Load weight (kgf)	20							20													
Max. vertical load (kgf)	10							20													
Load moment (N-m / kg-fcm)	Mp= 6 / 60, My= 6/60, Mr= 10 /100																				
Max. axial thrust at power ON (N)	25																				
Overhang length (mm)	150 or shorter																				
Actuator weight (kg)	3.7	4.7	5.7	6.7	7.7	8.7	10.7	3.7	4.7	5.7	6.7	7.7	8.7	10.7							
Servo amplifier weight (kg)	0.5																				

Dimensions

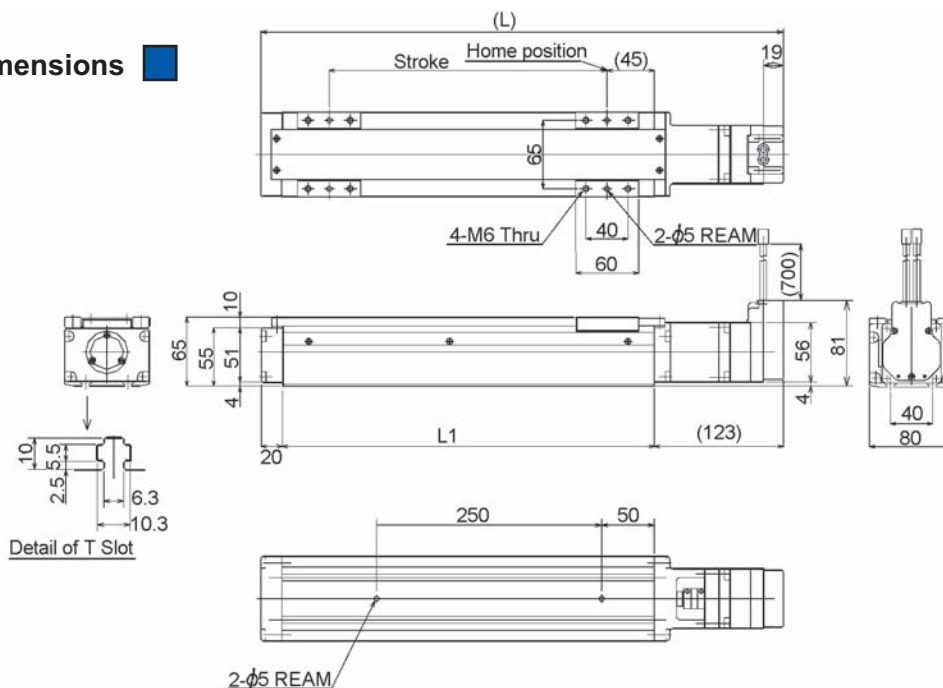

Quantity of M6 nut included for T slot:

Strokes	Quantity
200mm ~ 300mm	4 pcs
400mm ~ 700mm	6 pcs
800mm	8 pcs
900mm ~ 1000mm	10 pcs

MODEL	Stroke	L	L1
SCLG6-020/030-200	200	433	290
SCLG6-020/030-300	300	533	390
SCLG6-020/030-400	400	633	490
SCLG6-020/030-500	500	733	590
SCLG6-020/030-600	600	833	690
SCLG6-020/030-700	700	933	790
SCLG6-020/030-800	800	1033	890
SCLG6-020/030-900	900	1133	990
SCLG6-020/030-A00	1,000	1233	1090

(Unit in mm)

FEATURES

- closed loop servo motor, built-in/external servo amplifier and control
- rodless actuator with recirculating ball screw and profile rail.
- actuator can be mounted from above or below.
- SCLT4 has built in servo amplifier for easy installation.

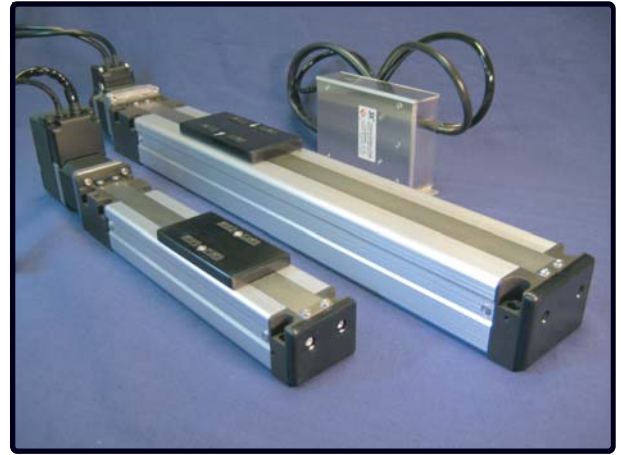
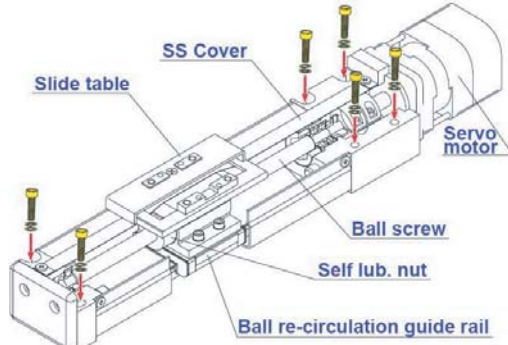

Specifications

MODEL	SCLT4-015 -XXX AS	SCLT4-030 -XXX AS	SCLT6-025 -XXX AB	SCLT6-050 -XXX AB
Amplifier	Built-in to actuator		External	
Stroke (mm)	50 / 100 / 150 / 200 / 300 / 400 / 500		50 / 100 / 150 / 200 / 300 / 400 / 500 / 600 / 700	
Max. Hor Load weight (kg)	5	10	16	30
Max. Thrust (N) / (kgf)	150 / 15	300 / 30	250 / 25	500 / 50
Push mode max. Thrust (N)/(kgf)	105 / 10.5	210 / 21	175 / 17.5	350 / 35
Ball screw lead (mm)	12	6	12	6
Max. Speed (mm/s) * note 1	700 (680mm/s for 500mm stroke)	400 (340mm/s for 500mm stroke)	600 (500mm/s for 700mm stroke)	350 (600mm: 340mm/s) (700mm: 250mm/s)
Repeatability (mm)	± 0.02	± 0.02	± 0.02	± 0.02
Backlash (mm)	0.1	0.1	0.1	0.1
Max. vertical load (kg)	1.5	2.5	4	6
Max. axial thrust at power ON (N)	15	25	40	60
Load moment (Nm / kgf-cm)	Mp=12 / 120, My=12 / 120, Mr=31 / 310		Mp=25.7 / 257, My=25.7 / 257, Mr=58 / 580	
Overhang length (mm) * note 2	100 or less			
Weight (kg)	1.42/1.53/1.64/1.74/1.96/2.18/2.4		2.7 / 2.9 / 3.1 / 3.3 / 3.7 / 4.1 / 4.5 / 5.0 / 5.4	

Notes: (*1) Typical data



(The calculation of the load moement (kgf-cm) is: m (kg) x L (cm) < Mp, My, Mr)

The actual moment will be combinations of those moments (Mp, Py, Mr).

Notes: (*2) This is the acceptable over hand length from the slider carriage.

Thrust-Speed Curve

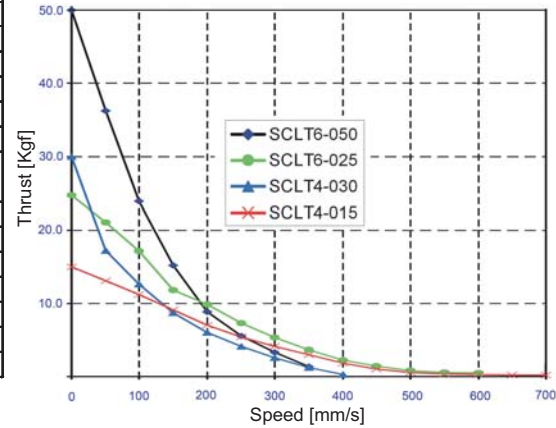

Dimensions

SCLT4 Model

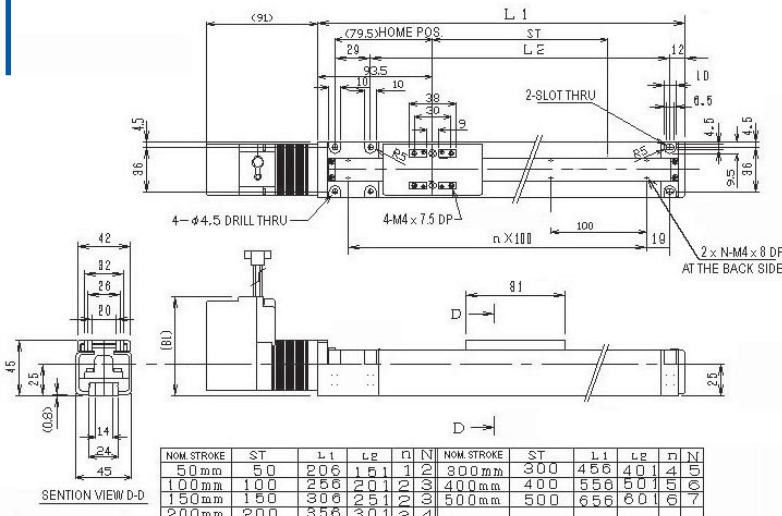

SCLT6 Model

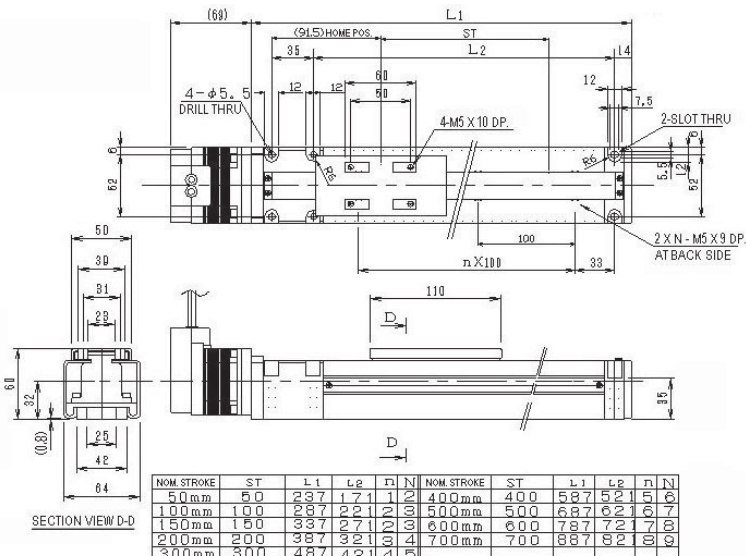

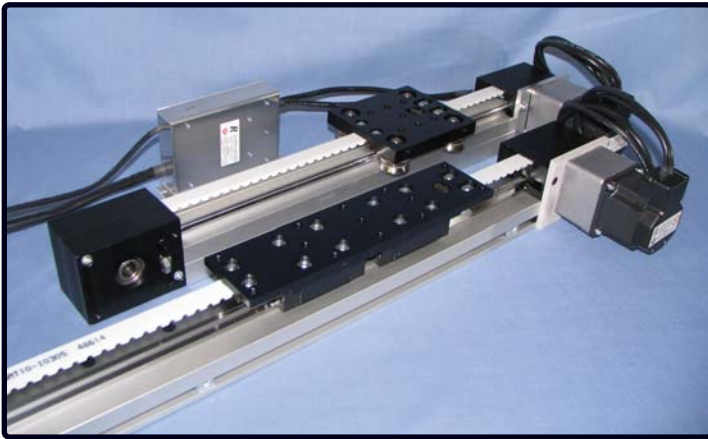

FEATURES

Unit includes:

- Using Dyadic closed loop geared or standard servo motor
- external servo amplifier and control
- Timing belt linear actuation mechanism
- Aluminum extrusion housing
- positioning table and slider mounting slots with nuts

Mechanical Specifications

MODEL	ML-AA-BBBB-SGR15	ML-AA-BBBB-SGR15D	ML-AA-BBBB-G20	ML-AA-BBBB-G20D
Stroke (mm) *	100 ~ 2850	100 ~ 2770	100 ~ 5850	100 ~ 5770
Stroke increment (mm)	100	100	100	100
Max. Load weight (kg)	25	50	360	720
Load moment (Nm)	Mp=10, My=7, Mr=13	Mp=30, My=20, Mr=25	Mp=180, My=180, Mr=220	Mp=600, My=600, Mr=440
Actuator weight (kg)	3.6 + 0.2 / 100mm	3.9 + 0.2 / 100mm	3.6 + 0.43 / 100mm	3.9 + 0.43 / 100mm
Belt Type	16AT10			
Pulley teeth/revolution	18			
Pulley Diameter (mm)	55.5			
Travel per revolution (mm)	180			
Servo amplifier weight (kg)	0.5			
Ordering Codes	AA = MOTOR CODE, BBBB = STROKE LENGTH (mm)			

* Please ask about special considerations regarding actuators 2,000 mm and longer

Performance Specifications

Available Options:

- Bore & mount for your motor/ gearbox
- Transition plates for cartesian systems
- Bored idler for synchronizing shaft
- Cable management
- Other requirements? Just ask!

MOTOR CODES	G1	G2	P5	P10	P20	P50	P100
Max. Speed (mm/s) * Typ. Data	1744	872	2325	1162	581	232	116
Thrust @ 20% Max Speed (N)	46	92	45	91	172	430	859
Max. vertical load (kg)	5	9	5	9	17	43	86
Repeatability (mm)	0.1 mm	0.1 mm	0.1 mm	0.1 mm	0.1 mm	0.1 mm	0.1 mm
Backlash (mm)	~1.5 mm		0.15 mm	0.15 mm	0.15 mm	0.2 mm	0.2 mm

Dimensions

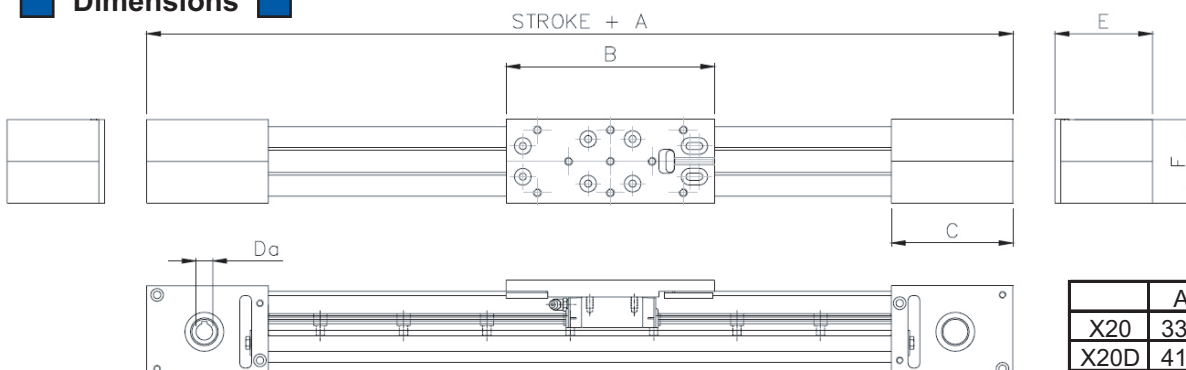

	A	B	C	E	F	M
X20	335	150	87.5	70	60	M6
X20D	415	250	87.5	70	60	M6



Speed-Torque Curves

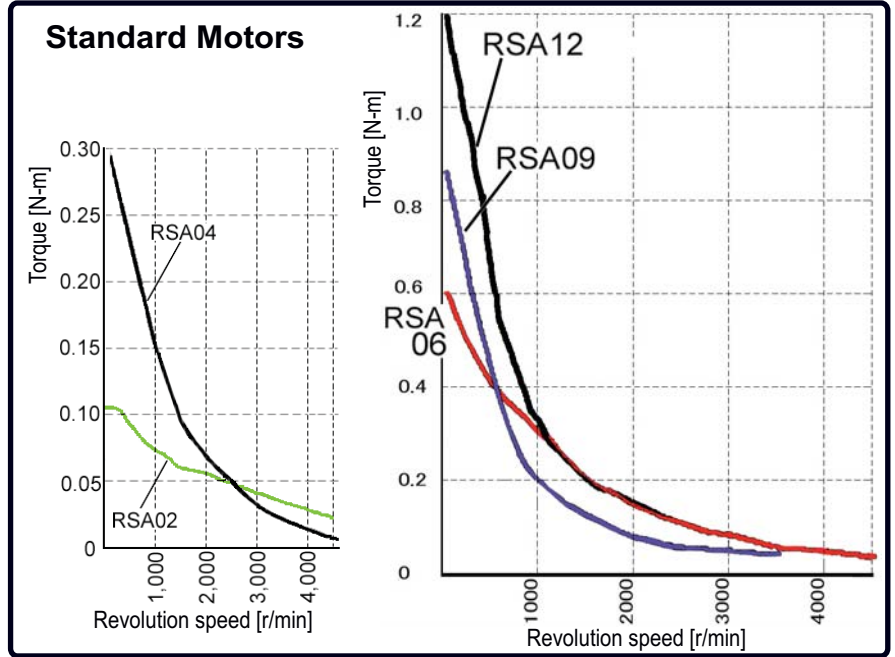

Features

- * No lost pulses
- * Self generation of pulses for stable motion
- * Controller designed to fully harness high potential of motor
- * Holds position with excellent stability and torque
- * High performance in its size
- * Stepper with servo amp. & controller

Specifications

Model	Standard Motor					Standard Gear Motor		Precision Gear Motor (RSA-)				
	RSA02	RSA04	RSA06	RSA09	RSA12	RSA06-G1	RSA06G2	02-G5-10	04-G5-06	06-G5-05	12-G5-05	
Motor Type	RMJ02	RMJ04	RMJ06	RMJ09	RMJ12	RMJ06-G1	RMJ06-G2	RMJ02-G5-10	RMJ04-G5-06	RMJ06-G5-05	RMJ12-G5-05	
Amplifier Type	RAD0211	RAD0111	RAD0311	RAD1311	RAD2311	RAD0311	RAD0311	RAD0211	RAD0111	RAD0311	RAD2311	
Output Power *Note 1	W	20	50	90	60	100	N/A					
Max. RPM	RPM	4,500	4,500	4,500	3,500	4,500	600	300	450	750	800	800
Max. Torque	N·m	0.11	0.3	0.6	0.9	1.2	1.5	2.5	0.8	1.4	2.6	4.8
Rotor Inertia	(x10 ⁻⁴ Kg·m ²)	0.018	0.076	0.115	0.188	0.269	0.14	0.14	0.018	0.078	0.135	0.289
Max. Friction Load	N·m	0.03	0.083	0.229	0.36	0.5	N/A					
Max. Unbalanced Load *Note 2	N·m	0.03	0.075	0.229	0.36	0.5	N/A					
Gear Reduction	grams	N/A					1/5	1/10	1/10	1/6	1/5.6	1/5.6
Motor Weight	grams	400	500	640	830	1,200	900	900	350	850	1,000	2,000
Incremental encoder		200 P/R (x 4 = 800 P/R)					1000 P/R (x 4)	2000 P/R (x 4)	2000 P/R (x 4)	1200 P/R (x 4)	1120 P/R (x 4)	1120 P/R (x 4)
Backlash		N/A					120	60	30	48	48	48
Thrust Load Capacity	N (kgf)	4.9 N (0.5 Kgf)	9.8 N (1 Kgf)	19.6 N (2 Kgf) or smaller			29.4 (3)	24.5 (2.5)	59 (6)	294 (15)	294 (15)	294 (15)
Radial Load Capacity	N (kgf)	19.6 N (2 Kgf) or smaller		49 N (5 Kgf) or smaller			49 (5)	49 (5)	118 (12)	294 (30)	294 (30)	294 (30)
Power Supply	Drive Power	24VDC+10% (2A Max)			DC24V ± 10% (3.0 Amps Max.)							
	Control Power	DC24V ± 10% (0.2 Amps Max.)										
Amplifier weight	grams	approx. 400										
Motor insulation classification		Class E										
Motor protection		IP-40 equivalent										
Program Capacity		16 position steps (incl. Position, speed, acceleration, torque control, etc.)										

Note 1: Reference only.

Note 2: In case of lower positioning current limit, this unbalance load will be lower as well. In case of the use for vertical axis,

Note 3: Max. power dissipation of Amplifier will be 15W.

Dimensions - Standard Motor

RSA06, 09 & 12 (NEMA 23 Model)

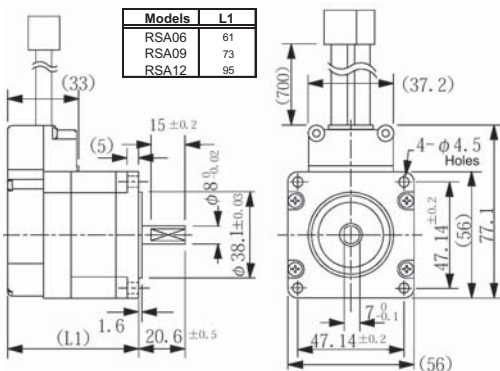

RSA04 (NEMA 17 Model)

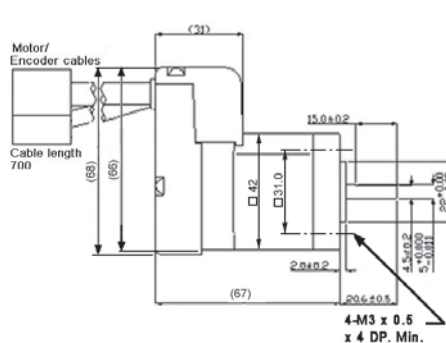

RSA02 (NEMA 12 Model)

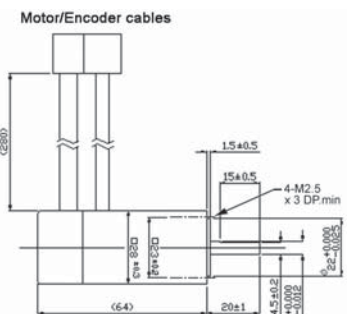

Position Data Programming Tool

Teach Pendant (CTA-23-EN-SET) Kit price US\$455

Features

- * Easy programming with jog handle
 - * Jog handle has choice of standard jog and fine jog
 - * Handle allows data input without jog movement if desired
 - * Visual indication of the programming procedure
 - * Complete control over all actuator capabilities
 - * Program one actuator at a time,
- for multi synchronized actuator motion programming tool, please consult Mirai.



Connection layout

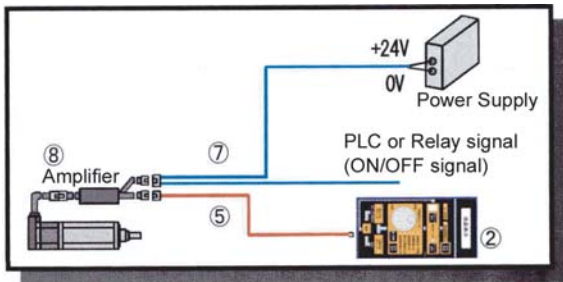

- Contents:
- * Teach pendant (CTA-23-EN)
 - * ADP cable (RP9050-010)

PC-CTC Tool Kit (TBVST-CTC-EN-SET) US\$275

Features:

- * Easy Window-based programming
- * Programming with jog and data entry
- * Down-load, Up-load functions
- * Actual movement result analysis function
- * Able to program position parameter/data and sequence program for CTC pendants
- * Contains all software in one package (TBVT, MVST, CTA-1EX and CTCTOOL)

Kit Contents:

- * Software disc for PC tool and CTC tool
- * RS232/485 converter ADP-1
- * Connector converter ADP-2
- * ADP cable
- * SIO cable

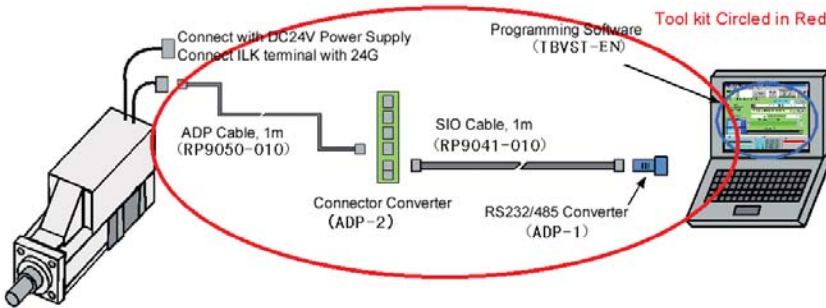
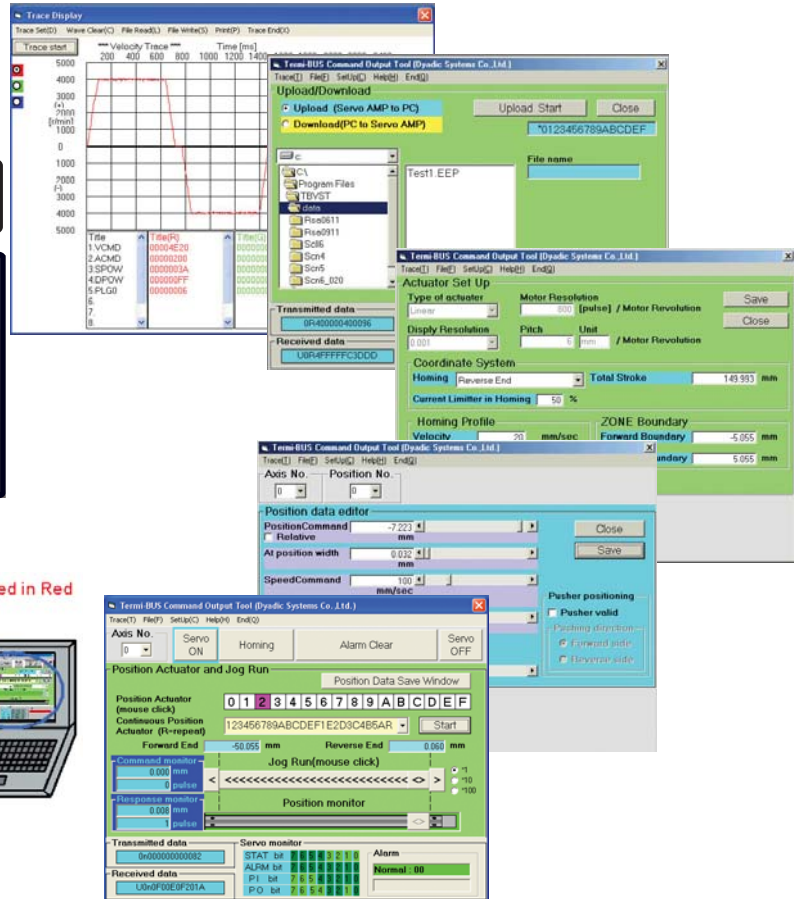

Accessories

PC-CTC Tool Parts



ADP-1: 232/485 adaptor



RP9050-010: ADP cable



RP9041-010: SIO Cable



ADP-2-4: Connector junction

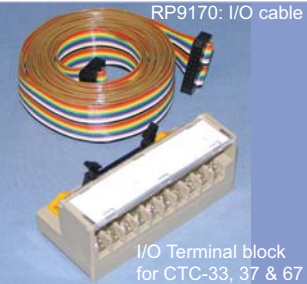

I/O Terminal block for CTC-33, 37 & 67

Sequence Data Programming Tool

PLC Pendant (CTC-33-EN-SET) Kit price US\$700

Features

- * Easy programming with jog handle
- * Jog handle has choice of standard jog and fine jog
- * Handle also allows data input without jog movement
- * Program position data and sequence with I/O and delay time (upto 41 steps)
- * 6 inputs/6 outputs for users
- * 8 actuators connectable
- * Control up to 5 axes per step
- * Panel/backplane mounting style
- * Visual indication of the programming procedure



① SIO Cable RP9041-XXX

- Contents:
- * PLC pendant (CTC-33-EN)
 - * ADP cable (RP9050-010)

Connection layout

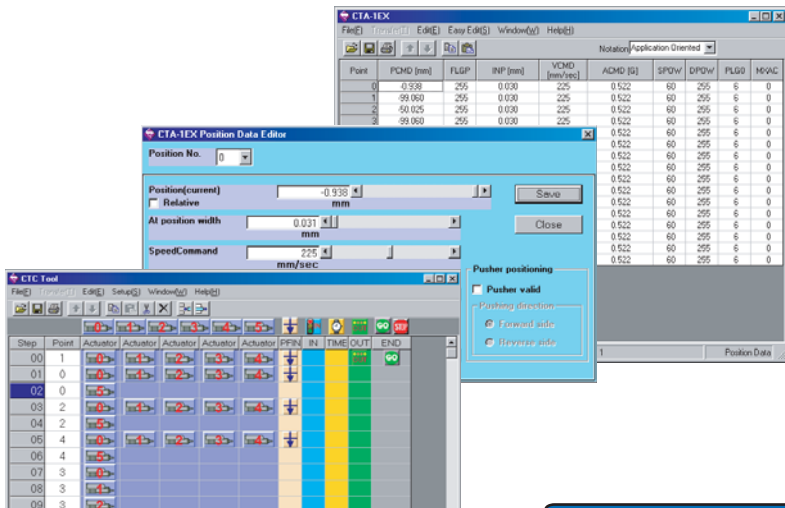
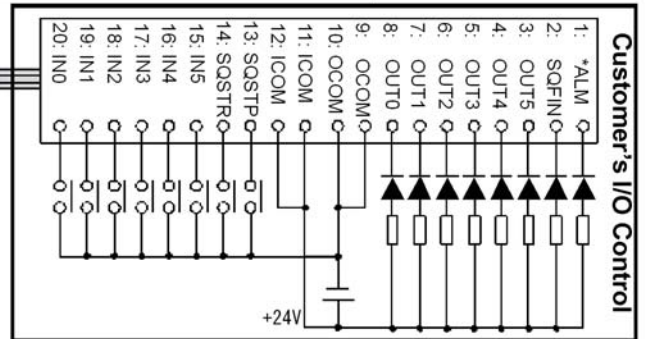
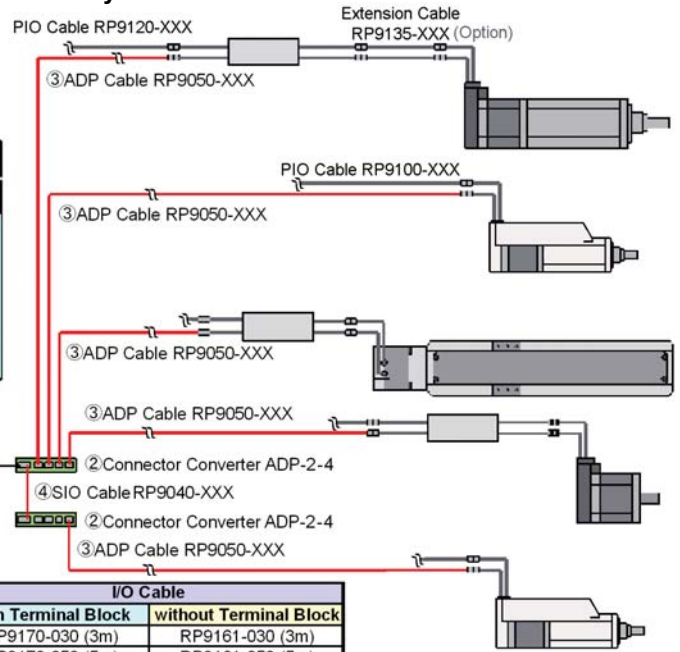

PLC Board (CTC-67-EN-SET) Kit price US\$395

Features :

- * Easy programming by CTCTOOL software
- * Program up to 100 steps, each with timers, I/O conditions, etc.
- * Connect up to 8 actuators
- * Control up to 5 axes per step
- * 6 inputs/6 outputs for users

Benefits :

- * Reduce I/O using pre-made cables
- * In complex systems the PLC programming can be simplified by allowing the CTC-67 to execute subroutines selected by the PLC.
- * For simple systems (lab scale, bench top), the CTC-67 can be the only controller. System elements can be easily controlled through the programmable I/O.
- * Debug mode allows the user to run the sequence one step at a time.
- * The time monitor function can ensure the sequence is complete in the required time.

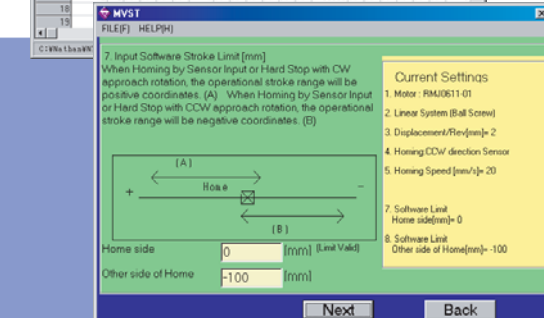

Application Examples : By using the Mechatronics Cylinder, flexible systems can be built easily without extra cost.

Guide rail width change

Guide width change

Palletizing/De-palletizing

Incremental motion of Mechatronics Cylinder will make palletizing system easier.

Tip for incremental motions

Incremental motions can be used to make flexible stroke motion as follows:

- Increment 1: 10mm
- Increment 2: 5mm

A: When executing 2, 1, 2 respectively

B: When executing 2, 1, 2 during first motion

Sensor position change

Sensor positions can be programmed. Line change over time will be reduced.

Welder vertical motion

Electrode motion and force can be controlled using push force mode

Filling Nozzle Positioning

Smooth nozzle movement can be programmed for smooth filling.

Avoid collision by Zone signals

Multi Axis motion control can avoid collision by using Zone signals.

Reciprocating pump

Pumps can be programmed with volume stroke, acceleration for smooth and high speed dispensing

Palletizing P&P

Increment function will make palletizing P&P system programming easier.

Fluorecent lamp clamping

Delicate objects such as light bulbs can be clamped using adjustable push force.

AGV operations

AGVs equipped with 24VDC power have used Dyadic products in the following applications:

- precise conveyor drive, moving a stopper for conveyed items,
- extending re-charge connector, changing work table height, and coupling carts together.

All products come with a low-power resting mode which allows for maximum battery life.

Bottle/Can conveyor guide

- For plastic bottle high pressure blower conveyor
- Height guide for can conveyor

Air blow line change over time will be much quicker.

Zone signal inspection

If the Mechatronics Cylinder is programmed with zone signal with parts size tolerance, parts size inspection can be done.

- Zone signal: ON => Good (in Tolerance)
- Zone signal: OFF => NG (out of Tol.)

Push force movement

Zone signal output

MEG Pick&Place Unit

PPU Model Overview



The low-cost PPU line is suited for a wide range of pick and place applications. Simple structure and mounting make it easy to design in and install. The PPU provides smooth cam motion at high speed with low cost. Center or Left carry, right carry or overhead carry options are available to suit your application.



Specifications of CAM Models

Models	Type	Center carry	Side carry	Linear guide	Model No.	Strokes (X x Z) mm	Application Range		Dynamic repeatability	Motor Power W	Homing sensor (Photo micro sensor)
							Load incl. fixtures (Kgs)	Cycle time (sec)			
Economy		O		O	X6092	80 x 20	0.9 0.3	1.4 1.0	+/- 0.015	25	Accessory
			O	O	X6072L						
			O	O	X6072R						
Standard		O		O	X6091	100 x 30	1.5 0.3	2.1 1.2	+/- 0.015	25	Accessory
			O	O	X6071L						
			O	O	X6071R						
	High rigidity		O	O	X6071WL						
	High rigidity		O	O	X6071WR						
	Over head		O	O	X6076WL						
			O	O	X6076WR						
			O	O	X6091S						
			O	O	X6071SL						
			O	O	X6071SR						
Semi Long			O	O	X6094	160 x 35	2.0 0.7	2.5 1.6	+/- 0.015	25	Accessory
			O	O	X6074L						
			O	O	X6074R						
			O	O	X6094S	160 x 50	2.0 0.5	2.7 1.6			
			O	O	X6074SL						
			O	O	X6074SR						
	High rigidity		O	O	X6076WSL						
High rigidity		O	O	X6076WSR							
Long		O			X6085	200 x 50	1.5 0.9	2.4 2.0	+/- 0.015	40	Accessory
Notes						* 1	* 8	* 2	* 3		

- * 1 : Stroke cannot be adjusted after customization.
- * 2 : Standard motor is the induction motor of Oriental motor.
- * 3 : Attached sensors are home photo micro sensor and a CAM sensor.
- * 8 : Top data is max. weight and the min. cycle time for the max. weight. Bottom data is min. cycle time with max. weight. Please check the cycle time and carriable weight graph.
- *** Specifications to be subject to change without notice.



Specifications of Stepper Drive Models

Models	Model No.	* 1 & 2 Strokes (X x Z) mm	Application		* 4 Dynamic repeatability	Motor Torque kgf-cm
			Load incl. fixtures (Kgs)	Cycle time (sec)		
Compact	X6303	30 x 10	0.2 0.1	0.6 0.4	+/- 0.025	8.3
	X6305	50 x 15	0.2 0.05	0.74 0.4		
	X6307	70 x 15	0.2 0.05	0.9 0.5		
Intelligent	KS8015	80 x 13	0.1 0.07	0.6 0.4	+/- 0.025	16.6
	KS12020	120 x 18	0.15 0.08	0.9 0.5		

- * 1 : X axis stroke cannot be adjusted.
- * 2 : Z axis stroke data is valid stroke. There are about 2mm more to the mechanical end.
- * 3 : Compact type has mech controller with photo sensor and dog as a standard.
- * 4 : Top data is max. weight and the min. cycle time for the max. weight. Bottom data is min. cycle time with max. weight. Please check the cycle time and carriable weight graph.
- *** Specifications to be subject to change without notice.

Internal mechanism example

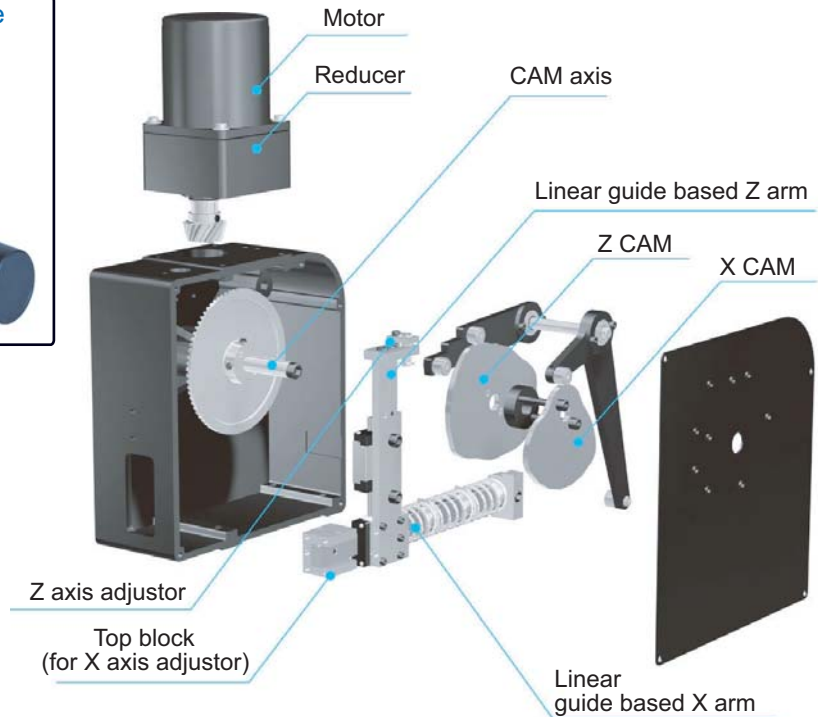



MDC Model: Low-Cost DC Linear Actuators



For applications which require high force or analog feedback, actuators from the MDC line may be the perfect fit. These actuators are simple to install and operate and able to go anywhere!

Specifications

Specification Summary - MDC Low-Cost DC Actuators			
Model	MDC3	MDC10	
Screw Type	Acme	Acme	Ball screw
Max Speed (mm/s)	55	40	65
Max Load (N)	800	7,000	
Stroke Range (mm)	50 - 300	84 - 612	
Potentiometer Option	Y	Y	
Hall Effect Option	Y	N	
Limit Switch Standard	Y	Y (Adjustable)	
Temp. Rating	-25 ~ 65°C	-25~65°C	
Duty Cycle	20%	25%	
Operating Voltage	12VDC or 24VDC		
Mounting	Clevis-Clevis		
Protection	IP-65		

FEATURES

- DC motor linear shaft motion actuator
- High force with analog feedback
- strokes from 50 - 612mm
- built-in limit switches
- clevis-clevis mounting
- Good environmental protection

Mirai Intertech also presents:

SANCI PIEZO FEEDER

Features:

- Driven by Piezo-Ceramic resonator
- Quiet vibration
- Repeatable digital feeding vibration
- Provide low amplitude & high freq. vibration
- No MAGNETIC EFFECT
- No HEAT generation
- Low power consumption-up to 70% power save
- Easy Frequency/Volume adjustment



Presented by:

Mirai Inter-Technologies Systems Ltd.



***** We present the meeting of technologies *****

30 Pollard St., Richmond Hill, Ontario Canada L4B 1C3
Tel:(905)763-9442, e-mail: sales@miraiintertech.com