



# COVAL

vacuum managers

mini-modules  
"ASC" compact vacuum pumps

# LEMAX



**AIR Saving Control**

# LEMAX series: compact

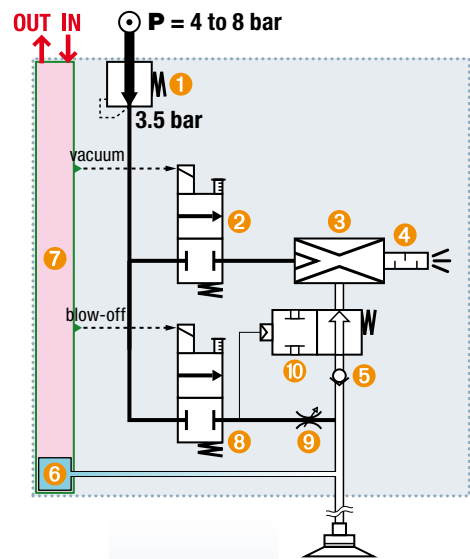
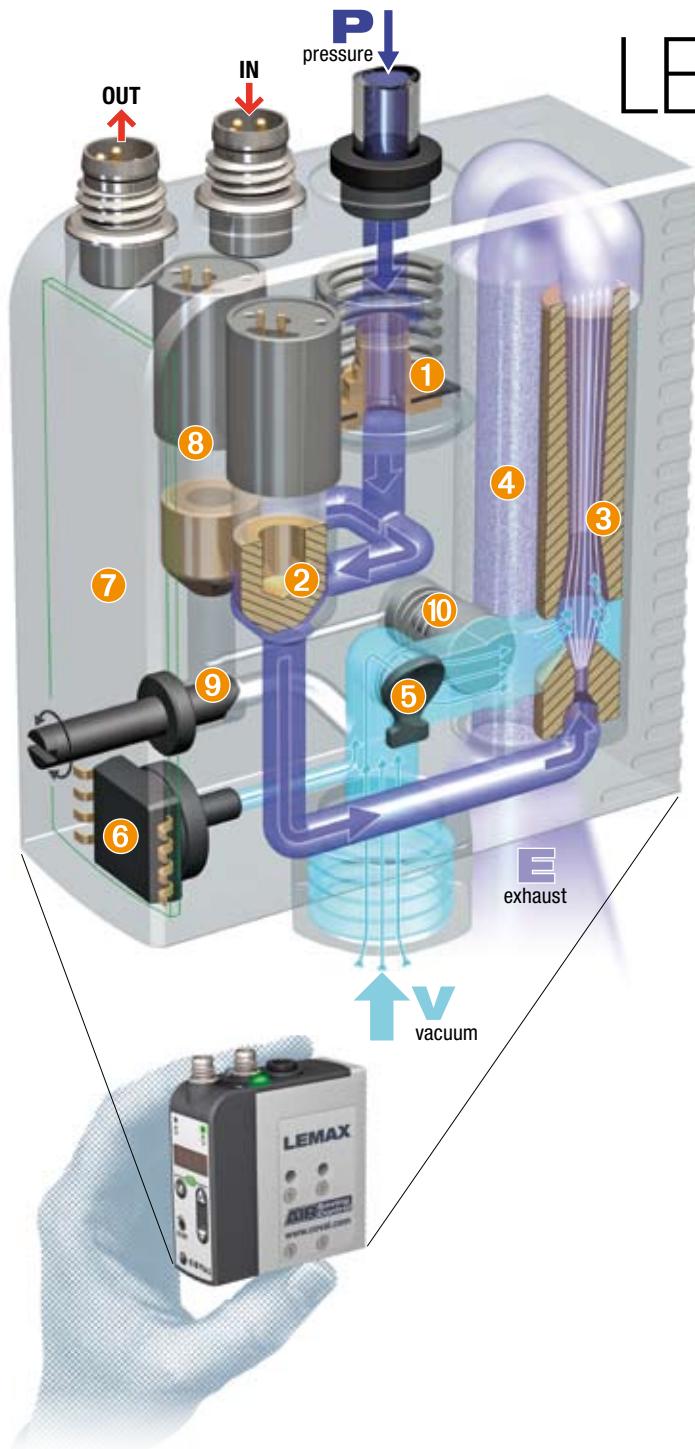

## INTEGRATED FUNCTIONS

- |                              |                             |
|------------------------------|-----------------------------|
| 1 3.5 bar pressure regulator | 6 Vacuum sensor             |
| 2 "Vacuum" solenoid valve    | 7 Integrated electronics    |
| 3 3.5 bar optimized venturi  | 8 "Blow-off" solenoid valve |
| 4 Optimized muffler          | 9 Blow-off flow regulator   |
| 5 Vacuum non-return valve    | 10 Isolation valve          |

## ADVANTAGES:

- **"ASC" process regulation:**
  - energy savings pay for investment in just a few months.
- **Integrated intelligence:**
  - continuous working follow-up.
- **Simplified use:**
  - plug & play, programmable automatic blow-off ...
- **Short response times:**
  - due to easy installation very close to vacuum pads.
- **Dust resistant:**
  - non clogable open silencer.
- **Silent technology:**
  - pump at rest most of the cycle.
- **Safety:**
  - product gripping is maintained even with power failure.

## Compact integration: The COVAL technique

The illustrations demonstrate the COVAL performance: all necessary functions are integrated into a complete and self governing mini-module, together with the electronics that permanently controls the "ASC" process.

**"ASC"** = **AIR Saving Control**

→ Once vacuum is established, no more air consumption to hold the product.

**CONCLUSION:** a major innovation, key to an up-to-date and rational practice of vacuum handling.

# integration + Air Saving Control (ASC)

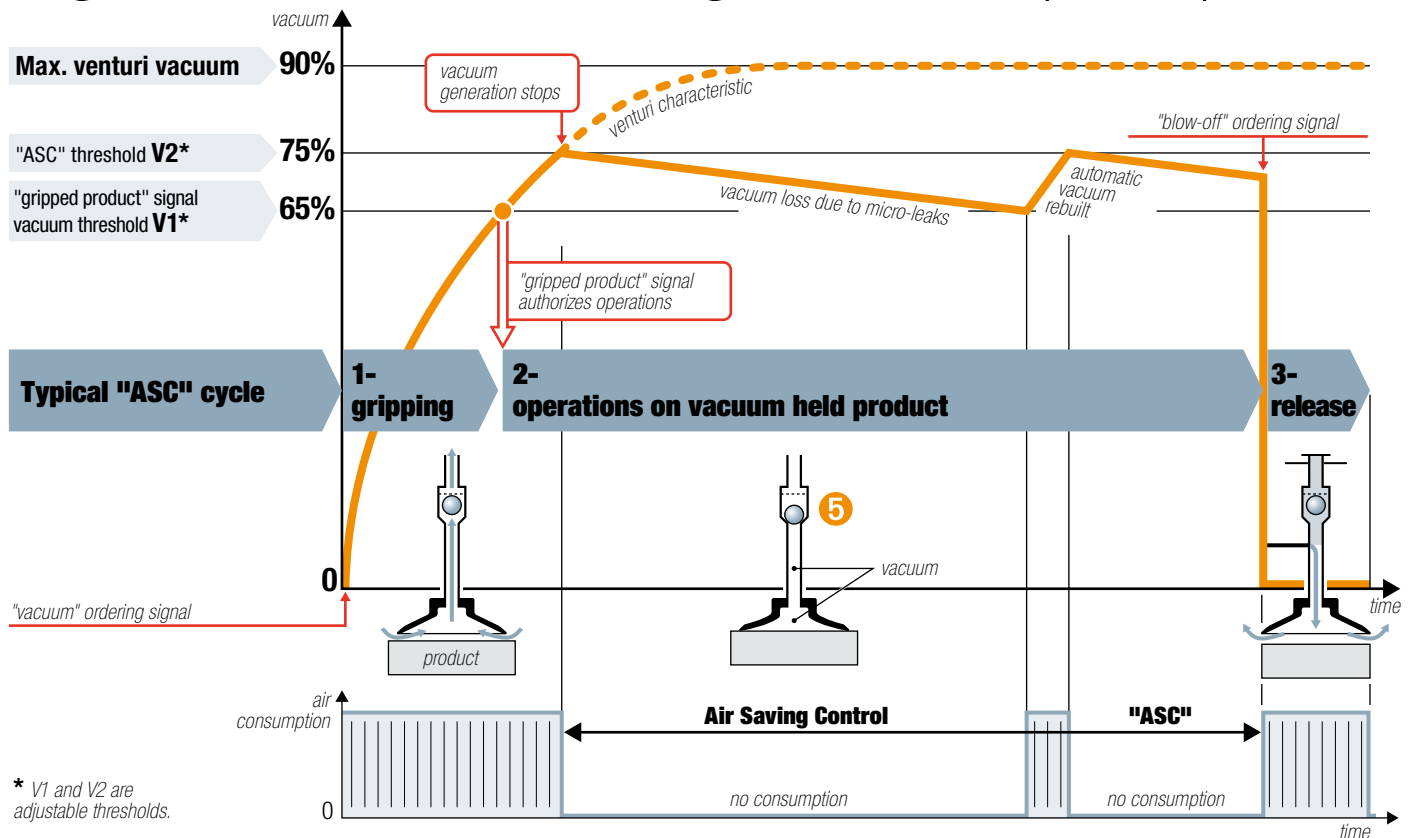

## The "Air Saving Control" cycle

As shown above, the LEMAX module automatically develops the ASC cycle, thus providing the maximum energy economy, by following the 3 steps.

### 1- Product gripping

The "vacuum" solenoid valve ② starts the cycle by feeding air pressure to venturi ③ that generates vacuum for product gripping → short time air consumption.

### 2- Operations on vacuum held product

The vacuum level is continuously measured by vacuum sensor ④. When vacuum reaches V1 threshold (65%), the "product gripped" signal is sent to authorize the operations (transfer, machining ...) on the product. When vacuum reaches V2 threshold (75%), solenoid valve ② cuts off the venturi supply → air consumption totally stops. The product is then held by the remaining vacuum kept by the closing of the vacuum non return valve ⑤.

Micro-leaks generally make vacuum level slowly drop down. Each time it reaches 65%, a short vacuum generation rebuilds the vacuum level up to 75%.

### 3- Product release

At the end of operations, release is ordered. "Blow-off" solenoid valve ⑥ sends an air jet that closes isolation valve ⑦ and blows-off the product for a fast release. Blow-off flow is adjustable through regulator ⑧.

**ASC automatically provides a 60 to 99% energy economy, depending on application: investment is paid for, in just a few months.**

## ASC: a must for competitiveness

Since ASC generates major energy economies, it is a key factor for production competitiveness. Two typical examples:

### 1- Gripping + transfer (nozzle ID 1.4 mm, emptying 0.2 l).

Phase	Duration	Air consumption		achieved economy
		without ASC	with ASC	
Gripping	0.28 s	0.4 NI	0.4 NI	75%
Transfer	1.20 s	1.8 NI	0	
Release	0.14 s	0.2 NI	0.2 NI	
		2.4 NI	0.6 NI	

### 2- Clamping + operations (nozzle ID 1.4 mm, emptying 0.4 l).

Phase	Duration	Air consumption		achieved economy
		without ASC	with ASC	
Clamping	0.55 s	0.8 NI	0.8 NI	99%
Operations	60 s	90 NI	0	
Release	0.14 s	0.2 NI	0.2 NI	
		91 NI	1.0 NI	

**AIR**Saving Control

**twin tech**<sup>TM</sup>  
Integration & Intelligence

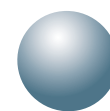

**COVAL**  
vacuum managers

# LEMAX series: integrated intelligence

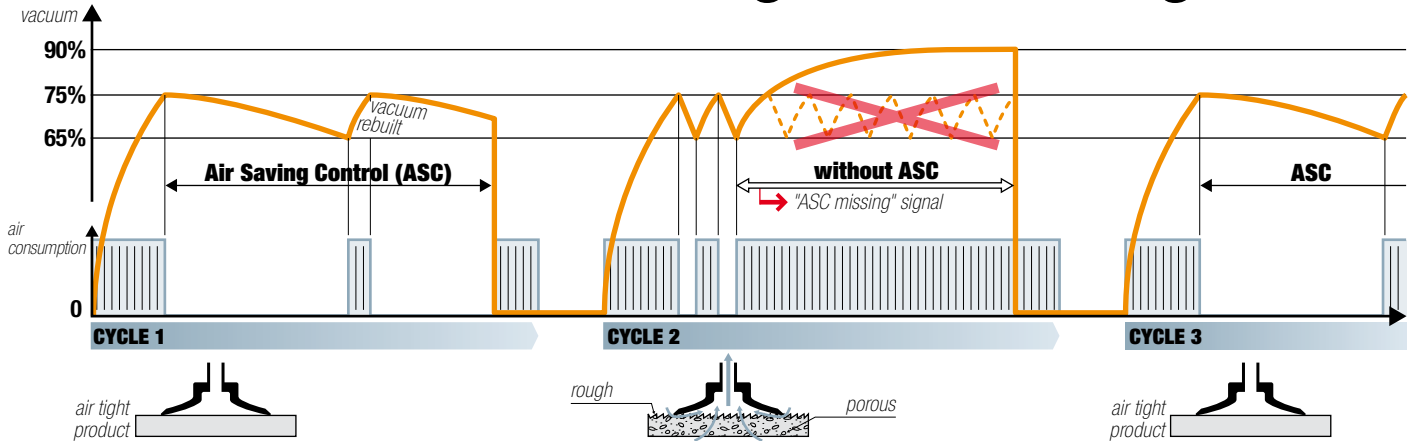

## Adaptation intelligence

The above example shows the LEMAX module adaptation capacities from one cycle to another:

### ■ CYCLE 1

The ASC regulation process starts automatically. Due to micro-leaks, vacuum rebuilds happen according to need.

### ■ CYCLE 2

If uncontrollable leaks arise (here due to a rough or porous product), vacuum rebuilds must compensate, thus generating fast vacuum cycling, i.e. excessive use that could wear out the module. The integrated intelligence detects the anomaly, ends the cycle without "ASC", and sends out the "ASC missing" signal.

### ■ CYCLE 3

If the next product is air tight, the ASC cycle is automatically restored and the "ASC missing" signal disappears.

The module integrated intelligence adapts the cycle to the type of product (air tight or not) and, on longer terms, will call for maintenance when leaks are the result of vacuum pads or circuit aging.

## ASC: a simple practice with no limits

Saving energy is now a major goal. With LEMAX, due to ASC, such saving is automatically obtained without changing the established practice.

### 1- Choice from a wide range (see p.7 and 9)

Stand-alone or island modules, specific signal or automatic blow-off, NO vacuum solenoid valve for product holding security.

### 2- No specific setting

The factory setting (V1=65% vac., V2=75% vac.) is convenient for most applications.

### 3- Production override

The production process carries on, possibly without ASC, if leak level is too high.

### 4- Guided maintenance

Clear display of the maintenance requirements in order to return to the ASC regulation.

## Communication intelligence

The LEMAX module integrated intelligence also controls the following communications:

### ■ Sent out signals

- "Gripped product" signal.
- "ASC missing" signal and, in complement, a blinking alert message onto the panel running display.

### ■ Display and dialogue

- Scrolling display for follow-up and diagnostic.
- Visual indicators: "vacuum", "blow-off", "gripped product" signal.
- Manual overrides: "vacuum", "blow-off".

### ■ Configurations

The keys and indicators shown below give access to:

- the language selection.
- the choice of blow-off type: controlled or auto 0 to 3s.
- The auxiliary output configuration → see page 10.

### ■ Settings

The LEMAX module is supplied pre-programmed according to the "factory" setting: V1=65% vac., V2=75% vac. However, for very specific applications, this setting may easily be changed as needed.

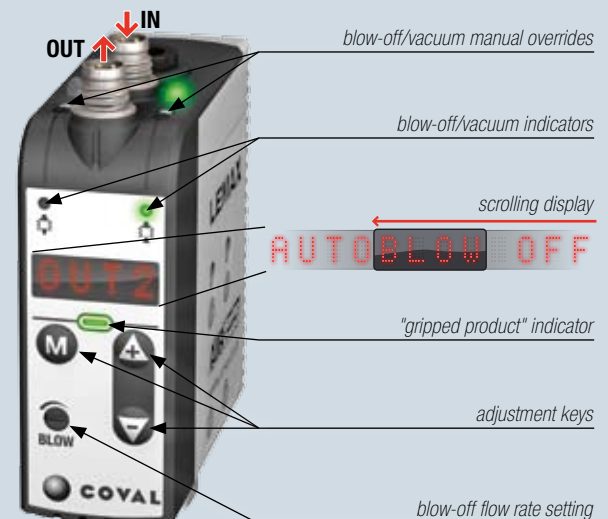

# Stand-alone and island modules

The LEMAX series offers 2 module shapes:

## 1- Stand-alone modules

The full answer to the most common application, where all vacuum pads are working according to the same sequence.

They are individually fixed, supplied and controlled. Their integrated 3.5bar pressure regulator allows a direct supply from the air pressure network, from 4 to 8 bar.

See p. 6 and 7 the part numbers, the connections and the fixings of stand-alone modules.

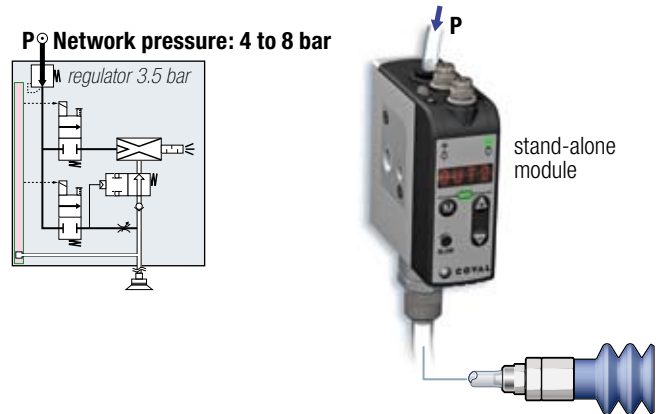

## 2- Island modules

An island may be convenient for feeding vacuum pads following different sequences.

These modules are to be banked together to form a compact island block. The common pressure thru the island supplies each module which receives its own controls and feeds its own set of vacuum pads.

On the contrary to stand-alone modules, island modules have no integrated pressure regulator. This is why the optimum pressure to feed the island is 4 bar.

See p. 8 and 9 the island part numbers, configurations and fixings.

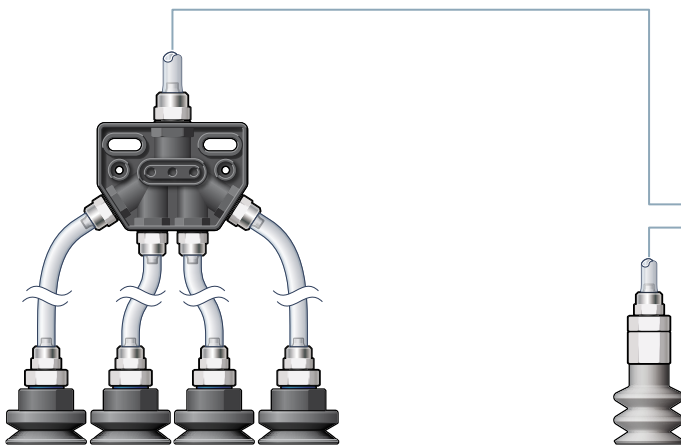
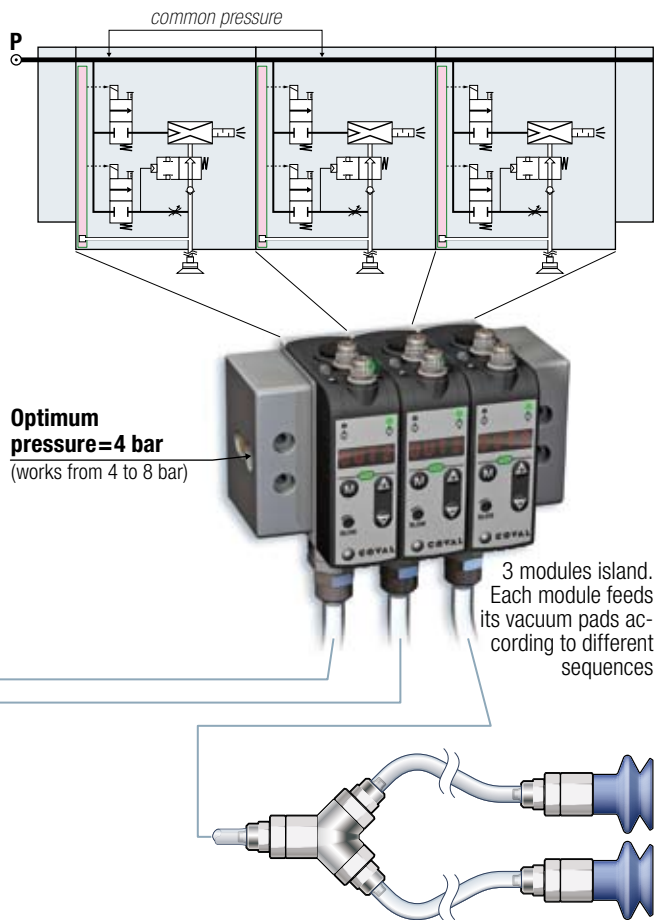

## Long lasting air tight vacuum circuits

With stand-alone or island LEMAX modules, the ASC cycle will keep operating only if the vacuum circuit remains air tight over time.

If this circuit includes tubing that moves respective to the fittings, threaded cap fittings should preferably be used (see below).

### Threaded cap fittings

Screwing the cap (see illustration) tightens the tube onto the fitting sealing barb.

The connection remains air tight, even if the tube is moving respective to the fitting.

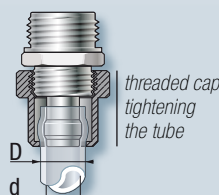

These threaded cap fittings are available into the COVAL catalogue : elbows, Ys, manifolds and straight threaded connectors (illustration), for  $d \times D$  tubes (4 x 6 mm, 6 x 8 mm and 8 x 10 mm).

Tube 4 x 6 mm is flexible and convenient for moving circuits.

# LEMAX series: stand-alone

## Module connections

### ■ Pressure supply

- P = 4 to 8 bar.
- 6mm OD tubing onto push-in connection.

### ■ Electrical connections

- 2 standard M8 connections.
- Standard connectors: see page 10.

### ■ Vacuum circuit connection

- 1/4" BSP threaded port.
- See page 5 recommendations for a long lasting air tight circuit.

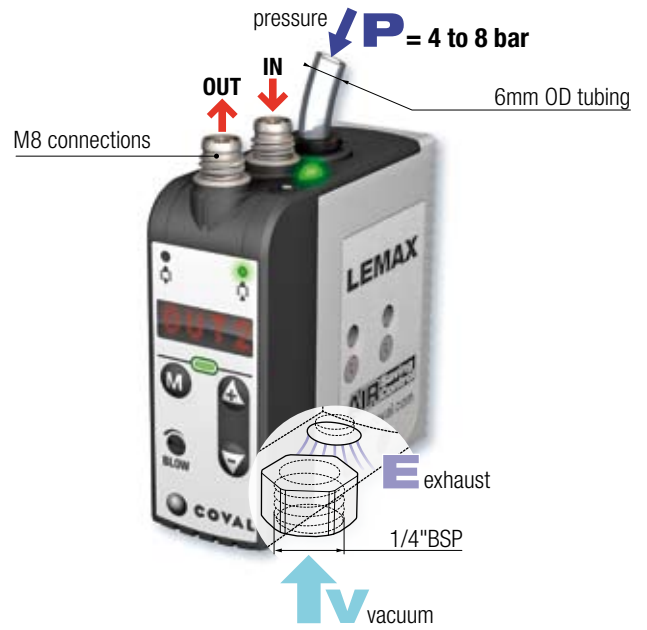

## Choice of fixation

### 1-Fixing from side

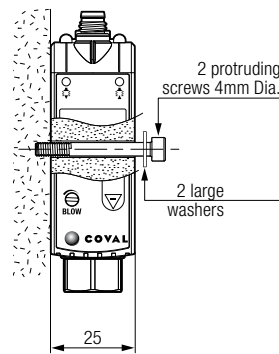
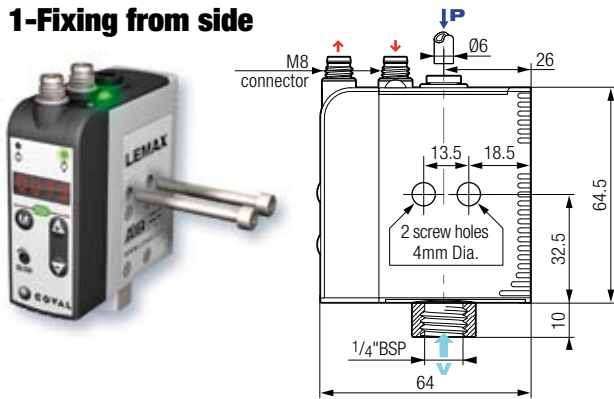

The side fixing is the simplest of all:  
2 protruding screws or bolts with large washers.

### 2- Fixing from front

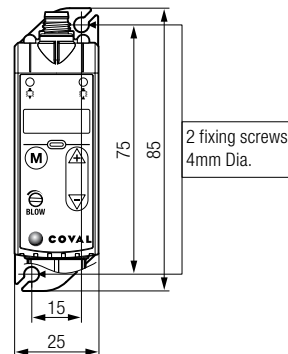
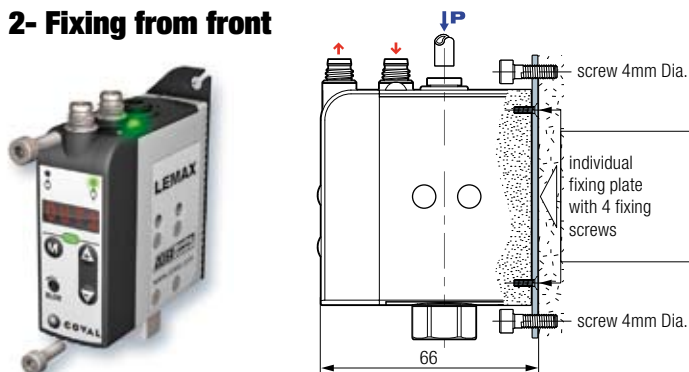

For fixing from front, please order the necessary kit in addition to the ejector module:

Kit for fixing from front:  
1 plate + 4 screws

**REF : LEMFIXA**

### 3- Fixing over a DIN rail

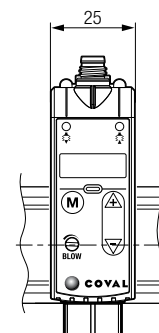
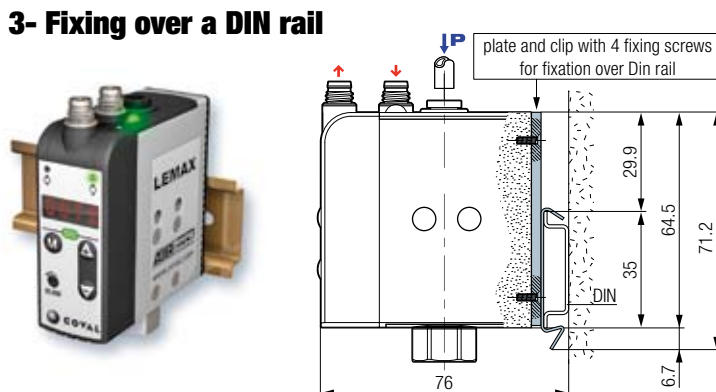

The module may be clipped over a DIN rail.

To do so, the module should be equipped with an individual fixation plate over the DIN rail which is to be ordered separately:

Fixation kit for the DIN rail:  
1 plate/clip + 4 screws

**REF : LEMFIXB**

# modules choice

<b>LEMAX</b>	<b>90</b>	<b>X</b>	<b>14</b>		<b>S</b>
--------------	-----------	----------	-----------	--	----------

Composed module part number

## VACUUM LEVEL

90% max. vacuum  
optimum for air tight products

**90**

## MODULE COMPOSITION

**S**

Vacuum pump controlled by a  
Normally Closed solenoid valve (NC)

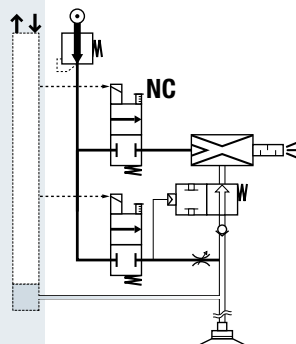

LEMAX90X\_**S**

- In case of electrical cut-off, the vacuum generation stops.

- Blow-off programmed on-site. Choice between :  
- either blow-off controlled by specific signal.  
- or automatic blow-off with 0 to 3 s adjustable time → only one signal for vacuum and blow-off.

**V**

Vacuum pump controlled by a  
Normally Open solenoid valve (NO)

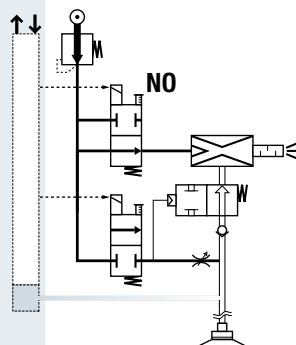

LEMAX90X\_**V**

- In case of electrical cut-off, the vacuum generation goes on.  
→ Product holding is maintained for security

- Blow-off is controlled by specific signal.



## NOZZLE DIAMETER

nozzle 1.4mm ID	<b>14</b>
nozzle 1.2mm ID	<b>12</b>
nozzle 1.0mm ID	<b>10</b>

nozzle ID

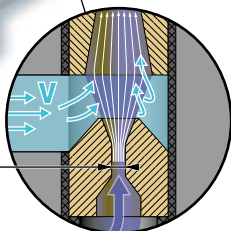

## Nozzle diameter choice

Nozzle dia.	Venturi characteristics while working without ASC		"ASC" working: - gripping at 65% vacuum - vacuum stop at 75%		
	sucked air	consumed air	gripping time (65% vac.)	time until 75% vac.	consumed air
1.4 mm	70 NI/mn	90 NI/mn	0.99 s	1.38 s	2.2 NI
1.2 mm	45 NI/mn	65 NI/mn	1.53 s	2.15 s	2.2 NI
1.0 mm	29 NI/mn	44 NI/mn	2.38 s	3.33 s	2.2 NI

### Conclusions :

- A big nozzle provides a quicker grip, without consuming more, as long as ASC is maintained.
- A small nozzle consumes less only when production is carried on without ASC.

## EXEMPLE OF COMPOSED PART NUMBERS: LEMAX90X14S

LEMAX "ASC" compact vacuum pump, 90% maximum vacuum, 1.4m Dia. nozzle, controlled by a Normally Closed solenoid valve.

## SPECIFIC COMPLEMENTARY OPTIONS:

Island of banked modules: see pages 8 and 9.

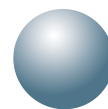

**COVAL**  
vacuum managers

# LEMAX series: island

## Island composition

The island modules are modularly banked to form a compact island.

Each module is separately controlled in order to feed its vacuum pad(s) according to the required sequence.

The island is crossed by the pressure common that feeds each module. This common receives pressure at one end or the other, or at both ends if needed.

The maximum number of modules in an island depends of the power of the modules that must be active simultaneously:

- 5 modules maximum for nozzle 1.4 mm ID.
- 7 modules maximum for nozzle 1.2 mm ID.
- 9 modules maximum for nozzle 1.0 mm ID.

A part number may be defined and ordered (see next page) for islands with identical modules. Such islands will be delivered all assembled.

For islands with different modules, the order will list the part number for each module and the island ends set part number (see next page). The island will easily be assembled on site (see illustration) with the modules position to fit the application needs.

3 modules island

**P optimum : 4bar**  
(working from 4 to 8 bar)



LEM MAX island modules (identical or different)

3 modules islands



island ends set

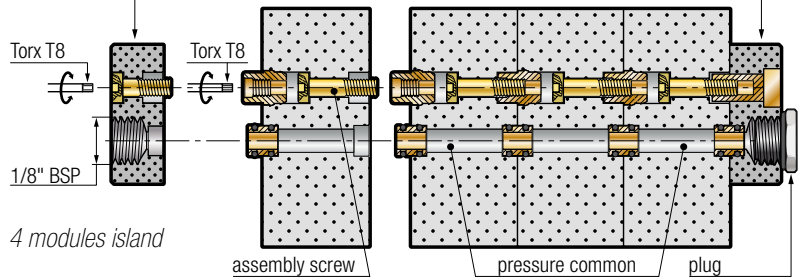

4 modules island

## Island fixation choice

An island is fixed by its 2 ends, either from front with protruding screws or bolts or clipped over a DIN rail, with an additional fixing set to be ordered separately.

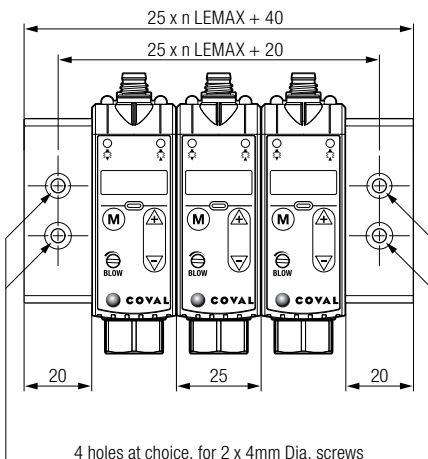

**1- Fixing from front**

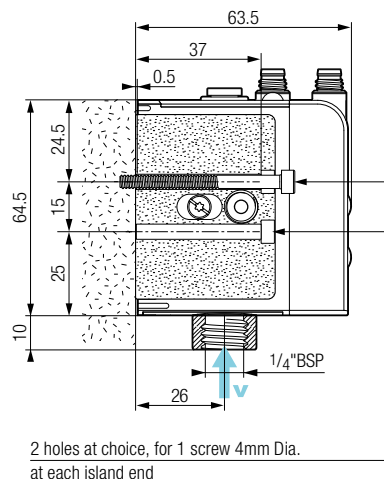

2 holes at choice, for 1 screw 4mm Dia. at each island end

**2- Fixing over a DIN rail**

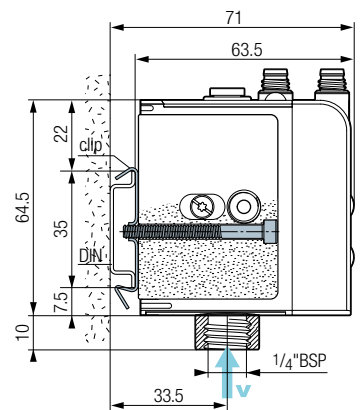

Fixation kit for the DIN rail:  
2 clips + 2 screws

**REF : LEMFIXC**



# configuration

**LEMAX 90 X 14 S B3**

**Composed part number for an island or an island module**

## VACUUM LEVEL

90% max. vacuum optimum for air tight products

**90**

## NOZZLE DIAMETER

nozzle 1.4 mm ID	<b>14</b>
nozzle 1.2 mm ID	<b>12</b>
nozzle 1.0 mm ID	<b>10</b>

## MODULE COMPOSITION

**Vacuum pump controlled by a Normally Closed solenoid valve (NC)**

**S**

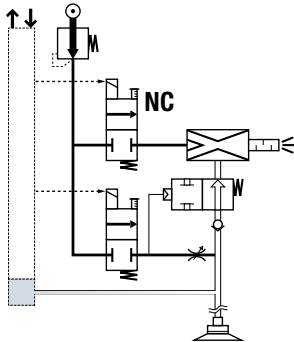

LEMAX90X\_\_**S**\_\_

- In case of electrical cut-off, the vacuum generation stops.
- Blow-off to be configured at choice:
  - with specific control signal.
  - automatic, with 0 to 3 s timing

**Vacuum pump controlled by a Normally Open solenoid valve (NO)**

**V**

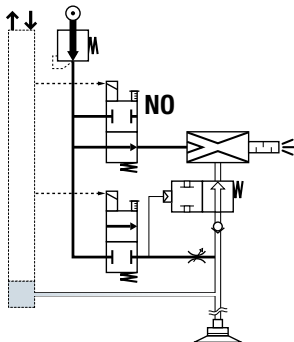

LEMAX90X\_\_**V**\_\_

- In case of electrical cut-off, the vacuum generation goes on.
- Product holding is maintained:
  - positive security.
- Blow-off controlled with specific signal.

## ASSEMBLED ISLANDS

**B2**



LEMAX90X\_\_**B2**

Assembled island with 2 identical modules.

**B3**



LEMAX90X\_\_**B3**

Assembled island with 3 identical modules.

**B4** ...

*If the required island includes modules of different types, the order must list all components part numbers, to be later assembled on site, to the application needs.*

## NON-ASSEMBLED ISLAND COMPONENTS

**B**



LEMAX90X\_\_**B**

Island module, complete with integrated assembly screw.



Island ends set complete with assembly screw and plug for pressure common.

**REF : LEMSETA**

## EXAMPLE OF NON-ASSEMBLED ISLAND ORDER:

- **LEMAX90X14VB**
  - **LEMAX90X12SB**
  - **LEMAX90X10VB**
- 3 LEMAX island modules of different types.
- **LEMSETA** → Island ends set.

## EXAMPLE OF ASSEMBLED ISLAND PART NUMBER:

■ **LEMAX90X14SB3**

LEMAX assembled island with 3 modules 90% max. vacuum, 1.4m ID nozzle, controlled by a Normally Closed solenoid valve.

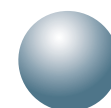

**COVAL**  
vacuum managers

# LEMAX series: characteristics

## General characteristics

- C.A. supply 5μ filtered, non-lubricated air relevant to ISO 8573-1 class 4 standard.
- Optimal working pressure: 4 to 8 bar.
- Blow-off: adjustable flow
  - stand-alone modules: P = 3.5 bar.
  - island modules: P supply.
- Maximum vacuum: 90%.
- Suction flow rate: from 29 to 70 NI/mn.
- Air consumption: from 44 to 90 NI/mn when working "without ASC".
- Integrated non clogable open silencer.
- Sound level: about 68 dBA "without ASC", 0 dBA with ASC.
- Electrical degree of protection: IP65.
- Maximum frequency of utilization: 4 Hz.
- Number of operations: 10 million cycles.
- Weight: 130 g.
- Working temperature: from 10 to 60°C.
- Materials: PA 6-6 15%FG, brass, aluminium, NBR.

## Electrical controls

- Voltage tension: 24 V DC (adjustable ± 10 %).
- Current draw: 30 mA (0,7W) vacuum or blow-off.

## Integrated electronic

- Supply: 24 V DC ; current draw: <57mA.
- Measure range: 0 to 99 % vacuum.
- Measure precision: ±1,5 % of the range, temperature compensated.
- Display: 4-Character LED dot matrix, red.

## Service characteristics

### "Gripped product" output signal

- 24V DC NO switching output, power: 125 mA PNP.

### Configurable auxiliary output

- either "without ASC" signal +5V DC NO switching output.
- or "vacuum level" signal, analogic 0 to 5V DC, along the 0 to 99 % vacuum measure range.

### Displays

- Scrolling display: 4-Character LED dot matrix, red.
- Language configuration: FR, ENG, D, IT or ES.
- Blinking "ASC missing" signal for maintenance.
- Visual indicators: "vacuum" = green LED, "blow-off" = red LED.
- "Gripped product" visual indicator: green LED in front.

### Configurations

- Through adjustment keys and running display (see p.4).
- Language selection.
- Blow-off choice: controlled, or automatic timed 0 to 3s.

### Settings

- Display of cycles number (vacuum cycles counter).
- If required by the application, threshold and hysteresis settings when different from initial factory setting (V1=65%, H1=10%, V2=75%, H2=10%).

### Autoreactivity

- Continuous control of vacuum leaks level: automatic override or return to "ASC" regulation.

## Electrical connections and corresponding configurations

### configurable auxiliary output

- "without ASC" signal +5V DC switching output NO
- OR (configuration)
- "vacuum level" signal analogic 1 to 5V DC

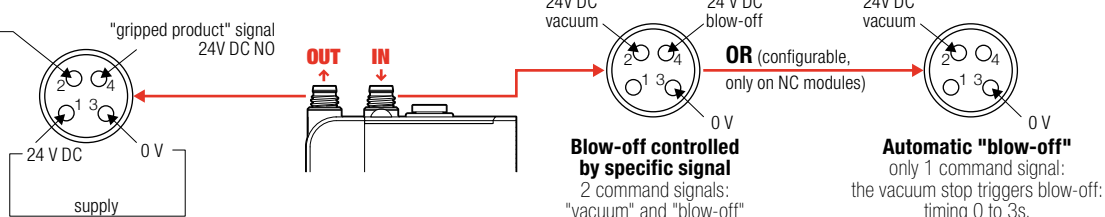

## M8 electrical connectors

### CHARACTERISTICS:

- screw type female connectors.
- 2m PVC cable, pre-assembled four-wire.
- protection IP65.

### CONNECTOR WIRING:



### REFERENCES:

- straight CDM8
- elbow CCM8

### SPECIAL CONNECTORS ON REQUEST:

- PUR cable.
- 5 or 10 m length.

## Gripping safety: vacuum command with a NC solenoid valve or a NO solenoid valve ?

Both presented on p. 7 and 9, these 2 variants have a different behaviour in case of electrical cut-off:

- with a NC solenoid valve, vacuum stops being generated: the product is hardly maintained by the non-return valve on vacuum.

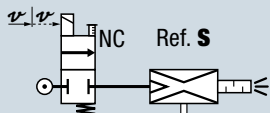

- with a NO solenoid valve, vacuum goes on being generated to imperiously maintain the product gripping.

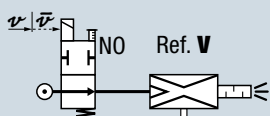

Both variants **S** and **V** are controlled by the same  $v$  signal (vacuum). In fact, on the NO variant that must be piloted when there is no need for vacuum, this  $v$  signal is internally inverted to  $\bar{v}$ .

The NO variant (ref. **V**) is recommended for applications where the product gripping must imperiously be maintained in case of electrical cut-off, even if there are leaks on the vacuum circuit (positive safety).

However, this NO variant does not offer the automatic timed blow-off option which enables to command the modules through a single "vacuum + blow-off" signal.

# LEMAX series: applications

The LEMAX series mini-module vacuum pumps offer a new approach to vacuum handling in numerous domains: packaging, robotics, clamping, transfers, plastic molding, etc ...

Optimized to serve small and medium sized suction pads, LEMAX helps to simplify the installation while integrating all control functions into a single light weight mini-module, placed close to the suction pads.

Integrated to all LEMAX modules, the "ASC" autoregulation automatically provides a 60 to 99 % energy economy, when handled products are air tight. If porous products are also handled, the normal production goes on, but without "ASC".

The LEMAX series is thus applied on installations handling air tight products: glass, plastics, coated wood, metal sheets, etc ... The energy economies pay for the investment in a few months only.

However, the LEMAX series may also be applied to mixed machines, that may receive air tight and porous products: the adaptation to the type of product is totally automatic.

## PACKAGING MACHINES

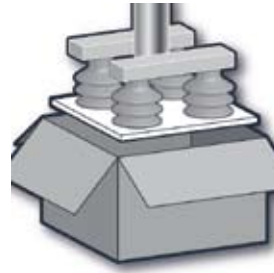

CLAMPING

## ROBOTIC HANDLING TOOLS



PLASTIC INDUSTRY

# LEM+LEMAX: 2 complementary series

## LEM series

- **Series convenient for all grippings:**
  - Porous products: cardboard, raw wood, pastries, etc ...
  - Air tight products, when LEMAX is not applied.
- **Many configurations :**
  - 60 and 90 % maximum vacuum.
  - With or without vacuum sensor.
  - With or without blow-off.



## The 2 series common advantages

- **Integration:** all necessary functions are integrated into a complete mini-module.
- **Intelligence :** integrated electronic for configuration to the application and automatic follow-up.
- **Complete ranges to suit all applications:**
  - Power choice: nozzle ID 1mm, 1.2mm and 1.4 mm.
  - Installations choice with:
    - stand-alone modules (illustrations on left).
    - island modules (illustration below).

## LEMAX series

- **Series convenient for all air tight products gripping:**
  - The ASC autoregulation saves 60 to 99% energy automatically.



Island gathering LEM modules and LEMAX modules



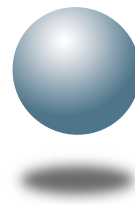

**COVAL**  
vacuum managers

## vacuum components



### A TECHNOLOGICAL PARTNER ON A GLOBAL SCALE

Located in the southeast region of France, COVAL conceives, manufactures and globally distributes high performance, advanced vacuum automation components and systems for industrial applications in all branches.

COVAL is an ISO 9001: V2008 certified company which offers innovative solutions integrating reliable and optimized components with intelligent functionalities. The focus is to provide the most personalized and economic solution to a given application while assuring a significant improvement in the productivity and the safety for the vacuum users around the world.

COVAL has an ambition for technical excellence and innovation. As a specialist in vacuum automation, COVAL is reputed for offering reliable, personalized, cost effective and productive solutions.

The references of COVAL can be found in several industrial sectors (Packaging, Automotive Industry, Plastic, Graphic, Aeronautic...) where vacuum handling is important for high efficiency and productivity.

COVAL markets its products and services all over Europe, in the United States and South America through its subsidiaries and authorized distribution network. COVAL strives to provide customer driven solutions and gives the best possible treatment to satisfy all its clients.

*For all enquiries from Australia, Africa and Asia kindly contact COVAL head office in France.*

Distributed by:



certified quality  
management system

COVAL VACUUM TECHNOLOGY INC.  
212-112 Powell Drive  
Raleigh, NC 27606  
Phone : (919) 233-4855  
Fax : (919) 233-4854

[www.coval-inc.com](http://www.coval-inc.com)