

**Manufacturers of Quality Automation
Components for Over 20 Years!**



O-Ring Grippers
Parallel Grippers
Angular Grippers
Rotary Actuators
Linear Slides
Linear Thrusters
Feed Escapements



www.agi-automation.com

Parallel Grippers

2-Jaw

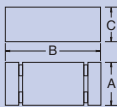
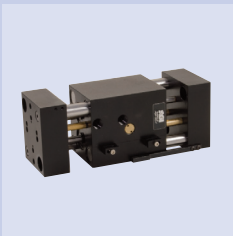
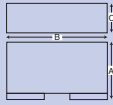

Model#	Stroke	A	B	C
AGP-6-OR	.640"	2.775	2.580	2.580
AGP-8-OR	1.10"	5.00	5.00	5.00
AGPM-1	.190"	.945	.768	.630
AGLP-1, 2	1/4, 1/2"	1.164	1.750	.750
AGLP-3, 4	3/4, 1"	1.283	3.150	.875
AGP-187	.16"	1.437	1.00	1.125
AGP-250	1/4"	1.470	1.500	1.250
AGP-375	3/8"	1.402	2.500	1.500
AGP-500	1/2"	1.863	3.187	1.625
AGPT-500	1/2"	1.840	2.250	1.000
AGPT-1000	1"	2.340	3.250	1.000
AGPT-1125	1.125"	3.192	3.125	1.250
AGW-250	3/4"	1.625	2.890	1.250
AGW-375-1	1"	2.000	4.740	1.500
AGW-375-2	2"	2.000	5.380	1.500
AGW-375-4	4"	2.000	7.380	1.500
AGW-500-1	1-1/2"	2.625	6.730	2.250
AGW-500-2	2-1/2"	2.625	9.230	2.250
AGW-500-4	4"	2.625	13.230	2.250
AGW-625-2	2"	2.750	8.500	2.750
AGW-625-4	4"	2.750	14.50	2.750
AGW-625-6	6"	2.750	16.50	2.750

3-Jaw

AGP-23	.30"	1.45	2.00	2.00
AGP-43	.40"	1.81	2.75	2.75
AGP-63	.62"	2.56	3.75	3.75
AGP-83	.88"	3.20	4.72	4.72

Angular Grippers

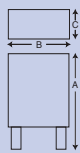

2-Jaw 180°

Model#	Stroke	Per Jaw Grip Force	A	B	C
AGA-20	180°	30 lbs.	2.64	1.53	1.10
AGA-30	180°	75 lbs.	3.46	2.20	1.70
AGA-40	180°	180 lbs.	4.00	3.00	2.00
AGA-50	180°	700 lbs.	6.00	4.00	2.75
AGA-60	180°	820 lbs.	6.00	4.00	3.50



3-Jaw 180°

Model#	Stroke	Per Jaw Grip Force	A	B	C
AGA-23	180°	30 lbs.	2.7	1.75	1.75
AGA-34	180°	75 lbs.	3.8	2.43	2.43
AGA-43	180°	180 lbs.	4.7	3.00	3.00
AGA-53	180°	700 lbs.	6.0	4.50	4.50

Rotary Actuators

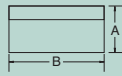

Model#	Torque @ 80 psi	A	B	C
AGR-1	5 in-lbs.	.969	2.250	2.25
AGR-2	17 in-lbs.	1.313	3.375	3.375
AGR-2P				
AGR-2H				
AGR-3	50 in-lbs.	1.720	4.622	3.000
AGR-4	100 in-lbs.	2.125	5.500	3.500
AGR-5	248 in-lbs.	2.765	8.50	4.625

Power Slides

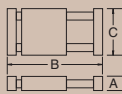

Model#	Max. Stroke	A	B	C
AGS-4	4" adj.	1.000	See Specs.	3.500
AGS-5	5" adj.	1.250	See Specs.	4.500
AGS-6	6" adj.	1.750	See Specs.	5.000

Linear Thrusters

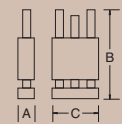

Model#	Max. Stroke	A	B	C
AGT-2	4"	0.910	See Specs.	3.212
AGT-3	6"	1.500	See Specs.	3.375
AGT-4	8"	2.000	See Specs.	4.250
AGT-5	12"	2.375	See Specs.	5.500

Mini Powered Slides

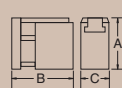

Model#	Max. Stroke	A	B	C
AGMS-1-1	1/2"	1.281	2.31	.860
AGMS-1-2	1"	1.281	3.31	.860
AGMS-1-3	1-1/2"	1.281	4.31	.860
AGMS-1-4	2"	1.281	5.31	.860
AGMS-2-1	1/2"	1.60	2.31	1.06
AGMS-2-2	1"	1.60	3.31	1.06
AGMS-2-3	1-1/2"	1.60	4.31	1.06
AGMS-2-4	2"	1.60	5.31	1.06

Feed Escapements

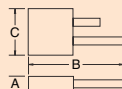

Model#	Stroke	A	B	C
AGE-1	1"	1.000	4.18	1.87
AGE-2	1 1/4"	1.125	5.10	2.25
AGE-3	1 1/2"	1.370	5.63	2.75

Gripper & Rotary Modules

Multi-Motion Actuators provide linear and rotary motion from one unit. The grip-and-turn motions are independent from one another, making it easy to sequence the two motions. The Multi-Motion Module yields a versatile automation module for part pick and place applications and orientation operations. Internal porting prevents airlines from twisting, snagging, and breaking outside the unit.



Rotary	+	Gripper	=	Part #
AGR-1-90	+	AGP-250	=	AGM-1
AGR-1-180	+	AGP-250	=	AGM-2
AGR-2-90	+	AGP-250	=	AGM-3
AGR-2-180	+	AGP-250	=	AGM-4
AGR-2-90	+	AGP-375	=	AGM-5
AGR-2-180	+	AGP-375	=	AGM-6
AGR-2-90	+	AGP-500	=	AGM-7
AGR-2-180	+	AGP-500	=	AGM-8
AGR-2-90	+	AGW-250	=	AGM-9
AGR-2-180	+	AGW-250	=	AGM-10
AGR-3-90-M	+	AGW-375-1	=	AGM-11
AGR-3-180-M	+	AGW-375-1	=	AGM-12
AGR-3-90-M	+	AGW-375-2	=	AGM-13
AGR-3-180-M	+	AGW-375-2	=	AGM-14
AGR-3-90-M	+	AGW-375-4	=	AGM-15
AGR-3-180-M	+	AGW-375-4	=	AGM-16

A total of 80 possible combinations available online

**For detailed product specifications and CAD drawings,
please visit our website at www.AGI-Automation.com**

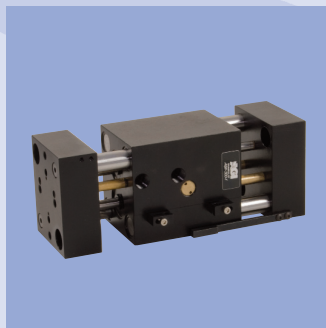
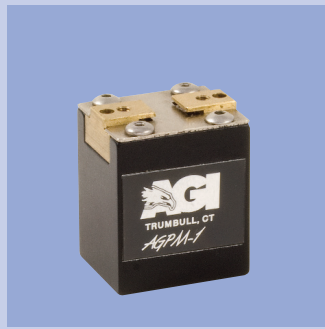

Parallel Grippers

- AGP-OR Series**
- AGPM Series**
- AGLP Series**
- AGP Series**
- AGPT Series**
- AGW Series**
- AGM Series**





Dual Motion Grippers

Pick and Seat

Innovative tools for automated 'O'-ring and/or seal installation

Available in the following sizes:

AGP-6-OR. A six jaw/six ejector, multi-motion unit, that handles up to 3.000" i.d. seals and/or 'O'-rings. This unit has independent spreading and ejector movements.

AGP-8-OR. An eight jaw/eight ejector, multi-motion, thru-hole unit, that handles up to 12.000" i.d. seals and/or 'O'-rings. This unit has the same independent spreading and ejector movements of the AGP-6-OR, but offers both the capacity for larger diameter 'O'-rings as listed and a 1.500" diameter thru-hole for requirements that deal with long shaft installations/assemblies.

Both the AGP-6-OR & the AGP-8-OR are designed to facilitate part ejection and part seating, which may become necessary after 'O'-ring/seal placement.

Function:

These tools have two independent pneumatic pistons; the parallel jaws, or spreading jaws, which are double acting, and the ejector jaws, which are single acting. In 'O'-ring installation applications, the air pressure is applied to the first piston which facilitates the spreading jaws' expansion of the 'O'-ring in either a hexagonal or octagonal shape. [An 'O'-ring expanded in this manner offers considerably less deformation during the assembly insertion process.] Once the 'O'-ring is expanded and over the target, air pressure is applied to the second piston. This causes the ejector jaws to push the 'O'-ring away from the spreading jaws, and thus into or onto the assembly.

These 'O'-ring-installing units can be tooled to accommodate all types of rings/seals, ranging from the minute to 12.000" in diameter. The opening stroke of the spreading jaws can also be adjusted via a set-screw to prevent over-expansion. End of stroke sensing is available for both spreading and ejector jaws.

Dimensions:

AGP-6-OR - 2.500" diameter x 2.700" length.

Spreading jaws - 62 lbs. of force.

Ejector jaws - 80 lbs. of force.

AGP-8-OR - 5.000" diameter x 5.000" length.

Spreading jaws - 200 lbs. of force.

Ejector jaws - 320 lbs. of force.

[Note: Forces given @80 psi.]

Two and 3D CAD drawings available on our web site, www.agi-automation.com

AGP-6-OR



AGP-8-OR



Typical Placement Example

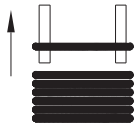

1.) O-rings are located in a nest or fixture and tooling jaws enter I.D.

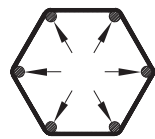

2.) Parallel tooling jaws spread o-ring to the need diameter.

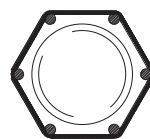
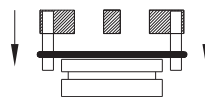

3.) Passing over the part, the ring can be brought to the groove.

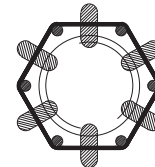
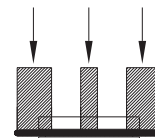

4.) Ejector jaws move forward pushing o-ring from jaws onto part.

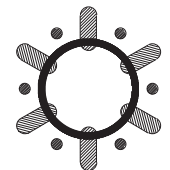
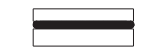

5.) O-ring seal installed on part.

Detailed product specifications and CAD drawings on following pages.



AGP-6-OR Parallel Gripper

6-Finger Gripper for Placing O-Rings, T-Slot Bearing Series



FEATURES AND BENEFITS

- Jaws are T-Slot bearing supported to prevent jaw breakage and offer superior load bearing performance.
- Spreading jaws and Ejector jaws have independent pistons to provide exact timing of O-ring placement.
- Compact design with long adjustable stroke.
- True parallel jaw motion for easy tooling.
- Available in Metric only.

SPECIFICATIONS

Design: Parallel, Double Acting, Synchronized Sealed Jaws

Stroke: Spread 0.6 in. adj. [15 mm]
Ejecting 0.25 in [6.3 mm]

Gripping Force Per Jaw @ 80 PSI [5.5 BAR]
Spreading Jaw: 62 lbs [275 N]
Ejector Jaw: 80 lbs [355 N]

Time:
Close: 0.2 sec [0.2 sec]
Open: 0.2 sec [0.2 sec]

Pressure Range:
Low/High 30-100 PSI [2-7 BAR]

Temperature Range:
Low/High -20°/180°F [-28°/80°C]

Side Play: ± 0.001 [.03 mm]

Repeatability from center: ±.002 [.06 mm]

Loading Capacity:

	Static	Dynamic
Max Tensile T	60 lbs [260 N]	20 lbs [88 N]
Max Compressive C	60 lbs [260 N]	20 lbs [88 N]
Max Moment M_x	100 in/lb [11 Nm]	25 in/lb [2.7 Nm]
Max Moment M_y	120 in/lb [13 Nm]	30 in/lb [3.3 Nm]
Max Moment M_z	100 in/lb [11 Nm]	25 in/lb [2.7 Nm]

Material: High Strength, Hard Coated aluminum bronze alloys, Steel

Weight: 1.25 lbs [.56 Kg]

Piston Diameter: 1.00 in [25.4 mm]

January 2009 - PATENTED Made in the USA

HOLDING FORCES CHART

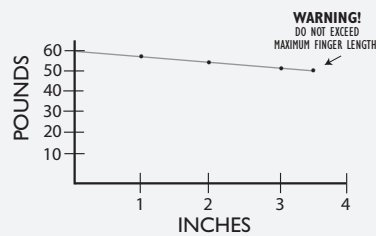

WARNING! Do not exceed tooling jaw length. See Chart above.

LOADING INFORMATION

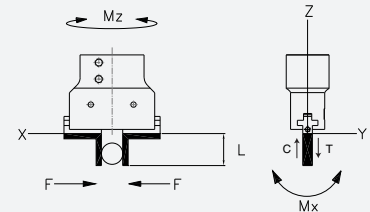

LOOK! More Technical specifications for sensors on "Sensors Accessories" page.

HOW TO ORDER

When ordering, please specify:
Design/Model Number and Options.

DESIGN/MODEL
AGP-6-OR

SENSOR TYPE*

- 1 = NPN
- 2 = PNP

AGP-6-OR - 3 - 1 - 1

SENSOR OPTIONS

- 1 = JAW OPEN
- 2 = EJECTOR DOWN
- 3 = BOTH

SENSOR CONNECTOR

- 1 = POTTED
- 2 = QUICK DISCONNECT
- 3 = QUICK DISCONNECT WITH RIGHT ANGLE

* NOTE: Proximity sensors are 4 mm dia., 12-30 VDC, 50 mA and comes with 2 meter cable.

Sensor Part # SNC06, SNQ06, SPC06, SPQ06

AGP-6-OR Parallel Gripper

6-Finger Gripper for Placing O-Rings, T-Slot Bearing Series

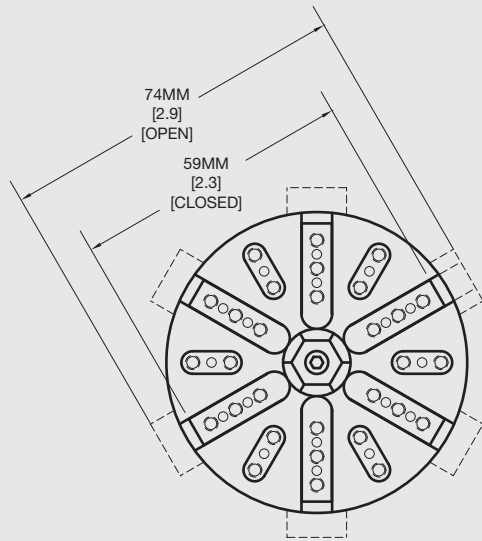

METRIC PROJECTION

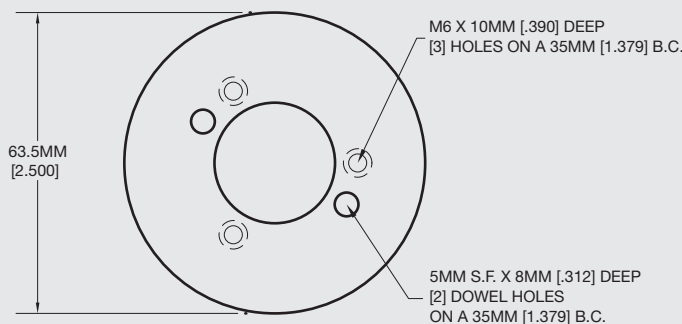
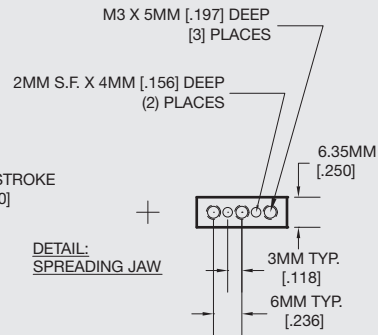
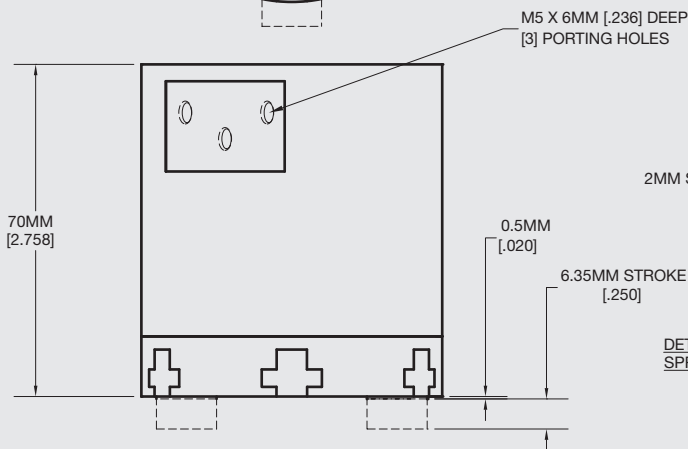
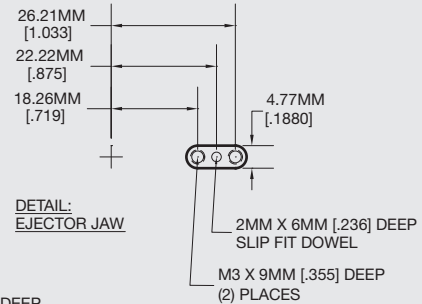

Unless noted, all tolerances are as indicated here:



All Dowel Holes are SF (Slip Fit) Locational Tolerance $\pm .0005$ " [.013mm]



Metric Threads Course Pitch

Imperial: Inch

0.00 = $\pm .01$
0.000 = $\pm .005$
0.0000 = $\pm .0005$

Metric: [0.] = $\pm .25$
[0.0] = $\pm .13$
[0.00] = $\pm .013$



AGP-8-OR Parallel Gripper

8-Finger Gripper for Placing O-Rings, T-Slot Bearing Series



FEATURES AND BENEFITS

- Jaws are T-Slot bearing supported to prevent jaw breakage and offer superior load bearing performance.
- Spreading jaws and Ejector jaws have independent pistons to provide exact timing of O-ring placement.
- Compact design with long adjustable stroke.
- True parallel jaw motion for easy tooling.
- Hole through center facilitates part seating and ejection.
- Available in Imperial only.

SPECIFICATIONS

Design: Parallel, Double Acting, Synchronized Sealed Jaws

Stroke: Spread 1.10 in. adj. [27.9 mm]
Ejecting 0.55 in [13.9 mm]

Gripping Force Per Jaw @ 80 PSI [5.5 BAR]

Spreading Jaw: 200 lbs [889 N]

Ejector Jaw: 310 lbs [1378 N]

Time:

Close: 0.2 sec [0.2 sec]

Open: 0.2 sec [0.2 sec]

Pressure Range:

Low/High 30-100 PSI [2-7 BAR]

Temperature Range:

Low/High -20°/180°F [-28°/80°C]

Side Play: ± 0.001 [.03 mm]

Repeatability from center:

±.002 [.06 mm]

Loading Capacity:

	Static	Dynamic
Max Tensile T	100 lbs [445 N]	30 lbs [130 N]
Max Compressive C	100 lbs [445 N]	30 lbs [130 N]
Max Moment M_x	200 in/lb [22 Nm]	50 in/lb [6 Nm]
Max Moment M_y	230 in/lb [23 Nm]	60 in/lb [6 Nm]
Max Moment M_z	200 in/lb [22 Nm]	50 in/lb [6 Nm]

HOLDING FORCES CHART

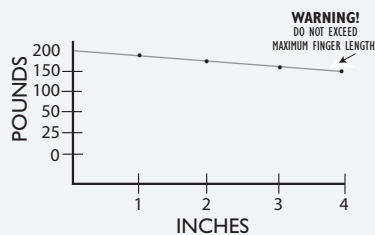

WARNING! Do not exceed tooling jaw length. See Chart above.

LOADING INFORMATION

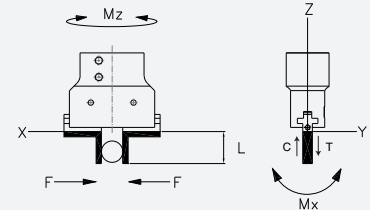

LOOK! More Technical specifications for sensors on "Sensors Accessories" page.

HOW TO ORDER

When ordering, please specify:
Design/Model Number and Options.

DESIGN/MODEL

AGP-6-OR
AGP-8-OR

SENSOR TYPE*

1 = NPN
2 = PNP

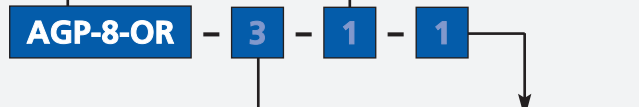

SENSOR OPTIONS

1 = JAW OPEN
2 = EJECTOR DOWN
3 = BOTH

SENSOR CONNECTOR

1 = POTTED
2 = QUICK DISCONNECT
3 = QUICK DISCONNECT WITH RIGHT ANGLE

* NOTE: Proximity sensors are 4 mm dia., 12-30 VDC, 50 mA and comes with 2 meter cable.

Sensor Part # SNC06, SNQ06, SPC06, SPQ06



AGP-8-OR Parallel Gripper

8-Finger Gripper for Placing O-Rings, T-Slot Bearing Series

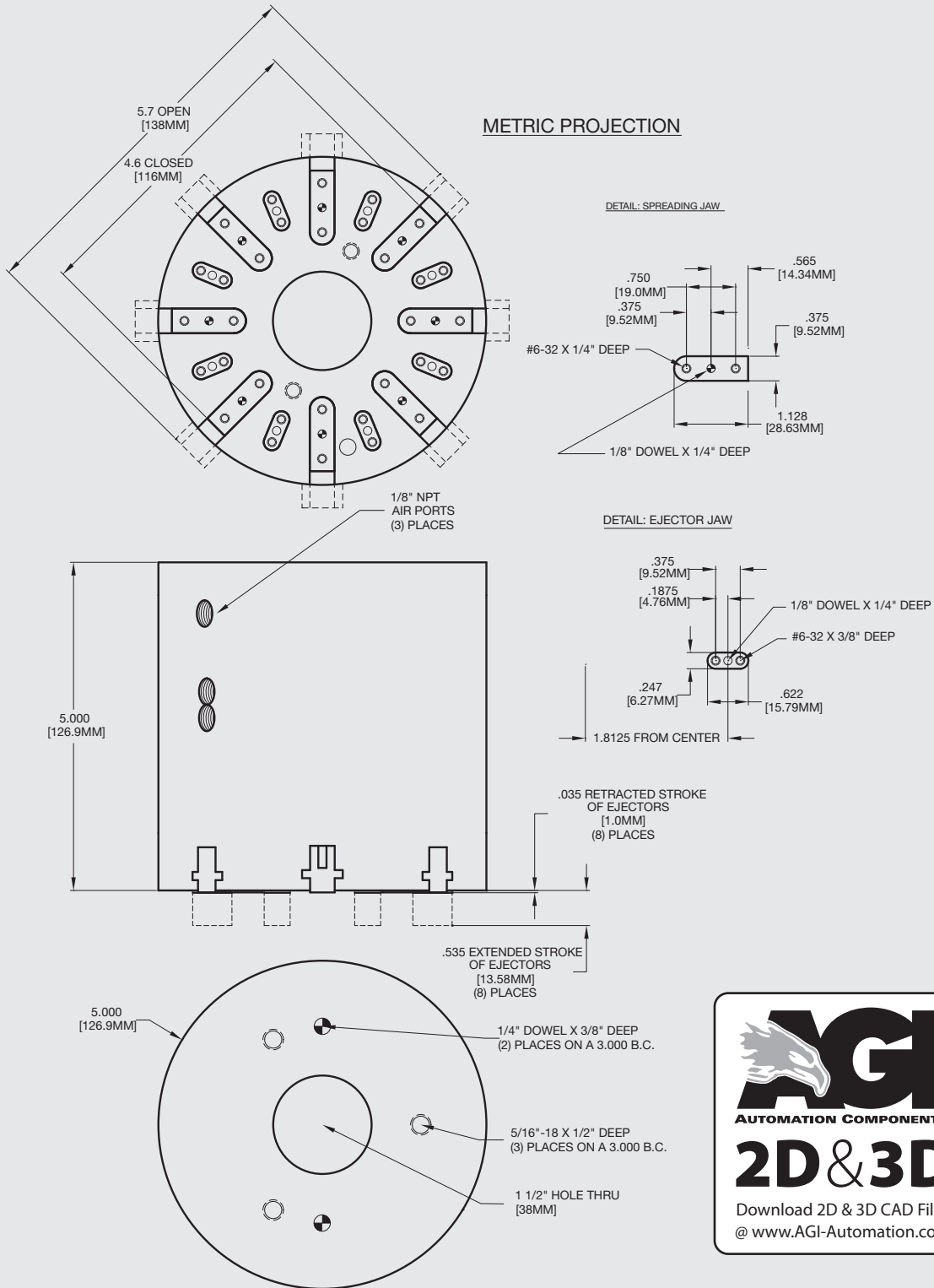

Unless noted, all tolerances are as indicated here:



All Dowel Holes are SF (Slip Fit) Locational Tolerance $\pm .0005"$ [.013mm]



Metric Threads Course Pitch

Imperial: 0.00 = $\pm .01$
 Inch 0.000 = $\pm .005$
 0.0000 = $\pm .0005$

Metric: [0.] = $\pm .25$
 [mm] [0.0] = $\pm .13$
 [0.00] = $\pm .013$



AGPM-1 Parallel Gripper

Miniature T-Slot Bearing Series



FEATURES AND BENEFITS

- Jaws are T-Slot bearing supported to prevent jaw breakage and offer superior load bearing performance.
- High gripping force to weight ratio.
- True parallel jaw motion for easy tooling.
- Units are permanently lubricated for non-lube air operation, allowing for compliance with OSHA regulations.
- AGPM-1 is fully field repairable for cost savings and minimum down time.
- Wedge is guided in the body for precise center repeatability.
- Shielded design for long service life.
- Top porting allows unit to be manifolded, eliminating air fittings.
- Purge port on side of unit to evacuate any contaminants from inside for a clean room environment.
- Available in metric only.

SPECIFICATIONS

Design: Parallel, Double Acting, Synchronized Jaws

Stroke: 0.190 in [4.8 mm]

Gripping Force @ 80 PSI [5.5 BAR]

Closing: 9 lbs [40 N]

Opening: 9 lbs [40 N]

Time:

Close: 0.10 sec [0.10 sec]

Open: 0.10 sec [0.10 sec]

Pressure Range:

Low/High 10-100 PSI [.7-7 BAR]

Temperature Range:

Low/High -20°/180°F [-28°/80°C]

Side Play: ± 0.001 [.03 mm]

Repeatability from center:

±.002 [.06 mm]

Loading Capacity:

	Static	Dynamic
Max Tensile T	20 lbs [88 N]	7 lbs [31 N]

Max Compressive C	20 lbs [88 N]	7 lbs [31 N]
-------------------	------------------	-----------------

Max Moment M_x	12 in/lb [1 Nm]	4 in/lb [.5 Nm]
------------------	--------------------	--------------------

Max Moment M_y	15 in/lb [2 Nm]	5 in/lb [.6 Nm]
------------------	--------------------	--------------------

Max Moment M_z	12 in/lb [1 Nm]	4 in/lb [.5 Nm]
------------------	--------------------	--------------------

Material: High Strength, Hard Coated aluminum bronze alloys, Steel

Weight: 1.7 oz. [48.1 g]

Piston Diameter: .437 in [11 mm]

January 2009 - PATENTED Made in the USA

HOLDING FORCES CHART

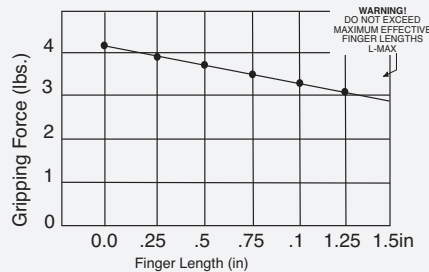

WARNING! Do not exceed tooling jaw length. See Chart above.

LOADING INFORMATION

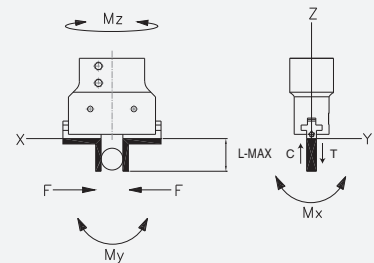

LOOK! More Technical specifications for sensors on "Sensors Accessories" page.

HOW TO ORDER

**When ordering, please specify:
Design/Model Number and Options.**

DESIGN/MODEL
AGPM-1

AGPM-1

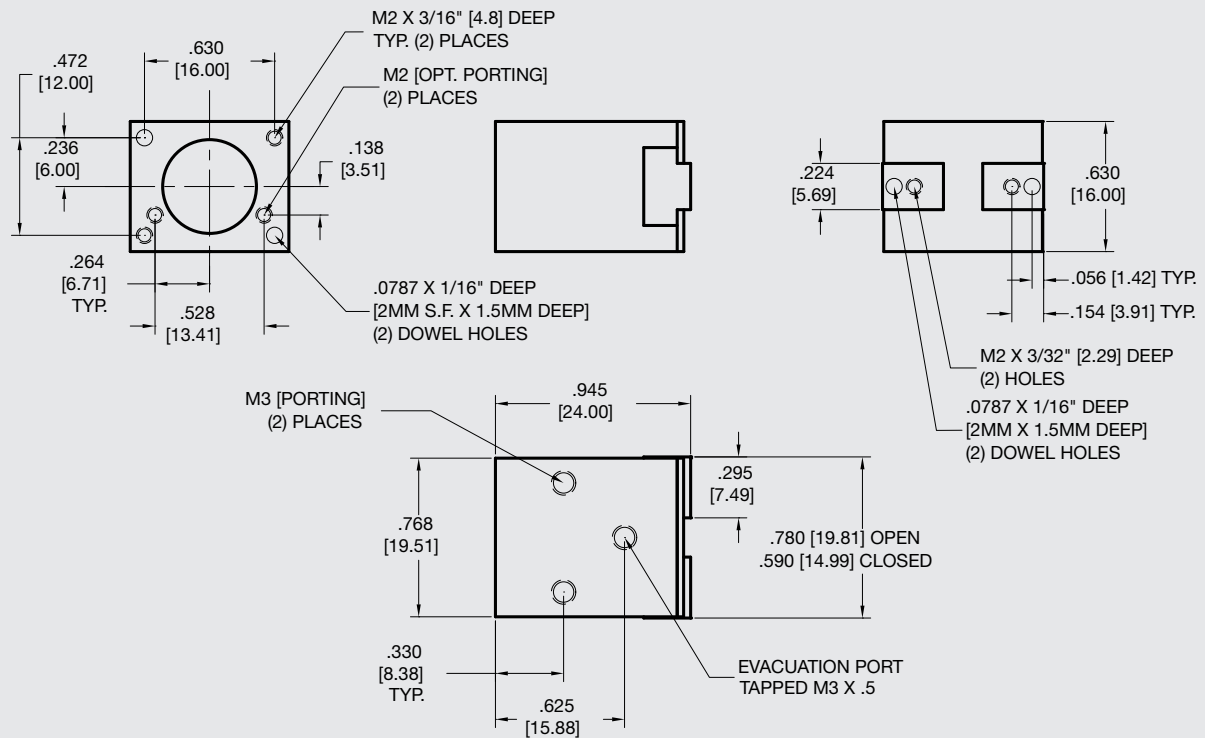

Unless noted, all tolerances are as indicated here:



All Dowel Holes are SF (Slip Fit) Locational Tolerance $\pm .0005"$ [.013mm]



Metric Threads Course Pitch

Imperial:
Inch 0.00 = ± 0.01
0.000 = ± 0.005
0.0000 = ± 0.0005

Metric: [0.] = ± 0.25
[mm] [0.0] = ± 0.13
[0.00] = ± 0.13

AGLP-1 Parallel Gripper

T-Slot Bearing Series, Low Profile

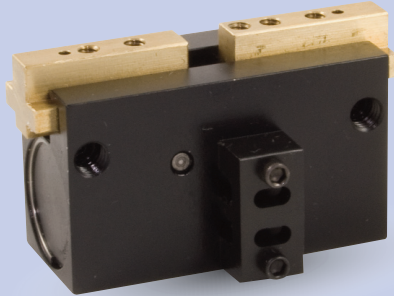

FEATURES AND BENEFITS

- Jaws are T-Slot bearing supported to prevent jaw breakage and offer superior load bearing performance.
- Rugged rack and pinion synchronizing.
- High gripping force to weight ratio.
- Compact design with long stroke.
- True parallel jaw motion for easy tooling.
- Units are permanently lubricated for non-lube air operation, allowing for compliance with OSHA regulations.
- Hall effect sensors are available to monitor open and closed position of the jaws.
- AGLP is fully field repairable for cost savings and minimum down time

SPECIFICATIONS

Design: Parallel, Double Acting, Synchronized Jaws

Stroke: 0.25 in [6.4 mm]

Gripping Force @ 80 PSI [5.5 BAR]

Closing: 10 lbs [44 N]
 Opening: 10 lbs [44 N]

Time:

Close: 0.12 sec [0.12 sec]
 Open: 0.12 sec [0.12 sec]

Pressure Range:

Low/High 10-100 PSI [.7-7 BAR]

Temperature Range:

Low/High -20°/180°F [-28°/80°C]

Side Play: ± 0.001 [.03 mm]

Loading Capacity:

	Static	Dynamic
Max Tensile T	65 lbs [289 N]	20 lbs [89 N]
Max Compressive C	65 lbs [289 N]	20 lbs [89 N]
Max Moment M_x	60 in/lb [6.7 Nm]	15 in/lb [1.6 Nm]
Max Moment M_y	60 in/lb [6.7 Nm]	20 in/lb [2.2 Nm]
Max Moment M_z	60 in/lb [6.7 Nm]	15 in/lb [1.6 Nm]

Material: High Strength, Hard Coated aluminum bronze alloys, Steel

Weight: 2 oz [56 g]

Piston Diameter: .625 in [15.8 mm]

HOLDING FORCES CHART

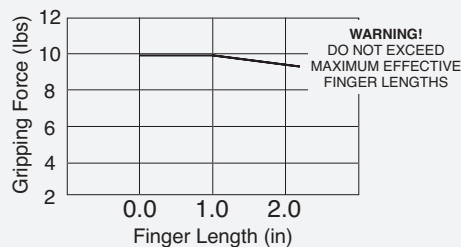

WARNING! Do not exceed tooling jaw length. See Chart above.

LOADING INFORMATION

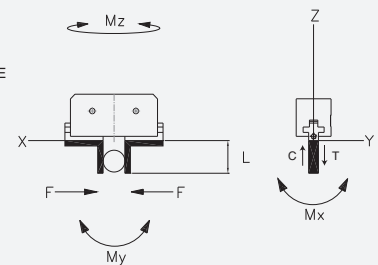

LOOK! More Technical specifications for sensors on "Sensors Accessories" page.

HOW TO ORDER

When ordering, please specify: Design/Model Number and Options.

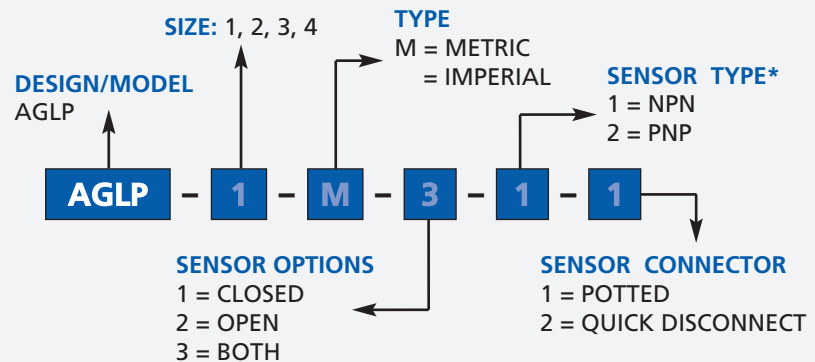

* NOTE: Hall Effect 4mm dia., 5-24 VDC, 22 mA and comes with 2 meter cable or quick disc.

Sensor Part # SHN01, SHN03, SHP01, SHP03

January 2009 - PATENTED Made in the USA

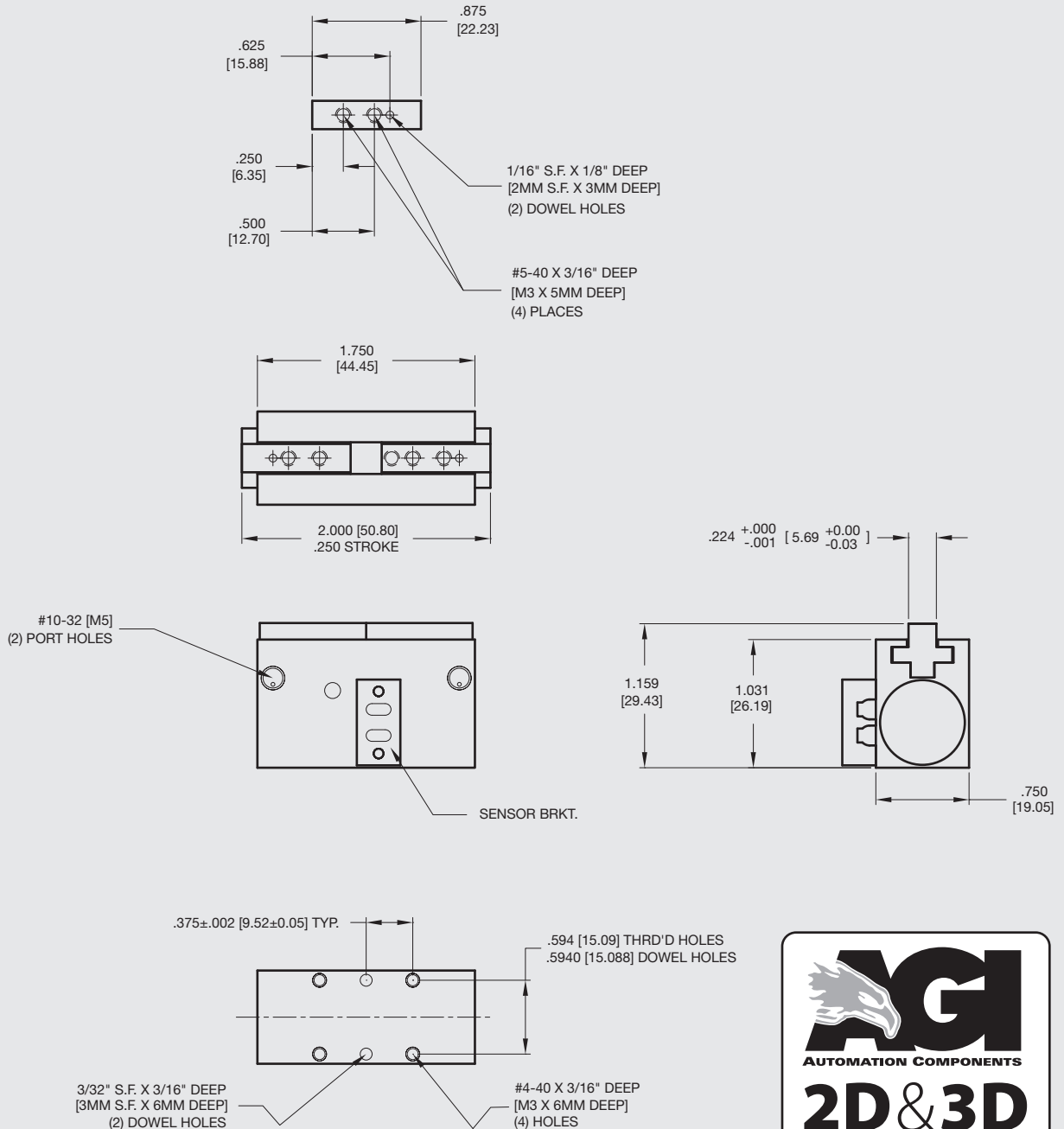

Unless noted, all tolerances are as indicated here:



All Dowel Holes are SF (Slip Fit) Locational Tolerance ± .0005" [0.13mm]



Metric Threads Course Pitch

Imperial:
Inch 0.00 = ±.01
0.000 = ±.005
0.0000 = ±.0005

Metric: [0.] = ±.25
[mm] [0.0] = ±.13
[0.00] = ±.013



AGLP-2 Parallel Gripper

T-Slot Bearing Series, Low Profile

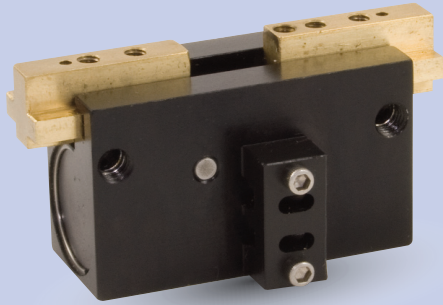

FEATURES AND BENEFITS

- Jaws are T-Slot bearing supported to prevent jaw breakage and offer superior load bearing performance.
- Rugged rack and pinion synchronizing.
- High gripping force to weight ratio.
- Compact design with long stroke.
- True parallel jaw motion for easy tooling.
- Units are permanently lubricated for non-lube air operation, allowing for compliance with OSHA regulations.
- Hall effect sensors are available to monitor open and closed position of the jaws.
- AGLP is fully field repairable for cost savings and minimum down time

SPECIFICATIONS

Design: Parallel, Double Acting, Synchronized Jaws

Stroke: 0.50 in [12.7 mm]

Gripping Force @ 80 PSI [5.5 BAR]

Closing: 10 lbs [44 N]
 Opening: 10 lbs [44 N]

Time:

Close: 0.12 sec [0.12 sec]
 Open: 0.12 sec [0.12 sec]

Pressure Range:

Low/High 10-100 PSI [.7-7 BAR]

Temperature Range:

Low/High -20°/180°F [-28°/80°C]

Side Play: ± 0.001 [.03 mm]

Loading Capacity:

	Static	Dynamic
Max Tensile T	65 lbs [289 N]	20 lbs [89 N]
Max Compressive C	65 lbs [289 N]	20 lbs [89 N]

Max Moment M_x 60 in/lb [6.7 Nm] 15 in/lb [1.6 Nm]

Max Moment M_y 60 in/lb [6.7 Nm] 20 in/lb [2.2 Nm]

Max Moment M_z 60 in/lb [6.7 Nm] 15 in/lb [1.6 Nm]

Max Moment M_z 60 in/lb [6.7 Nm] 15 in/lb [1.6 Nm]

Material: High Strength, Hard Coated aluminum bronze alloys, Steel

Weight: 2 oz [56 g]

Piston Diameter: .625 in [15.8 mm]

January 2009 - PATENTED Made in the USA

HOLDING FORCES CHART

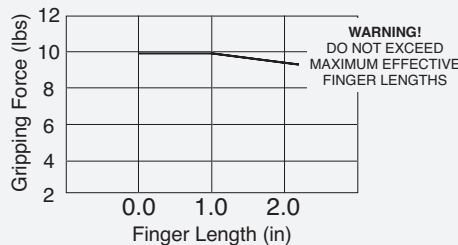

WARNING! Do not exceed tooling jaw length. See Chart above.

LOADING INFORMATION

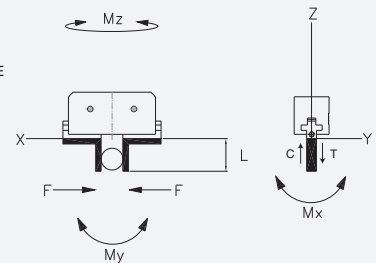

LOOK! More Technical specifications for sensors on "Sensors Accessories" page.

HOW TO ORDER

When ordering, please specify:
 Design/Model Number and Options.

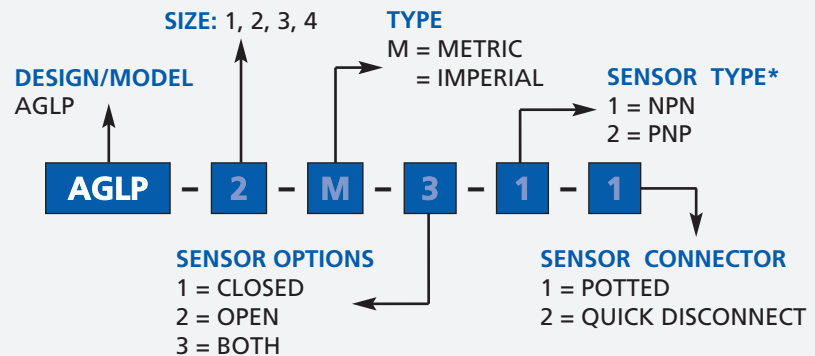

* NOTE: Hall Effect 4mm dia., 5-24 VDC, 22 mA and comes with 2 meter cable or quick disc.

Sensor Part # SHN01, SHNQ3, SHP01, SHPQ3

AGLP-2 Parallel Gripper

T-Slot Bearing Series, Low Profile

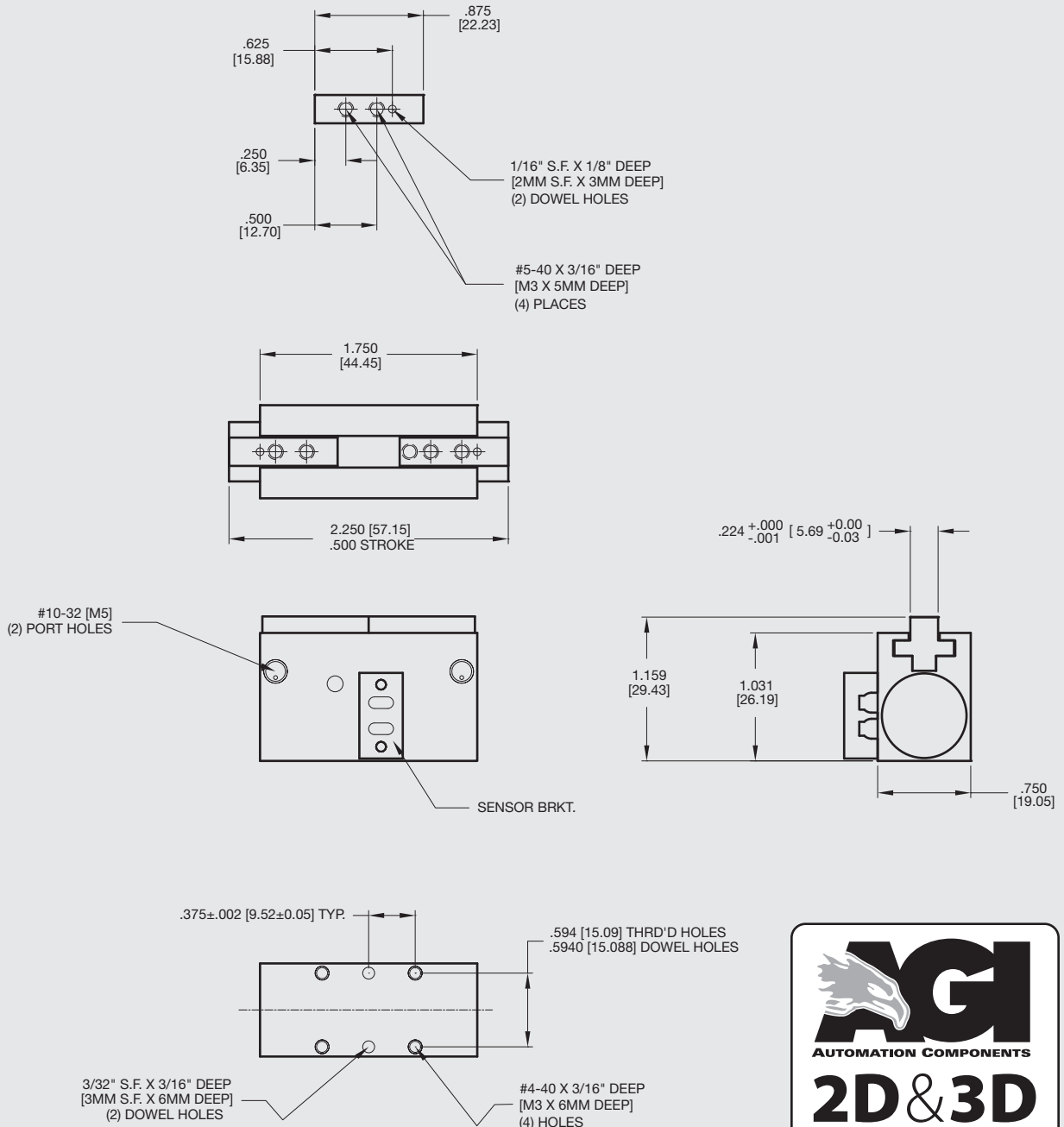

Unless noted, all tolerances are as indicated here:



All Dowel Holes are SF (Slip Fit) Locational Tolerance ± .0005" [0.13mm]



Metric Threads Course Pitch

Imperial:
Inch 0.00 = ±.01
0.000 = ±.005
0.0000 = ±.0005

Metric: [0.] = ±.25
[mm] [0.0] = ±.13
[0.00] = ±.013

AGLP-3 Parallel Gripper

T-Slot Bearing Series, Low Profile

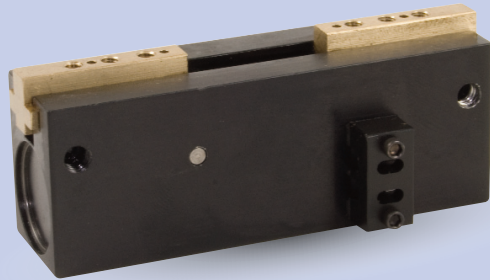

FEATURES AND BENEFITS

- Jaws are T-Slot bearing supported to prevent jaw breakage and offer superior load bearing performance.
- Rugged rack and pinion synchronizing.
- High gripping force to weight ratio.
- Compact design with long stroke.
- True parallel jaw motion for easy tooling.
- Units are permanently lubricated for non-lube air operation, allowing for compliance with OSHA regulations.
- Hall effect sensors are available to monitor open and closed position of the jaws.
- AGLP is fully field repairable for cost savings and minimum down time.

SPECIFICATIONS

Design: Parallel, Double Acting, Synchronized Jaws

Stroke: 0.75 in [19 mm]

Gripping Force @ 80 PSI [5.5 BAR]

Closing: 14 lbs [62 N]
Opening: 14 lbs [62 N]

Time:

Close: 0.12 sec [0.12 sec]
Open: 0.12 sec [0.12 sec]

Pressure Range:

Low/High 10-100 PSI [.7-7 BAR]

Temperature Range:

Low/High -20°/180°F [-28°/80°C]

Side Play: ± 0.001 [.03 mm]

Loading Capacity:

	Static	Dynamic
Max Tensile T	120 lbs [533 N]	40 lbs [177 N]
Max Compressive C	120 lbs [533 N]	40 lbs [177 N]
Max Moment M_x	75 in/lb [8.5 Nm]	25 in/lb [2.8 Nm]
Max Moment M_y	100 in/lb [11.3 Nm]	35 in/lb [3.9 Nm]
Max Moment M_z	75 in/lb [8.5 Nm]	25 in/lb [2.8 Nm]

Material: High Strength, Hard Coated aluminum bronze alloys, Steel

Weight: 5 oz [142 g]

Piston Diameter: 0.700 in [17.7 mm]

January 2009 - PATENTED Made in the USA

HOLDING FORCES CHART

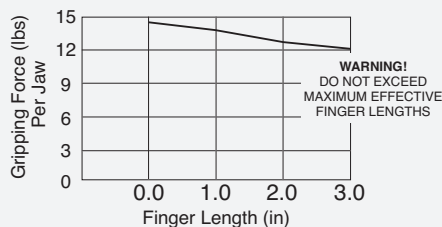

WARNING! Do not exceed tooling jaw length. See Chart above.

LOADING INFORMATION

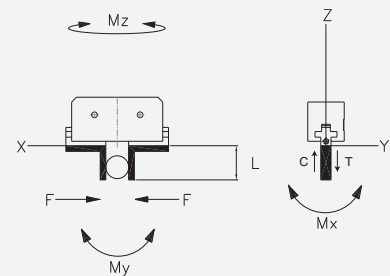

LOOK! More Technical specifications for sensors on "Sensors Accessories" page.

HOW TO ORDER

When ordering, please specify: Design/Model Number and Options.

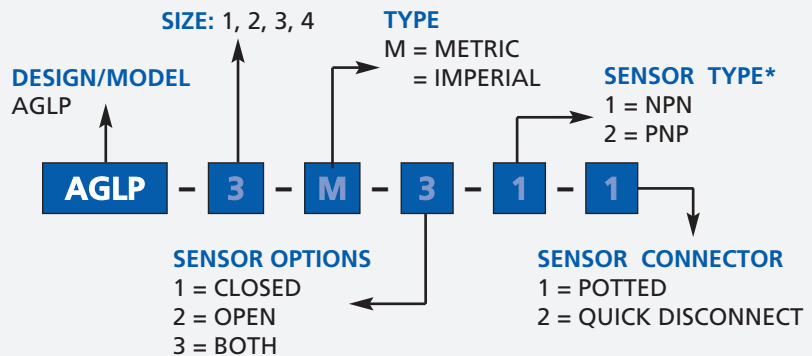

* NOTE: Hall Effect 4mm dia., 5-24 VDC, 22 mA and comes with 2 meter cable or quick disc.

Sensor Part # SHN01, SHNQ3, SHP01, SHPQ3

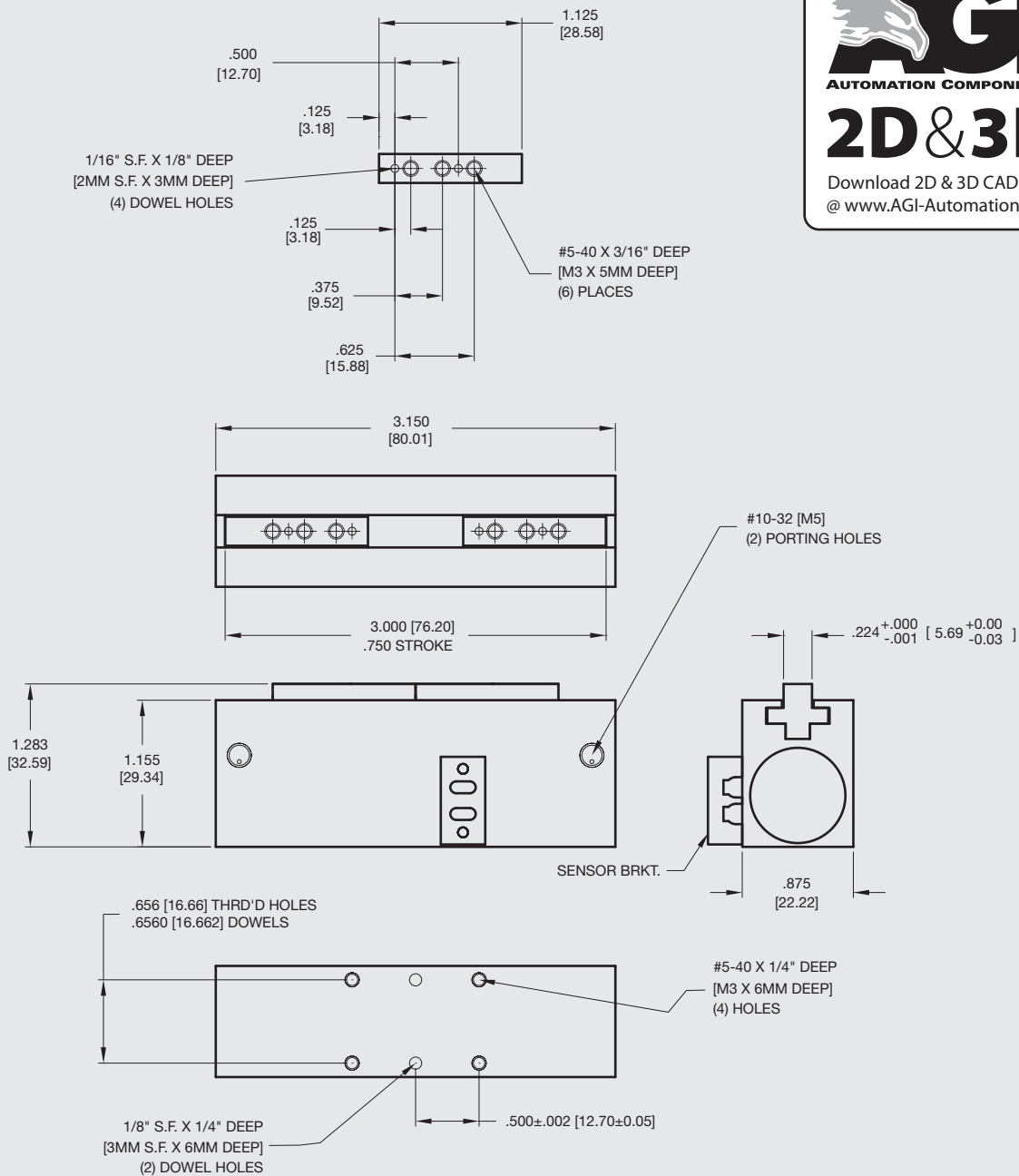

Unless noted, all tolerances are as indicated here:



All Dowel Holes are SF (Slip Fit) Locational Tolerance ± .0005" [0.013mm]



Metric Threads Course Pitch

Imperial:
Inch

0.00 = ±.01
0.000 = ±.005
0.0000 = ±.0005

Metric:
[mm]
[0.] = ±.25
[0.0] = ±.13
[0.00] = ±.013

AGLP-4 Parallel Gripper

T-Slot Bearing Series, Low Profile

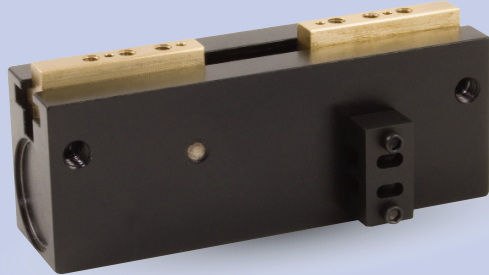

FEATURES AND BENEFITS

- Jaws are T-Slot bearing supported to prevent jaw breakage and offer superior load bearing performance.
- Rugged rack and pinion synchronizing.
- High gripping force to weight ratio.
- Compact design with long stroke.
- True parallel jaw motion for easy tooling.
- Units are permanently lubricated for non-lube air operation, allowing for compliance with OSHA regulations.
- Hall effect sensors are available to monitor open and closed position of the jaws.
- AGLP is fully field repairable for cost savings and minimum down time

SPECIFICATIONS

Design: Parallel, Double Acting, Synchronized Jaws

Stroke: 1.00 in [25.4 mm]

Gripping Force @ 80 PSI [5.5 BAR]

Closing: 14 lbs [62 N]
Opening: 14 lbs [62 N]

Time:

Close: 0.12 sec [0.12 sec]
Open: 0.12 sec [0.12 sec]

Pressure Range:

Low/High 10-120 PSI [.7-7 BAR]

Temperature Range:

Low/High -20°/180°F [-28°/80°C]

Side Play: ± 0.001 [.03 mm]

Loading Capacity:

	Static	Dynamic
Max Tensile T	120 lbs [533 N]	40 lbs [177 N]
Max Compressive C	120 lbs [533 N]	40 lbs [177 N]
Max Moment M_x	75 in/lb [8.5 Nm]	25 in/lb [2.8 Nm]
Max Moment M_y	100 in/lb [11.3 Nm]	35 in/lb [3.9 Nm]
Max Moment M_z	75 in/lb [8.5 Nm]	25 in/lb [2.8 Nm]

Material: High Strength, Hard Coated aluminum bronze alloys, Steel

Weight: 5 oz [142 g]

Piston Diameter: 0.700 in [17.7 mm]

HOLDING FORCES CHART

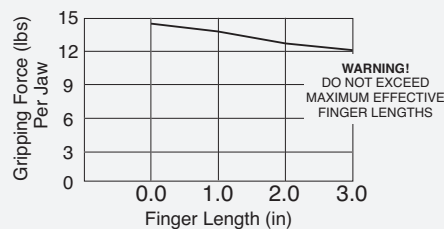

WARNING! Do not exceed tooling jaw length. See Chart above.

LOADING INFORMATION

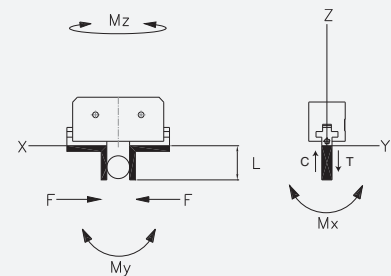

LOOK! More Technical specifications for sensors on "Sensors Accessories" page.

HOW TO ORDER

When ordering, please specify: Design/Model Number and Options.

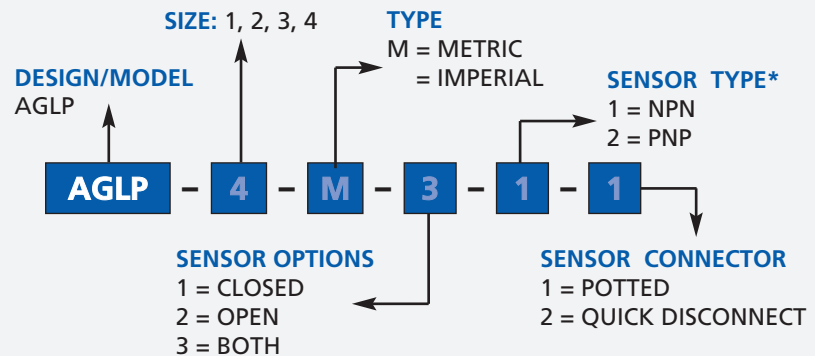

* NOTE: Hall Effect 4mm dia., 5-24 VDC, 22 mA and comes with 2 meter cable or quick disc.

Sensor Part # SHN01, SHNQ3, SHP01, SHPQ3

January 2009 - PATENTED Made in the USA

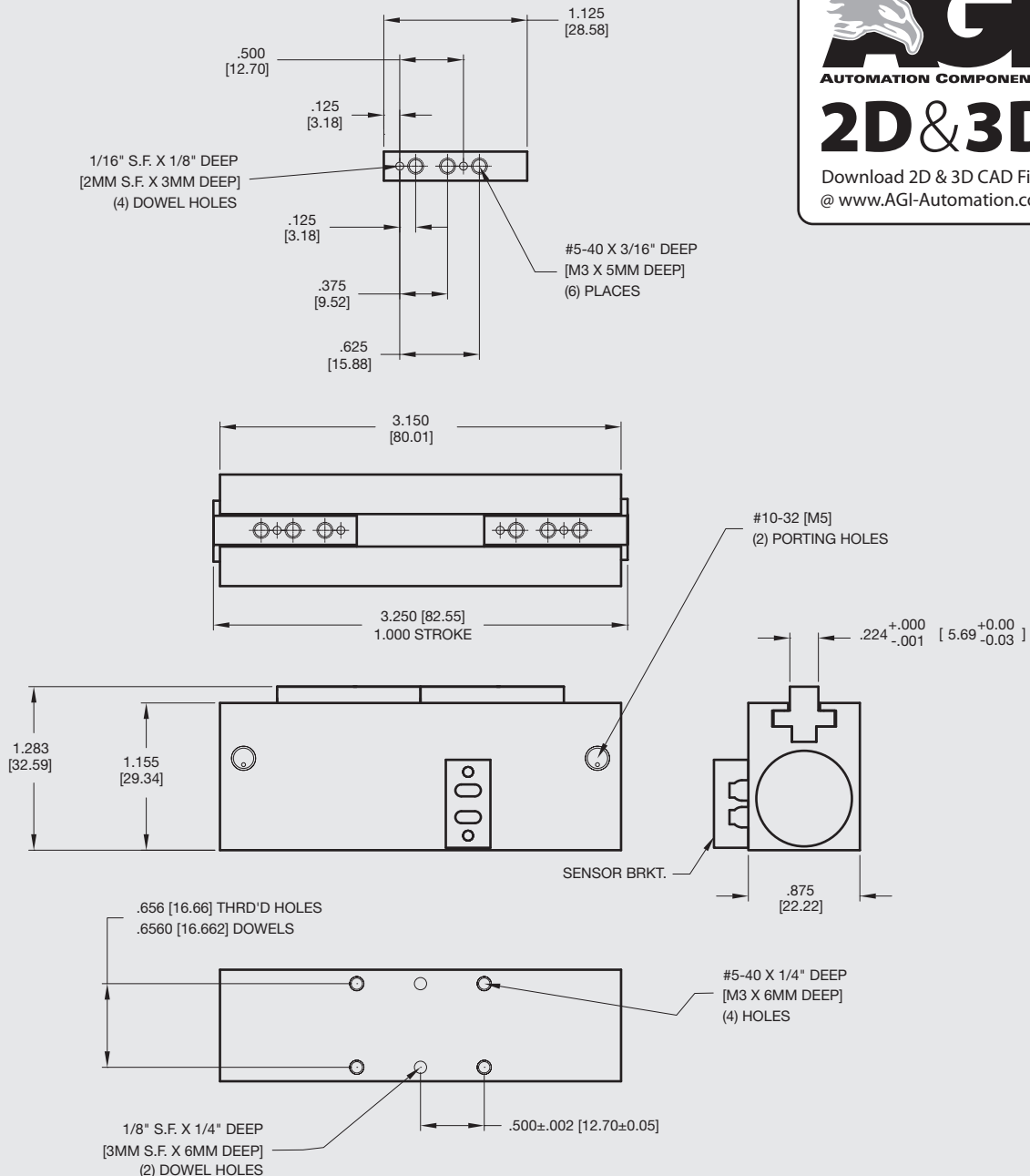

Unless noted, all tolerances are as indicated here:



All Dowel Holes are SF (Slip Fit) Locational Tolerance ± .0005" [0.13mm]



Metric Threads Course Pitch

Imperial:
0.00 = ±.01
0.000 = ±.005
0.0000 = ±.0005

Metric: [0.] = ±.25
[0.0] = ±.13
[0.00] = ±.013



AGP-187 Parallel Gripper

Double Guided Wedge

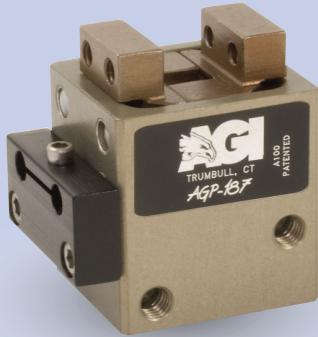

FEATURES AND BENEFITS

- Jaws machined from S7 tool steel to prevent jaw breakage.
- Ultra high gripping force to weight ratio.
- True parallel jaw motion for easy tooling.
- Units are permanently lubricated for non-lube air operation, this allowing for compliance with OSHA regulations.
- Additional side mounting holes and side air ports for optional mounting and porting available.
- Proximity switches are available to monitor open and closed position of the jaws.
- Fully field repairable for cost savings and minimum down time.

SPECIFICATIONS

Design: Parallel, Double Acting, Synchronized Jaws

Stroke: 0.16 in [4 mm]

Gripping Force @ 80 PSI [5.5 bar]:

Close: 15 lbs [66 N]

Opening: 16 lbs [71 N]

Time:

Close: 0.15 sec [0.15 sec]

Open: 0.15 sec [0.15 sec]

Pressure Range: 20-120 PSI [1.3-8 bar]

Temperature Range: -20°-180°F [-28°-80°C]

Side Play: ± 0.001 [0.03 mm]

Repeatability from center: ±.002 [0.06 mm]

Loading Capacity:

	Static	Dynamic
Max Tensile T	50 lbs [222 N]	7 lbs [31 N]

Max Compressive C	75 lbs [333 N]	12 lbs [53 N]
-------------------	----------------	---------------

Max Moment Mx	30 in/lb [3.4 Nm]	5 in/lb [0.6 Nm]
---------------	-------------------	------------------

Max Moment My	30 in/lb [3.4 Nm]	5 in/lb [0.6 Nm]
---------------	-------------------	------------------

Max Moment Mz	30 in/lb [3.4 Nm]	5 in/lb [0.6 Nm]
---------------	-------------------	------------------

Material:	High Strength, Hard Coated aluminum bronze alloys, Steel	
-----------	--	--

Weight:	3 oz. [85 g]	
---------	--------------	--

Piston Diameter:	0.75 in [19 mm]	
------------------	-----------------	--

January 2009 - PATENTED Made in the USA

HOLDING FORCES CHART

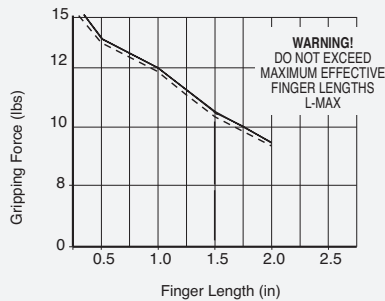

WARNING! Do not exceed tooling jaw length. See Chart above.

LOADING INFORMATION

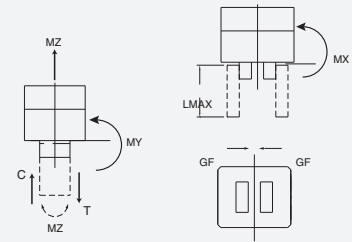

LOOK! More Technical specifications for sensors on "Sensors Accessories" page.

HOW TO ORDER

When ordering, please specify:
Design/Model Number and Options.

DESIGN/MODEL
AGP-250

TYPE
M = METRIC
= IMPERIAL

SENSOR TYPE*
1 = NPN
2 = PNP

AGP-187 - M - 3 - 1 - 1

SENSOR OPTIONS
1 = CLOSED
2 = OPEN
3 = BOTH

SENSOR CONNECTOR
1 = POTTED
2 = QUICK DISCONNECT
3 = QUICK DISCONNECT WITH RIGHT ANGLE

* NOTE: Proximity sensors are 4 mm dia., 12-30 VDC, 50 mA and comes with 2 meter cable or quick disc.

Sensor Part # SNC04, SNQ04, SPC04, SPQ04

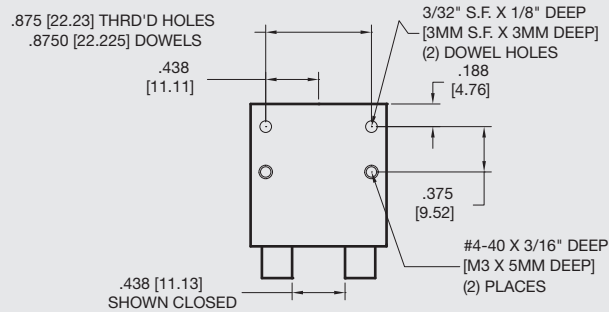
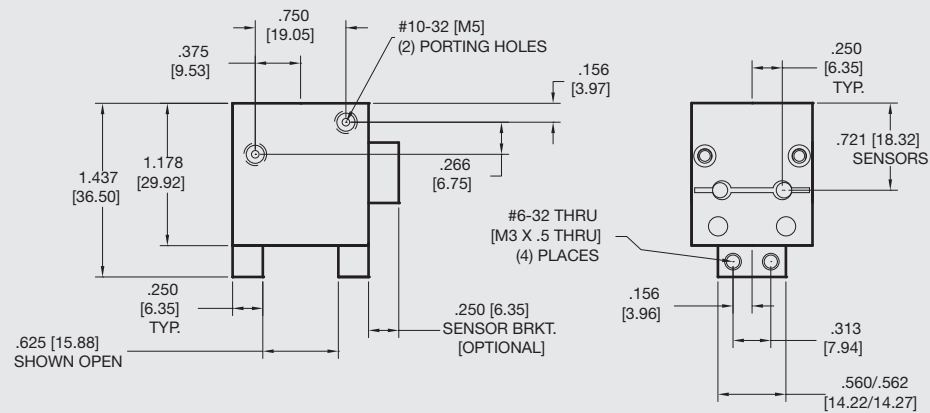
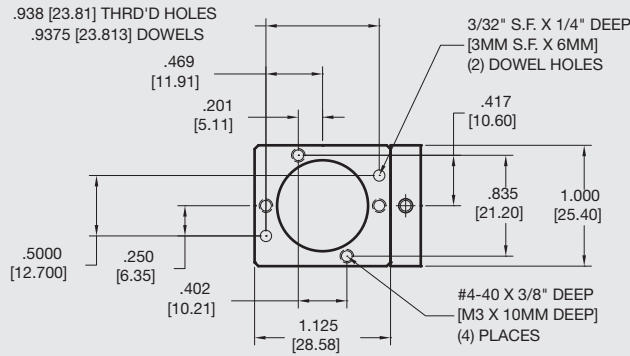

Unless noted, all tolerances are as indicated here:



All Dowel Holes are SF (Slip Fit) Locational Tolerance $\pm .0005"$ [0.13mm]



Metric Threads Course Pitch

Imperial:
Inch 0.00 = $\pm .01$
0.000 = $\pm .005$
0.0000 = $\pm .0005$

Metric: [0.] = $\pm .25$
[mm] [0.0] = $\pm .13$
[0.00] = $\pm .013$

AGP-250 Parallel Gripper

Double Guided Wedge



FEATURES AND BENEFITS

- Jaws machined from S7 tool steel to prevent jaw breakage.
- Ultra high gripping force to weight ratio.
- True parallel jaw motion for easy tooling.
- Units are permanently lubricated for non-lube air operation, this allowing for compliance with OSHA regulations.
- Additional side mounting holes and side air ports for optional mounting and porting available.
- Proximity switches are available to monitor open and closed position of the jaws.
- Fully field repairable for cost savings and minimum down time.

SPECIFICATIONS

Design: Parallel, Double Acting, Synchronized Jaws

Stroke: 0.25 in [6.3 mm]

Gripping Force @ 80 PSI [5.5 bar]:

Close: 20 lbs [89 N]

Opening: 22 lbs [97 N]

Time:

Close: 0.2 sec [0.2 sec]

Open: 0.2 sec [0.2 sec]

Pressure Range: 30-120 PSI [2-8 bar]

Temperature Range: -20°-180°F [-28°-80°C]

Side Play: ± 0.001 [0.03 mm]

Repeatability from center:
±.002 [0.06 mm]

Loading Capacity:

	Static	Dynamic
Max Tensile T	100 lbs [444 N]	15 lbs [66.7 N]
Max Compressive C	150 lbs [667 N]	25 lbs [111 N]

	90 in/lb [10 Nm]	15 in/lb [1.7 Nm]
Max Moment Mx	90 in/lb [10 Nm]	15 in/lb [1.7 Nm]
Max Moment My	90 in/lb [10 Nm]	15 in/lb [1.7 Nm]
Max Moment Mz	90 in/lb [10 Nm]	15 in/lb [1.7 Nm]

Material: High Strength, Hard Coated aluminum bronze alloys, Steel

Weight: 4 oz. [113 g]

Piston Diameter: 1.00 in [25.4 mm]

January 2009 - PATENTED Made in the USA

HOLDING FORCES CHART

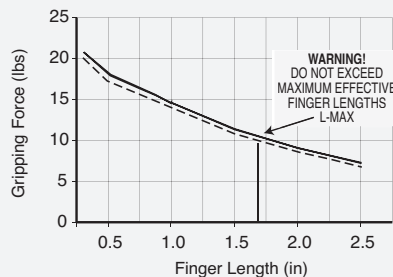

WARNING! Do not exceed tooling jaw length. See Chart above.

LOADING INFORMATION

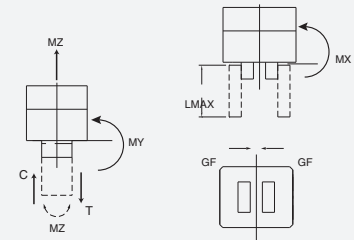

LOOK! More Technical specifications for sensors on "Sensors Accessories" page.

HOW TO ORDER

When ordering, please specify:
Design/Model Number and Options.

DESIGN/MODEL
AGP-250

TYPE
M = METRIC
= IMPERIAL

SENSOR TYPE*

1 = NPN
2 = PNP

OPTIONAL PORT

AGP-250 - **M** - **3** - **1** - **1** - **OP**

SENSOR OPTIONS

1 = CLOSED
2 = OPEN
3 = BOTH

SENSOR CONNECTOR

1 = POTTED
2 = QUICK DISCONNECT
3 = QUICK DISCONNECT WITH RIGHT ANGLE

* NOTE: Proximity sensors are 4 mm dia., 12-30 VDC, 50 mA and comes with 2 meter cable or quick disc.

Sensor Part # SNC04, SNQ04, SPC04, SPQ04

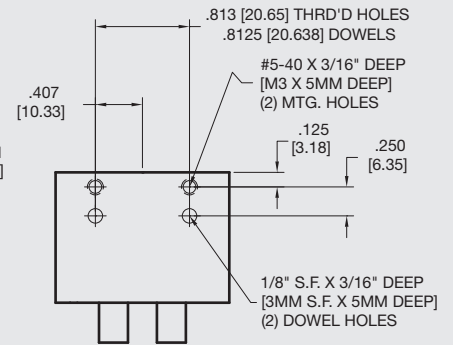
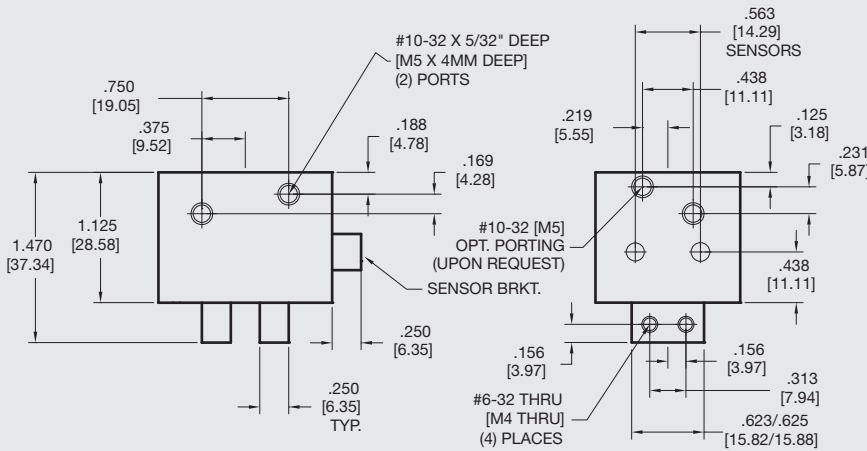
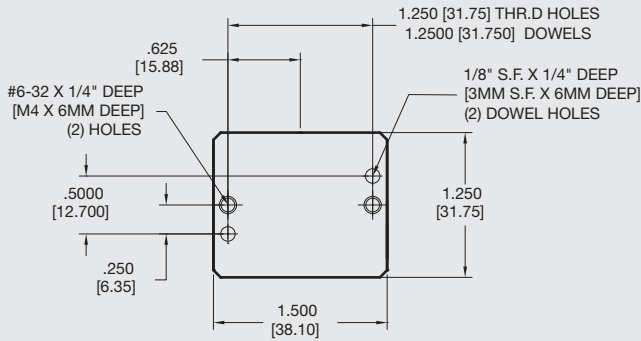

Unless noted, all tolerances are as indicated here:



All Dowel Holes are SF (Slip Fit) Locational Tolerance $\pm .0005"$ [0.13mm]



Metric Threads Course Pitch

Imperial:
Inch

0.00 = ± 0.1
0.000 = ± 0.005
0.0000 = ± 0.0005

Metric:
[mm] [0.] = ± 0.25
[0.0] = ± 0.13
[0.00] = ± 0.13



AGP-375 Parallel Gripper

Double Guided Wedge

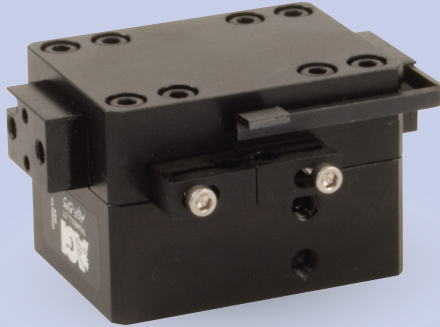

FEATURES AND BENEFITS

- Ultra high gripping force to weight ratio.
- True parallel jaw motion for easy tooling.
- Units are permanently lubricated for non-lube air operation, this allowing for compliance with OSHA regulations.
- Additional side mounting holes and side air ports for optional mounting and porting available.
- Proximity switches are available to monitor open and closed position of the jaws.
- Fully field repairable for cost savings and minimum down time.

SPECIFICATIONS

Design: Parallel, Double Acting, Synchronized Jaws

Stroke: 0.375 in [9.5 mm]

Gripping Force @ 80 PSI [5.5 bar]:

Closing: 20 lbs [89 N]

Opening: 22 lbs [97 N]

Time:

Close: 0.2 sec [0.2 sec]

Open: 0.2 sec [0.2 sec]

Pressure Range: 30-120 PSI [2-8 bar]

Temperature Range: -20°-180°F [-28°-80°C]

Side Play: ± 0.001 [0.03 mm]

Repeatability from center: ±.002 [0.06 mm]

Loading Capacity:

	Static	Dynamic
Max Tensile T	200 lbs [889 N]	25 lbs [111 N]
Max Compressive C	400 lbs [1780 N]	25 lbs [111 N]

Max Moment Mx 150 in/lb [17 Nm] 25 in/lb [2.8 Nm]

Max Moment My 150 in/lb [17 Nm] 25 in/lb [2.8 Nm]

Max Moment Mz 150 in/lb [17 Nm] 25 in/lb [2.8 Nm]

Max Moment Mz 150 in/lb [17 Nm] 25 in/lb [2.8 Nm]

Material: High Strength, Hard Coated aluminum bronze alloys, Steel

Weight: 7 oz. [198 g]

Piston Diameter: 1.00 in [25.4 mm]

January 2009 - PATENTED Made in the USA

HOLDING FORCES CHART

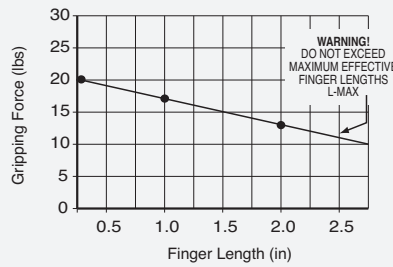

WARNING! Do not exceed tooling jaw length. See Chart above.

LOADING INFORMATION

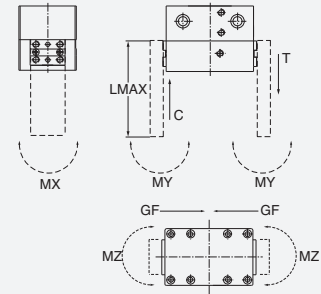

LOOK! More Technical specifications for sensors on "Sensors Accessories" page.

HOW TO ORDER

When ordering, please specify:
Design/Model Number and Options.

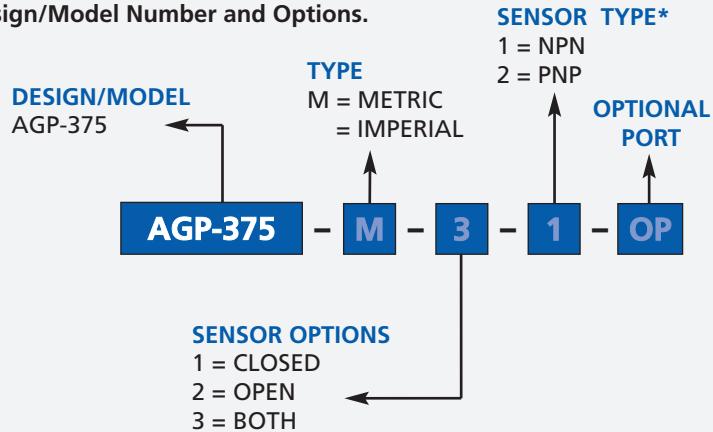

* NOTE: Proximity sensors are 4 mm dia., 12-30 VDC, 50 mA and comes with 2 meter cable or quick disc.

Sensor Part # SNC04, SPC04

AGP-375 Parallel Gripper

Double Guided Wedge

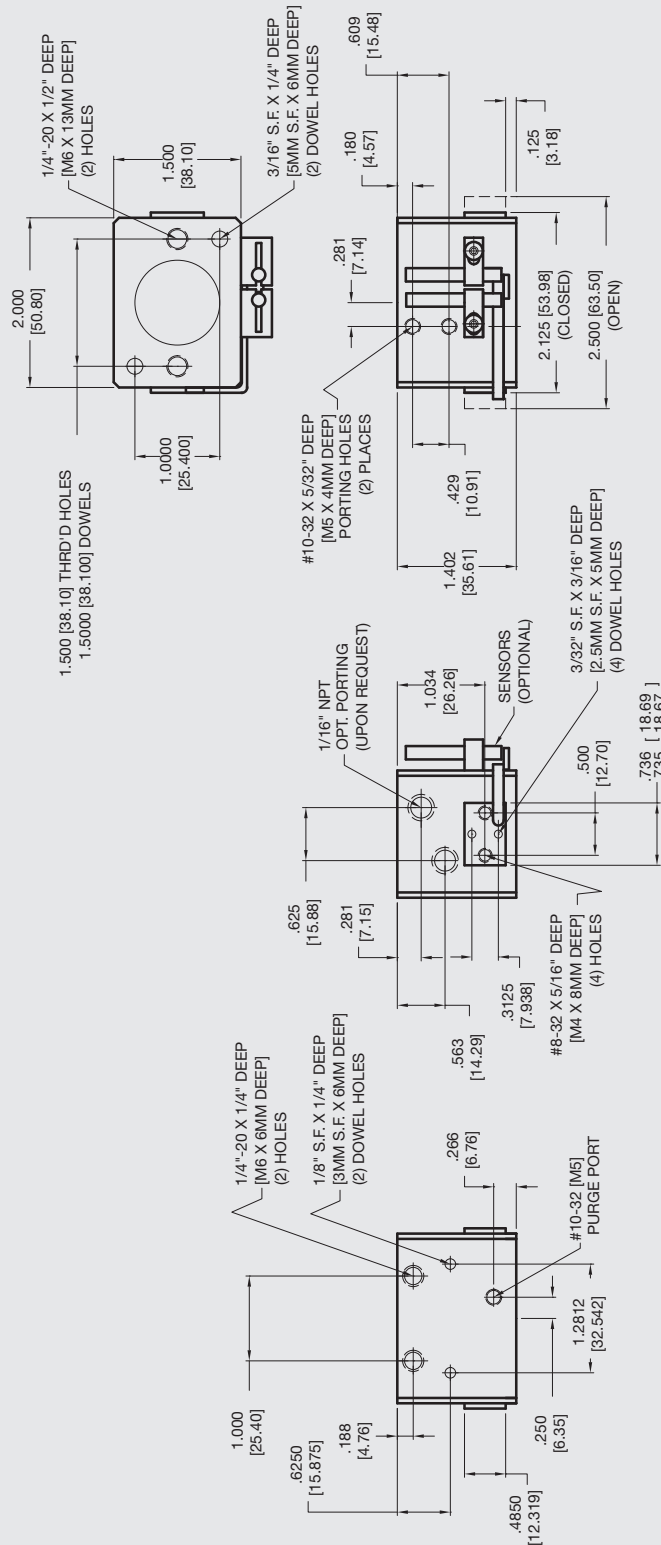

Unless noted, all tolerances are as indicated here:



All Dowel Holes are SF (Slip Fit) Locational Tolerance $\pm .0005$ " [0.13mm]



Metric Threads Course Pitch

Imperial:
 Inch 0.00 = $\pm .01$
 0.000 = $\pm .005$
 0.0000 = $\pm .0005$

Metric:
 [0.] = $\pm .25$
 [0.0] = $\pm .13$
 [0.00] = $\pm .013$



AGP-500 Parallel Gripper

Double Guided Wedge



FEATURES AND BENEFITS

- Ultra high gripping force to weight ratio.
- True parallel jaw motion for easy tooling.
- Totally sealed unit with air purge:
 - (i) can be slightly pressurized to prevent debris or coolant from entering.
 - (ii) a vacuum can be applied to evacuate any contaminants from inside the unit in a clean room environment.
- Units are permanently lubricated for non-lube air operation, this allowing for compliance with OSHA regulations.
 - Additional side mounting holes & air ports for optional mounting/porting are available.
- Proximity switches are available to monitor open/closed position of the jaws.
- Fully field repairable for cost savings and minimum down time.

SPECIFICATIONS

Design: Parallel, Double Acting, Synchronized Jaws

Stroke: 0.50 in [12.7 mm]

Gripping Force @ 80 PSI [5.5 bar]:

Close: 37 lbs [164 N]

Open: 40 lbs [178 N]

Time:

Close: 0.2 sec [0.2 sec]

Open: 0.2 sec [0.2 sec]

Pressure Range: 30-120 PSI [2-8 bar]

Temperature Range: -20°-180°F [-28°-80°C]

Side Play: ± 0.001 [0.03 mm]

Repeatability from center: ±.002 [0.06 mm]

Loading Capacity:

	Static	Dynamic
Max Tensile T	400 lbs [1780 N]	50 lbs [222 N]
Max Compressive C	750 lbs [3336 N]	50 lbs [222 N]

	Static	Dynamic
Max Moment Mx	300 in/lb [34 Nm]	50 in/lb [5.6 Nm]
Max Moment My	300 in/lb [34 Nm]	50 in/lb [5.6 Nm]
Max Moment Mz	300 in/lb [34 Nm]	50 in/lb [5.6 Nm]

	Static	Dynamic
Max Moment Mx	300 in/lb [34 Nm]	50 in/lb [5.6 Nm]
Max Moment My	300 in/lb [34 Nm]	50 in/lb [5.6 Nm]
Max Moment Mz	300 in/lb [34 Nm]	50 in/lb [5.6 Nm]

	Static	Dynamic
Max Moment Mx	300 in/lb [34 Nm]	50 in/lb [5.6 Nm]
Max Moment My	300 in/lb [34 Nm]	50 in/lb [5.6 Nm]
Max Moment Mz	300 in/lb [34 Nm]	50 in/lb [5.6 Nm]

	Static	Dynamic
Max Moment Mx	300 in/lb [34 Nm]	50 in/lb [5.6 Nm]
Max Moment My	300 in/lb [34 Nm]	50 in/lb [5.6 Nm]
Max Moment Mz	300 in/lb [34 Nm]	50 in/lb [5.6 Nm]

Material: High Strength, Hard Coated aluminum bronze alloys, Steel

Weight: 11 oz. [311 g]

Piston Diameter: 1.25 in [31.75 mm]

January 2009 - PATENTED Made in the USA

HOLDING FORCES CHART

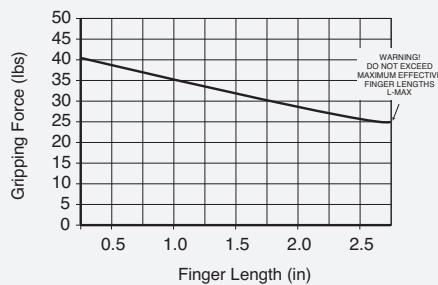

WARNING! Do not exceed tooling jaw length. See Chart above.

LOADING INFORMATION

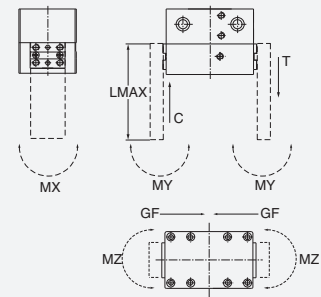

LOOK! More Technical specifications for sensors on "Sensors Accessories" page.

HOW TO ORDER

When ordering, please specify:
Design/Model Number and Options.

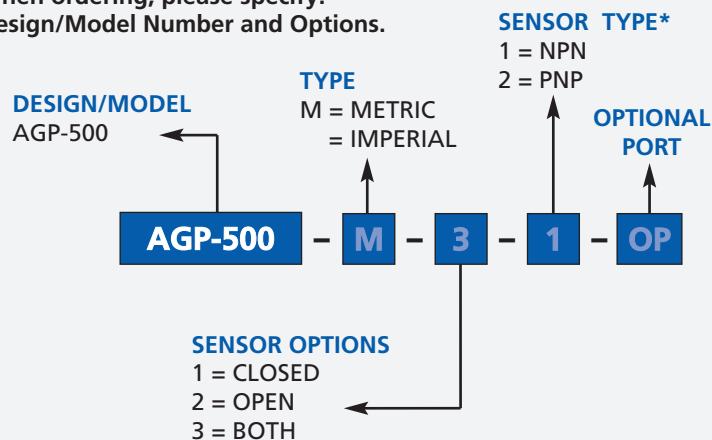

* NOTE: Proximity sensors are 4 mm dia., 12-30 VDC, 50 mA and comes with 2 meter cable or quick disc.

Sensor Part # SNC04, SPC04

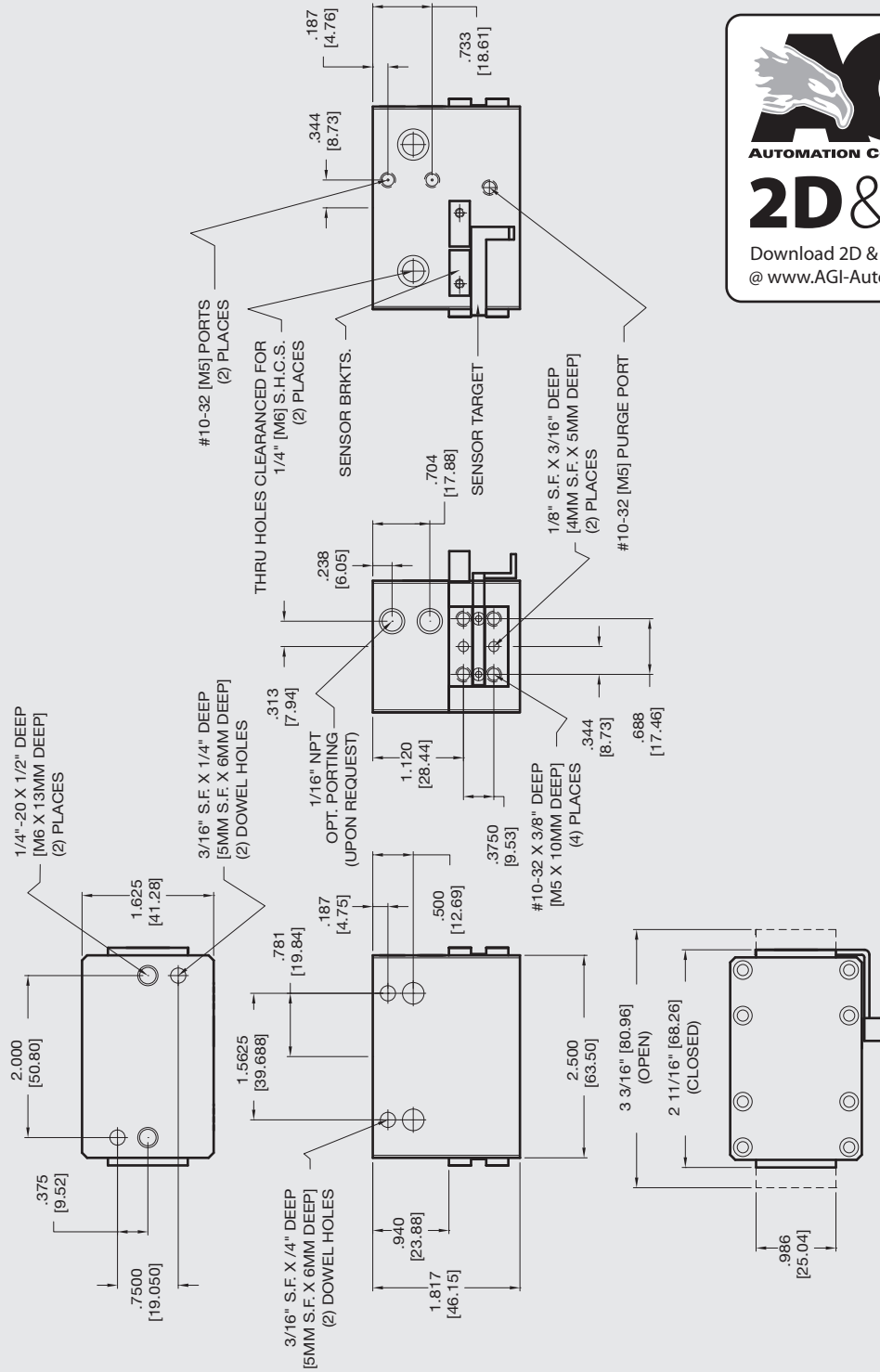

Unless noted, all tolerances are as indicated here:



All Dowel Holes are SF (Slip Fit) Locational Tolerance $\pm .0005"$ [0.13mm]



Metric Threads Course Pitch

Imperial:
Inch 0.00 = $\pm .01$
0.000 = $\pm .005$
0.0000 = $\pm .0005$

Metric: [0.] = $\pm .25$
[0.0] = $\pm .13$
[0.00] = $\pm .013$



AGPT-500 Parallel Gripper

T-Slot Bearing Series

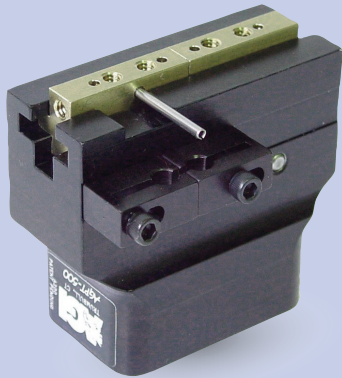

FEATURES AND BENEFITS

- Jaws are T-Slot bearing supported to prevent jaw breakage and offer superior load bearing performance.
- High gripping force to weight ratio.
- True parallel jaw motion for easy tooling.
- Units are permanently lubricated for non-lube air operation, allowing for compliance with OSHA regulations.
- Proximity switches are available to monitor open and closed position of the jaws.
- AGPT is fully field repairable for cost savings and minimum down time.
- Linkage is guided in the body for precise center repeatability.

SPECIFICATIONS

Design: Parallel, Double Acting, Synchronized Jaws

Stroke: 0.50 in [12.7 mm]

Gripping Force Per Jaw @ 80 PSI [5.5 BAR]

Closing: 10 PSI [44 N]

Opening: 12 PSI [53 N]

Time:

Close: 0.12 sec [0.12 sec]

Open: 0.12 sec [0.12 sec]

Pressure Range:

Low/High 10-120 PSI [7-8 BAR]

Temperature Range:

Low/High -20°/180°F [-28°/80°C]

Side Play: ± 0.001 [.03 mm]

Repeatability from Center: ± 0.002 [.06 mm]

Loading Capacity:

	Static	Dynamic
Max Tensile T	50 lbs [222 N]	15 lbs [66.7 N]
Max Compressive C	50 lbs [222 N]	15 lbs [66.7 N]

Max Moment M_x 50 in/lb [5.6 Nm] 12 in/lb [1.3 Nm]

Max Moment M_y 60 in/lb [6.7 Nm] 15 in/lb [1.7 Nm]

Max Moment M_z 50 in/lb [5.6 Nm] 12 in/lb [1.3 Nm]

Max Moment M_z 50 in/lb [5.6 Nm] 12 in/lb [1.3 Nm]

Material: High Strength, Hard Coated aluminum bronze alloys, Steel

Weight: 5 oz [142 g]

Piston Diameter: 0.625 in [15.8 mm]

January 2009 - PATENTED Made in the USA

HOLDING FORCES CHART

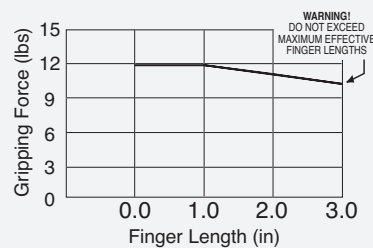

WARNING! Do not exceed tooling jaw length. See Chart above.

LOADING INFORMATION

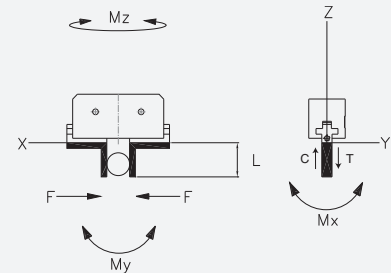

LOOK! More Technical specifications for sensors on "Sensors Accessories" page.

HOW TO ORDER

When ordering, please specify: Design/Model Number and Options.

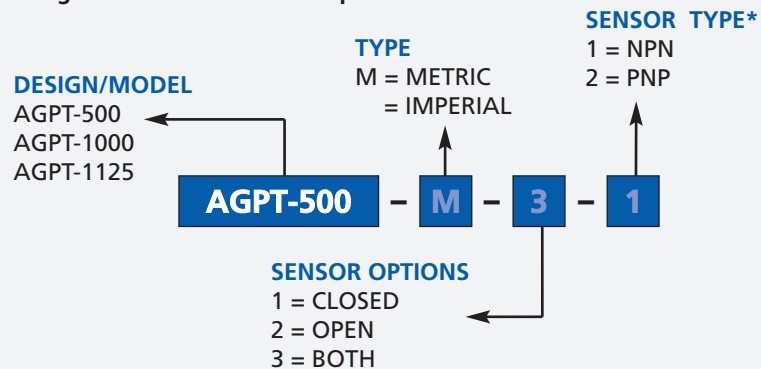

* NOTE: Proximity 4mm dia., 5-24 VDC, 22 mA and comes with 2 meter cable.

Sensor Part # SNC04, SPC04

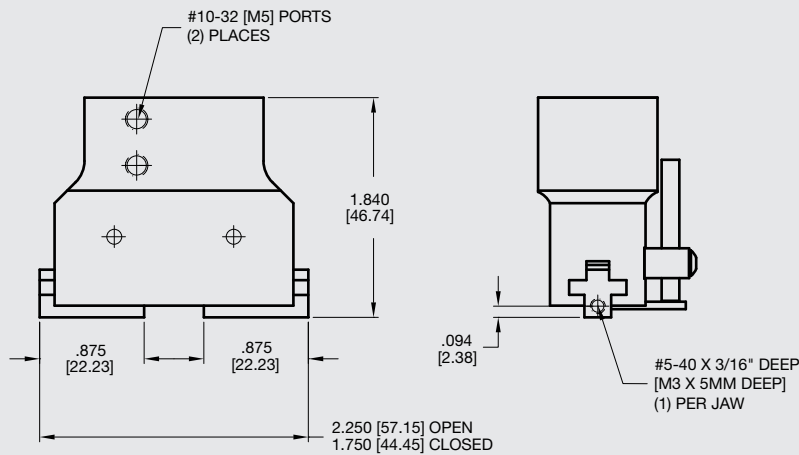
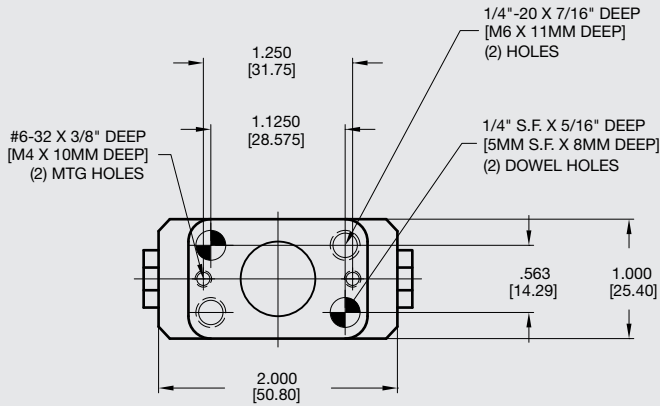

SENSORS (OPTIONAL)

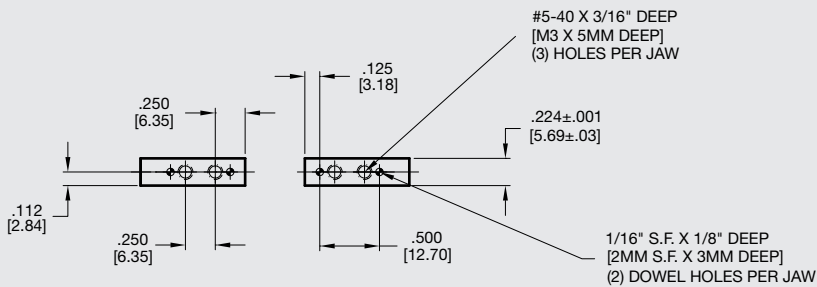
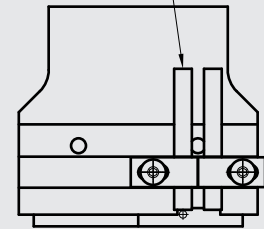

Unless noted, all tolerances are as indicated here:



All Dowel Holes are SF (Slip Fit) Locational Tolerance ± .0005" [0.013mm]



Metric Threads Course Pitch

Imperial: Inch

0.00 = ±.01
0.000 = ±.005
0.0000 = ±.0005

Metric: [0.] = ±.25
[0.0] = ±.13
[0.00] = ±.013

AGPT-1000 Parallel Gripper

T-Slot Bearing Series



FEATURES AND BENEFITS

- Jaws are T-Slot bearing supported to prevent jaw breakage and offer superior load bearing performance.
- High gripping force to weight ratio.
- True parallel jaw motion for easy tooling.
- Units are permanently lubricated for non-lube air operation, allowing for compliance with OSHA regulations.
- Proximity switches are available to monitor open and closed position of the jaws.
- AGPT is fully field repairable for cost savings and minimum down time.
- Linkage is guided in the body for precise center repeatability.

SPECIFICATIONS

Design: Parallel, Double Acting, Synchronized Jaws

Stroke: 1.0 in [25.4 mm]

Gripping Force Per Jaw @ 80 PSI [5.5 BAR]

Close: 15 PSI [67 N]

Opening: 17 PSI [75 N]

Time:

Close: 0.20 sec [0.20 sec]

Open: 0.20 sec [0.20 sec]

Pressure Range:

Low/High 10-120 PSI [7-8 BAR]

Temperature Range:

Low/High -20°/180°F [-28°/80°C]

Side Play:

± 0.001 [0.03 mm]

Repeatability

from Center: ± 0.001 [0.03 mm]

Loading Capacity:

	Static	Dynamic
Max Tensile T	60 lbs [266 N]	20 lbs [88.9 N]
Max Compressive C	60 lbs [266 N]	20 lbs [88.9 N]

Max Moment M_x 100 in/lb [11.3 Nm] 25 in/lb [2.8 Nm]

Max Moment M_y 120 in/lb [13.5 Nm] 30 in/lb [3.4 Nm]

Max Moment M_z 100 in/lb [11.3 Nm] 25 in/lb [2.8 Nm]

Material: High Strength, Hard Coated aluminum bronze alloys, Steel

Weight: 8 oz [226 g]

Piston Diameter: 0.75 in [19 mm]

January 2009 - PATENTED Made in the USA

HOLDING FORCES CHART

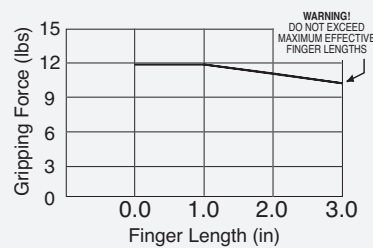

WARNING! Do not exceed tooling jaw length. See Chart above.

LOADING INFORMATION

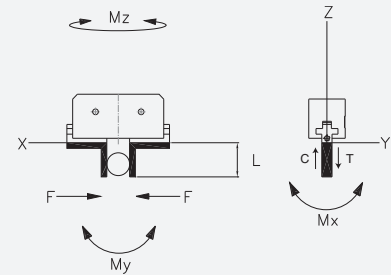

LOOK! More Technical specifications for sensors on "Sensors Accessories" page.

HOW TO ORDER

When ordering, please specify:
Design/Model Number and Options.

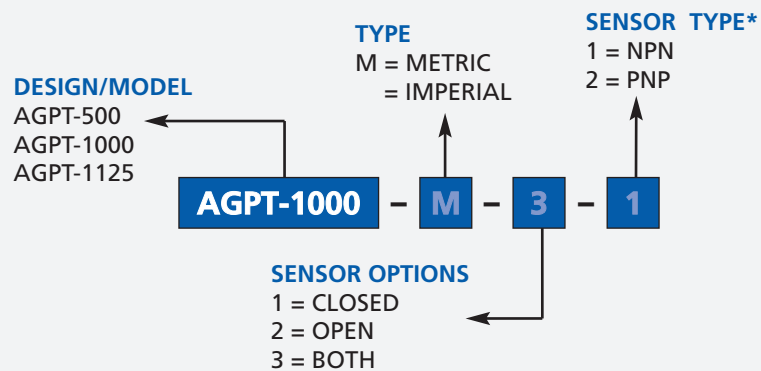

* NOTE: Proximity 4mm dia., 5-24 VDC, 22 mA and comes with 2 meter cable.

Sensor Part # SNC04, SPC04

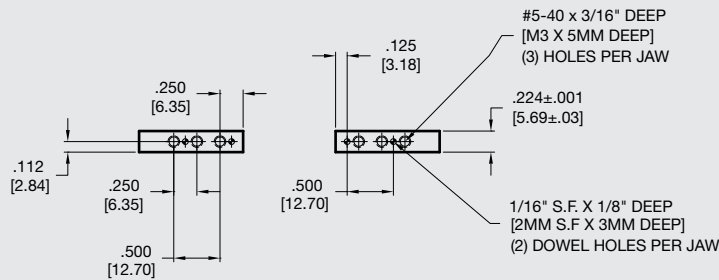
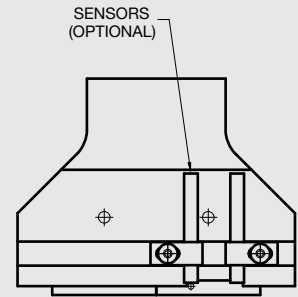
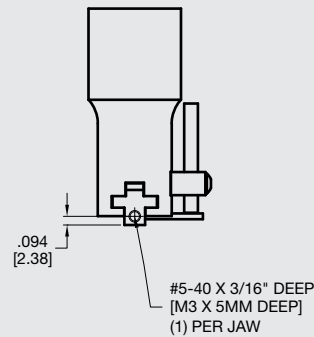
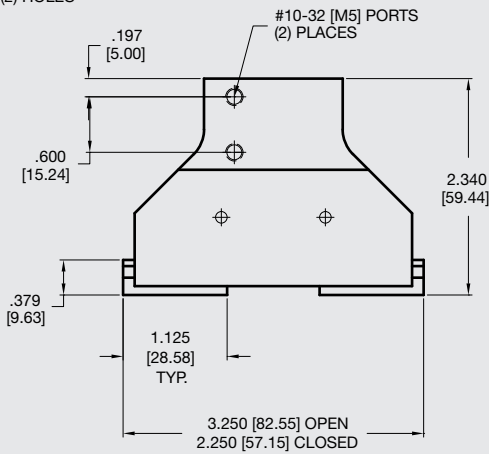
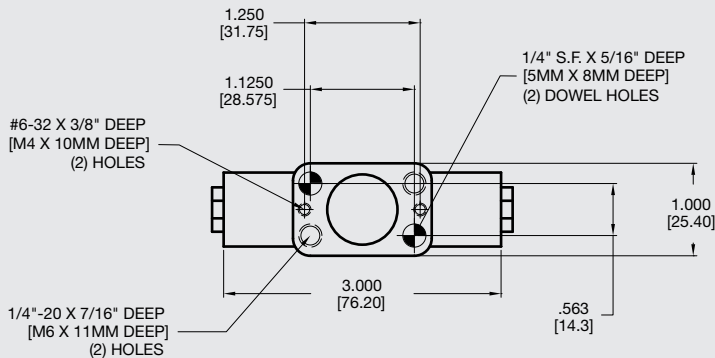

Unless noted, all tolerances are as indicated here:



All Dowel Holes are SF (Slip Fit) Locational Tolerance ± .0005" [.013mm]



Metric Threads Course Pitch

Imperial: Inch

0.00 = ±.01
0.000 = ±.005
0.0000 = ±.0005

Metric: [0.] = ±.25
[mm] [0.0] = ±.13
[0.00] = ±.013



AGPT-1125 Parallel Gripper

T-Slot Bearing Series

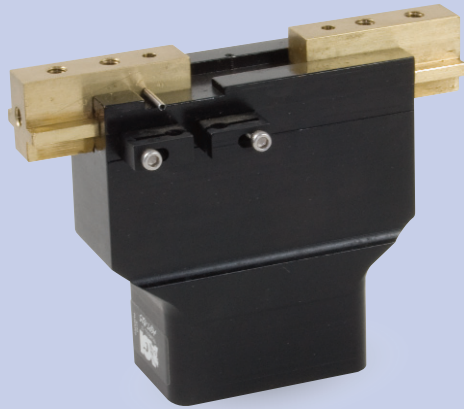

FEATURES AND BENEFITS

- Jaws are T-Slot bearing supported to prevent jaw breakage and offer superior load bearing performance.
- High gripping force to weight ratio.
- True parallel jaw motion for easy tooling.
- Units are permanently lubricated for non-lube air operation, allowing for compliance with OSHA regulations.
- Proximity switches are available to monitor open and closed position of the jaws.
- AGPT is fully field repairable for cost savings and minimum down time.
- Linkage is guided in the body for precise center repeatability.

SPECIFICATIONS

Design: Parallel, Double Acting, Synchronized Jaws

Stroke: 1.125 in [28.6 mm]

Gripping Force Per Jaw @ 80 PSI [5.5 BAR]

Closing: 30 PSI [133 N]

Opening: 27 PSI [120 N]

Time:

Close: 0.20 sec [0.20 sec]

Open: 0.20 sec [0.20 sec]

Pressure Range:

Low/High 10-120 PSI [7-8 BAR]

Temperature Range:

Low/High -20°/180°F [-28°/80°C]

Side Play:

± 0.001 [0.03 mm]

Repeatability from Center:

± 0.001 [0.03 mm]

Loading Capacity:

	Static	Dynamic
Max Tensile T	100 lbs [444 N]	30 lbs [133 N]
Max Compressive C	100 lbs [444 N]	30 lbs [133 N]
Max Moment M_x	200 in/lb [22.6 Nm]	25 in/lb [5.6 Nm]
Max Moment M_y	250 in/lb [28 Nm]	30 in/lb [6.7 Nm]
Max Moment M_z	200 in/lb [22.6 Nm]	25 in/lb [5.6 Nm]

Material: High Strength, Hard Coated aluminum bronze alloys, Steel

Weight: 1 lb. [0.5 kg]

Piston Diameter: 1.00 in [25.4 mm]

January 2009 - PATENTED Made in the USA

HOLDING FORCES CHART

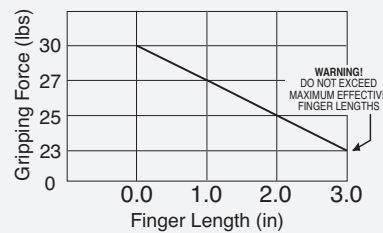

WARNING! Do not exceed tooling jaw length. See Chart above.

LOADING INFORMATION

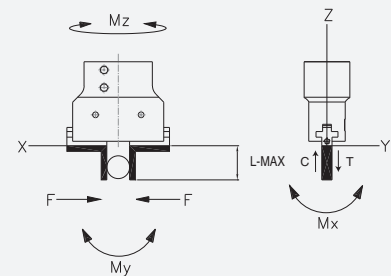

LOOK! More Technical specifications for sensors on "Sensors Accessories" page.

HOW TO ORDER

When ordering, please specify:
Design/Model Number and Options.

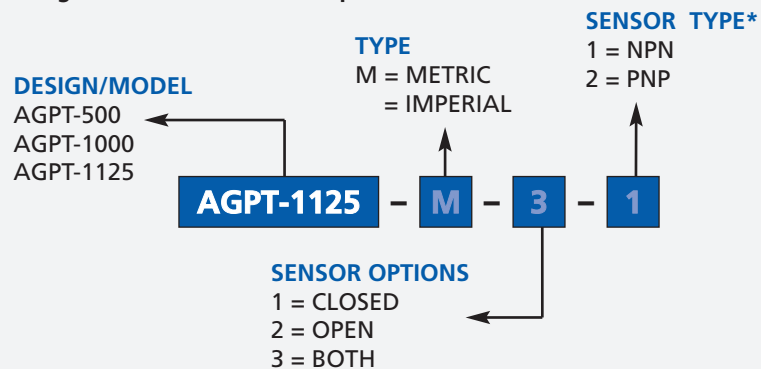

* NOTE: Proximity 4mm dia., 5-24 VDC, 22 mA and comes with 2 meter cable.

Sensor Part # SNC04, SPC04

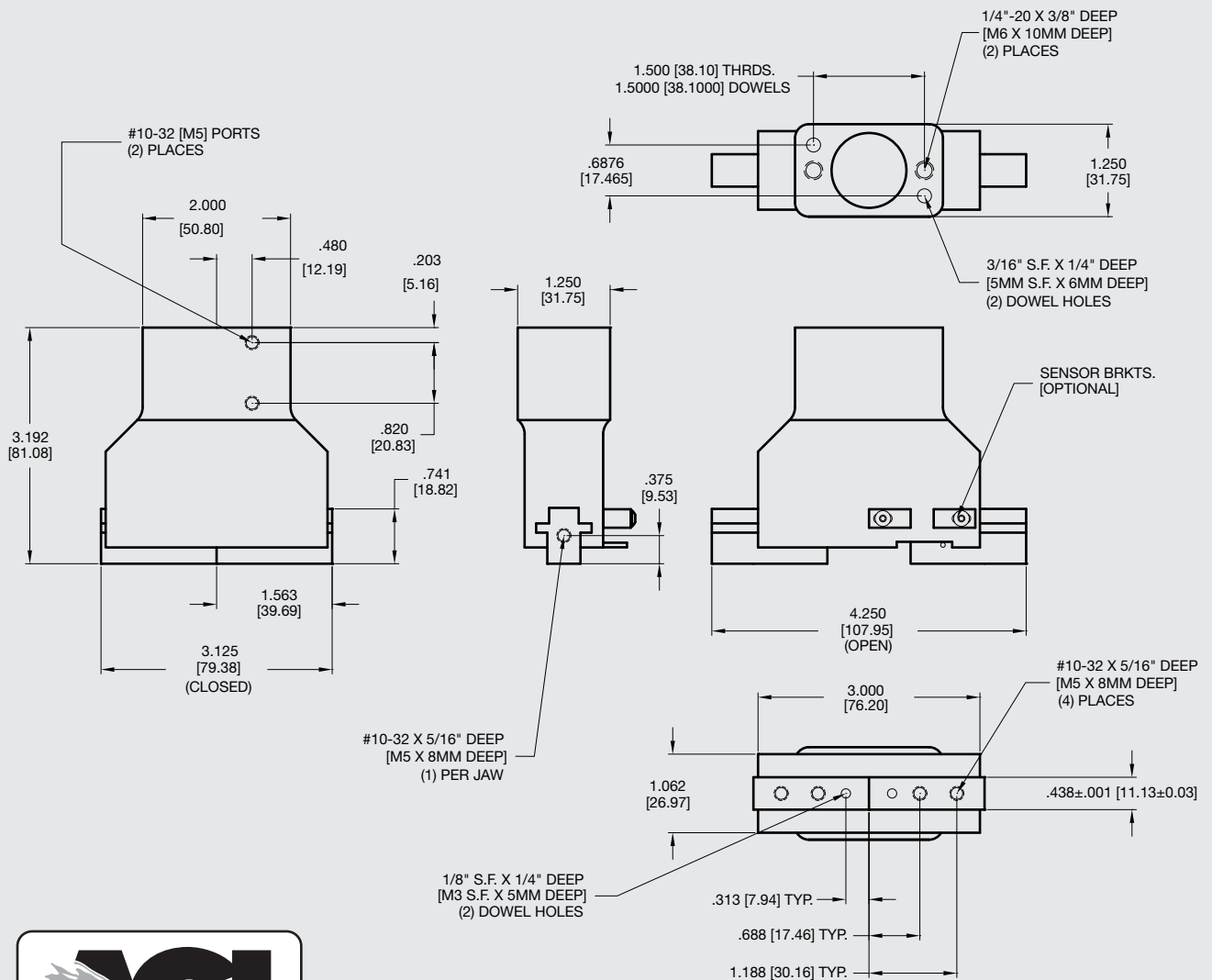

Unless noted, all tolerances are as indicated here:



All Dowel Holes are SF (Slip Fit) Locational Tolerance ± .0005" [0.13mm]



Metric Threads Course Pitch

Imperial:
Inch 0.00 = ±.01
0.000 = ±.005
0.0000 = ±.0005

Metric: [0.] = ±.25
[mm] [0.0] = ±.13
[0.00] = ±.013



AGW-250 Parallel Gripper

Wide-Body, Synchronous/Non-Synchronous

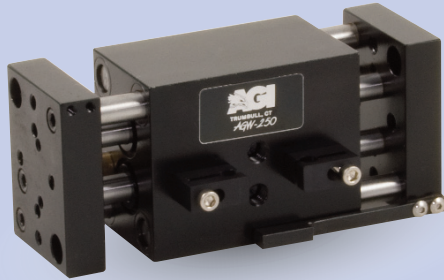

FEATURES AND BENEFITS

- Ultra high gripping force to weight ratio due to four opposing independent pistons that direct power to the jaws.
- True parallel jaw motion for easy tooling.
- Units are permanently lubricated for non-lube air operation, allowing for compliance with OSHA regulations.
- Large jaw support shafts are guided through the full width of the main body.
- Proximity switches are available to monitor open and closed position of the jaws.
- The AGW Series is fully field repairable for cost savings and minimum down time.
- Non-synchronous versions allow the gripper's jaws to comply to the part's centerline versus the gripper's centerline.

SPECIFICATIONS

Design: Parallel, Double Acting, Synchronized Jaws

Stroke: .75 in [19 mm]

Thrust Force @ 80 PSI [5.5 BAR]

Closing: 20 lbs [89 N]

Opening: 26 lbs [115 N]

Time:

Close: 0.2 sec [0.2 sec]

Open: 0.2 sec [0.2 sec]

Pressure Range:

Low/High 20-120 PSI [1.7-8 BAR]

Temperature Range:

Low/High -20°/180°F [-28°/80°C]

Side Play: ± 0.001 [.03 mm]

Repeatability

from Center: ± 0.002 [.06 mm]

Loading Capacity:

Static 50 lbs 10 lbs

[230 N] [44.5 N]

Dynamic 50 lbs 10 lbs

[230 N] [44.5 N]

Max Tensile T 100 in/lb 20 in/lb

[11.3 Nm] [2.3 Nm]

Max Moment M_x 150 in/lb 30 in/lb

[17 Nm] [3.4Nm]

Max Moment M_y 100 in/lb 20 in/lb

[11.3 Nm] [2.3 Nm]

Material: High Strength, Hard Coated

aluminum bronze alloys, Steel

Weight: 11 oz [311 g]

Piston Diameter: .500 in x 4 [12.7 mm]

January 2009 - PATENTED Made in the USA

HOLDING FORCES CHART

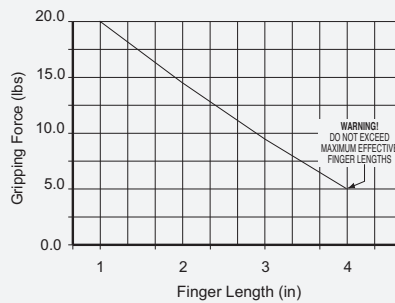

WARNING! Do not exceed tooling jaw length. See Chart above.

LOADING INFORMATION

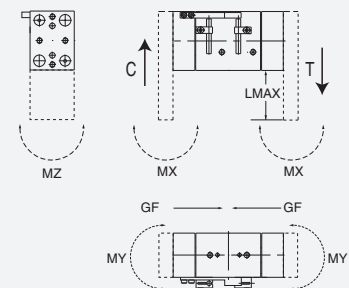

LOOK! More Technical specifications for sensors on "Sensors Accessories" page.

HOW TO ORDER

When ordering, please specify:
Design/Model Number and Options.

DESIGN/MODEL

- AGW-250
- AGW-375-1
- AGW-375-2
- AGW-375-4
- AGW-500-1
- AGW-500-2
- AGW-500-4
- AGW-625-2
- AGW-625-4
- AGW-625-6

SENSOR OPTIONS

- 1 = CLOSED
- 2 = OPEN
- 3 = BOTH

SENSOR TYPE*

- 1 = NPN
- 2 = PNP

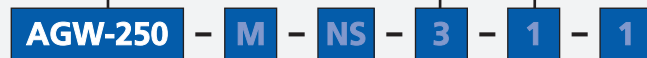

TYPE
M = METRIC
= IMPERIAL

NON-SYNCHRONIZED OPTION

SENSOR CONNECTOR

- 1 = POTTED
- 2 = QUICK DISCONNECT
- 3 = QUICK DISCONNECT WITH RIGHT ANGLE

* NOTE: Proximity 4mm dia., 5-24 VDC, 22 mA and comes with 2 meter cable.

Sensor Part # SNQ04, SNC04, SPC04, SPQ04

AGW-250 Parallel Gripper

Wide-Body, Synchronous/Non-Synchronous

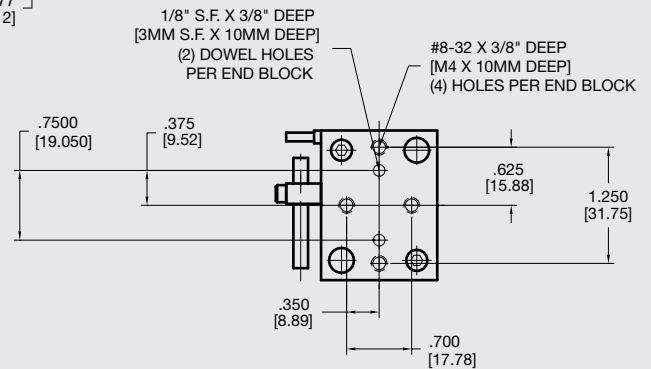
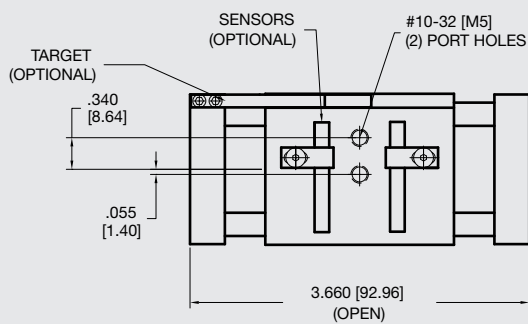
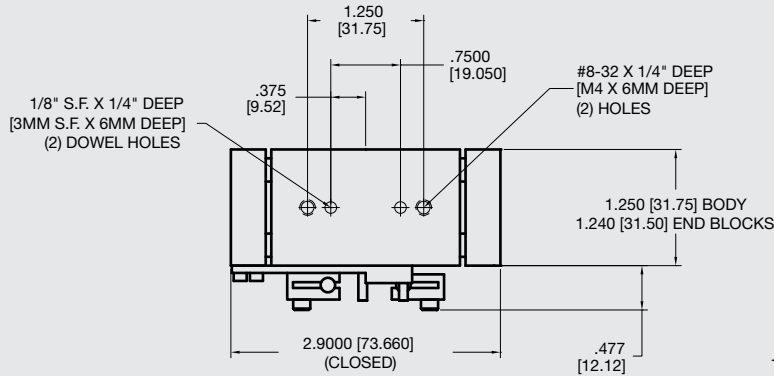
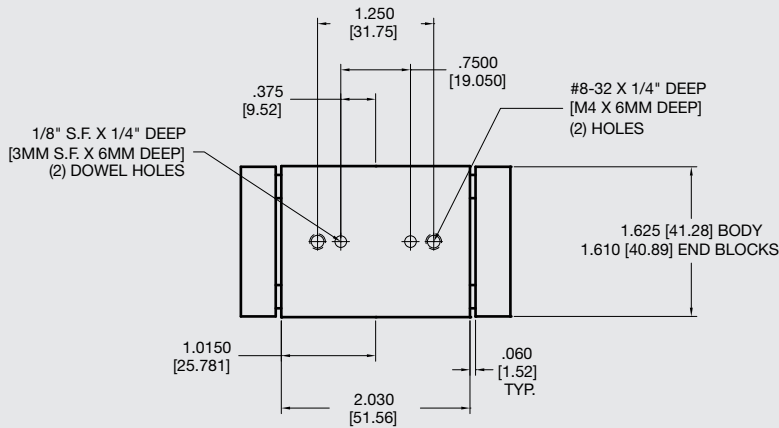

Unless noted, all tolerances are as indicated here:



All Dowel Holes are SF (Slip Fit) Locational Tolerance $\pm .0005$ " [0.13mm]



Metric Threads Course Pitch

Imperial: Inch

0.00 = ± 0.1
0.000 = ± 0.005
0.0000 = ± 0.0005

Metric: [0.] = ± 0.25
[0.0] = ± 0.13
[0.00] = ± 0.13



AGW-375-1 Parallel Gripper

Wide-Body, Synchronous/Non-Synchronous

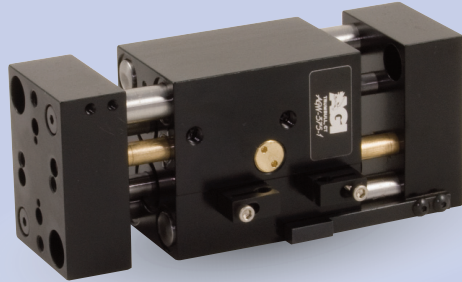

FEATURES AND BENEFITS

- Ultra high gripping force to weight ratio due to four opposing independent pistons that direct power to the jaws.
- True parallel jaw motion for easy tooling.
- Units are permanently lubricated for non-lube air operation, allowing for compliance with OSHA regulations.
- Large jaw support shafts are guided through the full width of the main body.
- Proximity switches are available to monitor open and closed position of the jaws.
- The AGW Series is fully field repairable for cost savings and minimum down time.
- Non-synchronous versions allow the gripper's jaws to comply to the part's centerline versus the gripper's centerline.

SPECIFICATIONS

Design: Parallel, Double Acting, Synchronized Jaws

Stroke: 1 in [25.4 mm]

Gripping Force @ 80 PSI Per Jaw [5.5 BAR]

Closing: 36 lbs [160 N]

Opening: 38 lbs [170 N]

Time:

Close: 0.3 sec [0.3 sec]

Open: 0.3 sec [0.3 sec]

Pressure Range:

Low/High 20-120 PSI [1.7-8 BAR]

Temperature Range:

Low/High -20°/180°F [-28°/80°C]

Side Play:

± 0.001 [.03 mm]

Repeatability from Center:

± 0.002 [.06 mm]

Loading Capacity:

	Static	Dynamic
Max Tensile T	100 lbs [445 N]	20 lbs [89 N]
Max Compressive C	100 lbs [445 N]	20 lbs [89 N]

Max Moment M_x 175 in/lb [18.7 Nm] 35 in/lb [4 Nm]

Max Moment M_y 250 in/lb [28 Nm] 50 in/lb [5.6Nm]

Max Moment M_z 175 in/lb [19.7 Nm] 35 in/lb [4 Nm]

Material: High Strength, Hard Coated aluminum bronze alloys, Steel

Weight: 1.3 lbs [6 kg]

Piston Diameter: .625 in x 4 [15.8 mm]

January 2009 - PATENTED Made in the USA

HOLDING FORCES CHART

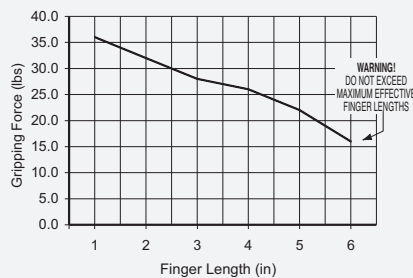

WARNING! Do not exceed tooling jaw length. See Chart above.

LOADING INFORMATION

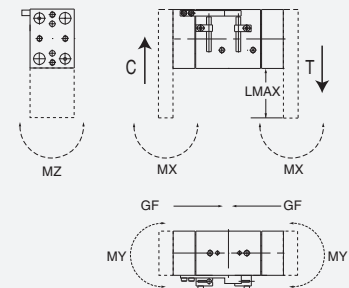

LOOK! More Technical specifications for sensors on "Sensors Accessories" page.

HOW TO ORDER

When ordering, please specify:
Design/Model Number and Options.

DESIGN/MODEL

- AGW-250
- AGW-375-1
- AGW-375-2
- AGW-375-4
- AGW-500-1
- AGW-500-2
- AGW-500-4
- AGW-625-2
- AGW-625-4
- AGW-625-6

SENSOR OPTIONS

- 1 = CLOSED
- 2 = OPEN
- 3 = BOTH

SENSOR TYPE*

- 1 = NPN
- 2 = PNP



TYPE
M = METRIC
= IMPERIAL

NON-SYNCHRONIZED OPTION

SENSOR CONNECTOR
1 = POTTED
2 = QUICK DISCONNECT
3 = QUICK DISCONNECT WITH RIGHT ANGLE

* NOTE: Proximity 4mm dia., 5-24 VDC, 22 mA and comes with 2 meter cable.

Sensor Part # SNQ04, SNC04, SPC04, SPQ04

AGW-375-1 Parallel Gripper

Wide-Body, Synchronous/Non-Synchronous

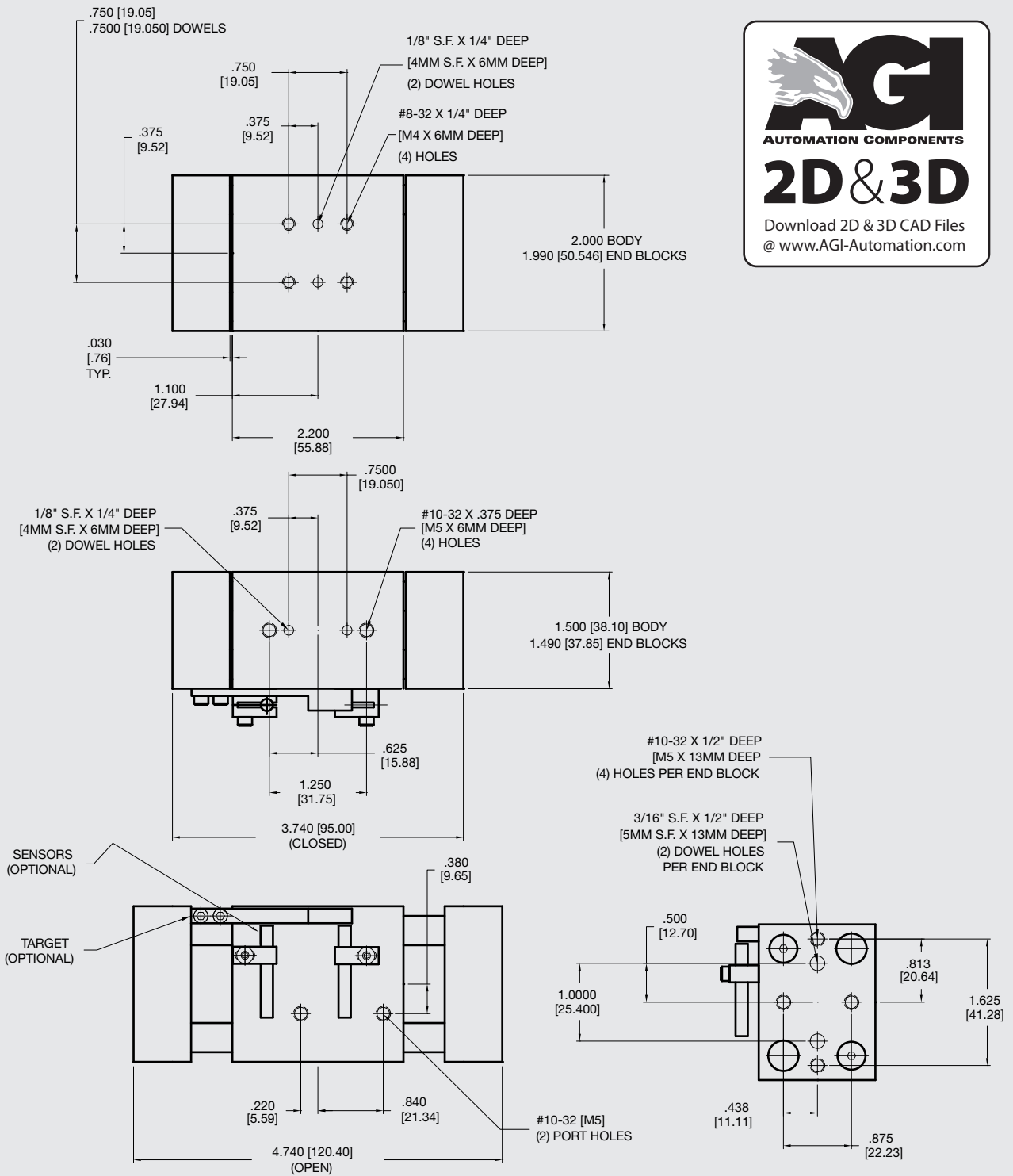

Unless noted, all tolerances are as indicated here:



All Dowel Holes are SF (Slip Fit) Locational Tolerance $\pm .0005"$ [0.13mm]



Metric Threads Course Pitch

Imperial:
Inch 0.00 = ± 0.01
0.000 = ± 0.005
0.0000 = ± 0.0005

Metric:
[0.] = ± 0.25
[mm] [0.0] = ± 0.13
[0.00] = ± 0.13



AGW-375-2 Parallel Gripper

Wide-Body, Synchronous/Non-Synchronous

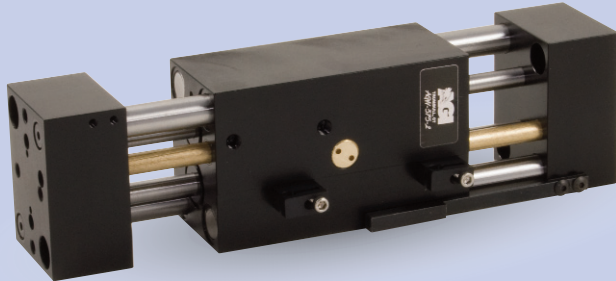

FEATURES AND BENEFITS

- Ultra high gripping force to weight ratio due to four opposing independent pistons that direct power to the jaws.
- True parallel jaw motion for easy tooling.
- Units are permanently lubricated for non-lube air operation, allowing for compliance with OSHA regulations.
- Large jaw support shafts are guided through the full width of the main body.
- Proximity switches are available to monitor open and closed position of the jaws.
- The AGW Series is fully field repairable for cost savings and minimum down time.
- Non-synchronous versions allow the gripper's jaws to comply to the part's centerline versus the gripper's centerline.

SPECIFICATIONS

Design: Parallel, Double Acting, Synchronized Jaws

Stroke: 2 in [50.8 mm]

Gripping Force @ 80 PSI Per Jaw [5.5 BAR]

Closing: 36 lbs [160 N]

Opening: 38 lbs [170 N]

Time:

Close: 0.3 sec [0.3 sec]

Open: 0.3 sec [0.3 sec]

Pressure Range:

Low/High 20-120 PSI [1.7-8 BAR]

Temperature Range:

Low/High -20°/180°F [-28°/80°C]

Side Play:

± 0.001 [.03 mm]

Repeatability from Center:

± 0.002 [.06 mm]

Loading Capacity:

	Static	Dynamic
Max Tensile T	100 lbs [445 N]	20 lbs [89 N]
Max Compressive C	100 lbs [445 N]	20 lbs [89 N]

Max Moment M_x 175 in/lb [19.5 Nm] 35 in/lb [4 Nm]

Max Moment M_y 250 in/lb [28 Nm] 50 in/lb [5.6 Nm]

Max Moment M_z 175 in/lb [19.5 Nm] 35 in/lb [4 Nm]

Material: High Strength, Hard Coated aluminum bronze alloys, Steel

Weight: 2 lbs [9 kg]

Piston Diameter: .625 in x 4 [15.8 mm]

January 2009 - PATENTED Made in the USA

HOLDING FORCES CHART

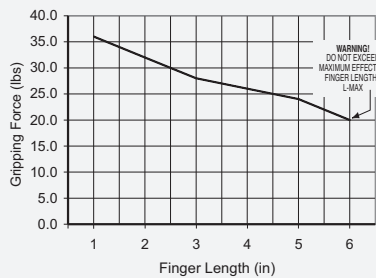

WARNING! Do not exceed tooling jaw length. See Chart above.

LOADING INFORMATION

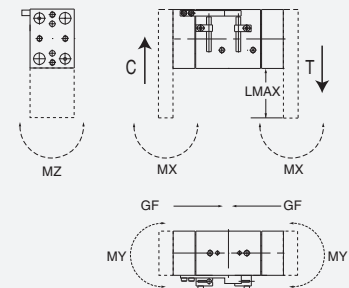

LOOK! More Technical specifications for sensors on "Sensors Accessories" page.

HOW TO ORDER

When ordering, please specify:
Design/Model Number and Options.

DESIGN/MODEL

- AGW-250
- AGW-375-1
- AGW-375-2
- AGW-375-4
- AGW-500-1
- AGW-500-2
- AGW-500-4
- AGW-625-2
- AGW-625-4
- AGW-625-6

SENSOR OPTIONS

- 1 = CLOSED
- 2 = OPEN
- 3 = BOTH

SENSOR TYPE*

- 1 = NPN
- 2 = PNP



TYPE
M = METRIC
= IMPERIAL

NON-SYNCHRONIZED OPTION

SENSOR CONNECTOR

- 1 = POTTED
- 2 = QUICK DISCONNECT
- 3 = QUICK DISCONNECT WITH RIGHT ANGLE

* NOTE: Proximity 4mm dia., 5-24 VDC, 22 mA and comes with 2 meter cable.

Sensor Part # SNQ04, SNC04, SPC04, SPQ04

AGW-375-2 Parallel Gripper

Wide-Body, Synchronous/Non-Synchronous

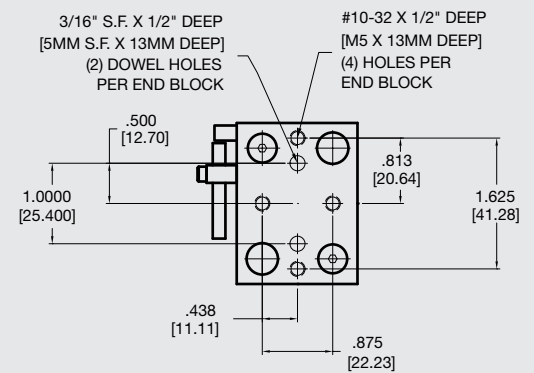
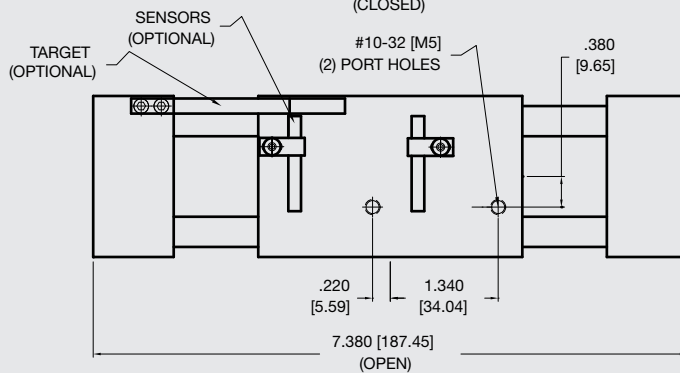
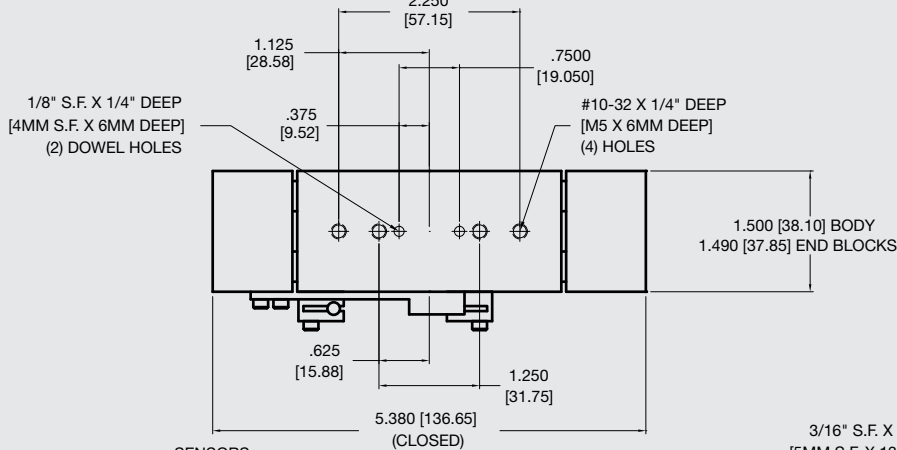
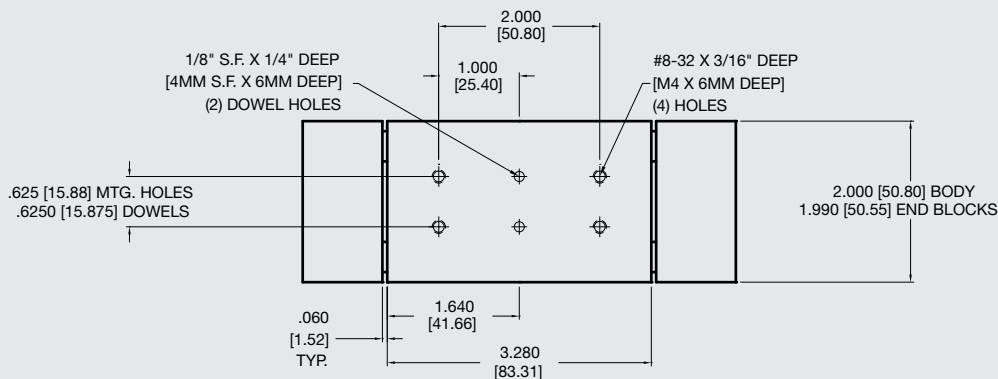

Unless noted, all tolerances are as indicated here:



All Dowel Holes are SF (Slip Fit) Locational Tolerance $\pm .0005"$ [0.13mm]



Metric Threads Course Pitch

Imperial: Inch

0.00 = $\pm .01$
0.000 = $\pm .005$
0.0000 = $\pm .0005$

Metric: [0.] = $\pm .25$
[mm] [0.0] = $\pm .13$
[0.00] = $\pm .013$



AGW-375-4 Parallel Gripper

Wide-Body, Synchronous/Non-Synchronous



FEATURES AND BENEFITS

- Ultra high gripping force to weight ratio due to four opposing independent pistons that direct power to the jaws.
- True parallel jaw motion for easy tooling.
- Units are permanently lubricated for non-lube air operation, allowing for compliance with OSHA regulations.
- Large jaw support shafts are guided through the full width of the main body.
- Proximity switches are available to monitor open and closed position of the jaws.
- The AGW Series is fully field repairable for cost savings and minimum down time.
- Non-synchronous versions allow the gripper's jaws to comply to the part's centerline versus the gripper's centerline.

SPECIFICATIONS

Design: Parallel, Double Acting, Synchronized Jaws

Stroke: 4 in [101.6 mm]

Gripping Force @ 80 PSI Per Jaw [5.5 BAR]

Closing: 36 lbs [160 N]

Opening: 38 lbs [170 N]

Time:

Close: 0.6 sec [0.6 sec]

Open: 0.6 sec [0.6 sec]

Pressure Range:

Low/High 20-120 PSI [1.7-8 BAR]

Temperature Range:

Low/High -20°/180°F [-28°/80°C]

Side Play:

± 0.001 [.03 mm]

Repeatability from Center:

± 0.002 [.06 mm]

Loading Capacity:

	Static	Dynamic
Max Tensile T	100 lbs [445 N]	20 lbs [89 N]
Max Compressive C	100 lbs [445 N]	20 lbs [89 N]

Max Moment M_x 175 in/lb [19.5 Nm] 35 in/lb [4 Nm]

Max Moment M_y 250 in/lb [28 Nm] 50 in/lb [5.6 Nm]

Max Moment M_z 175 in/lb [19.5 Nm] 35 in/lb [4 Nm]

Material: High Strength, Hard Coated aluminum bronze alloys, Steel

Weight: 3.2 lbs [1.5 kg]

Piston Diameter: .625 in x 4 [15.8 mm]

January 2009 - PATENTED Made in the USA

HOLDING FORCES CHART

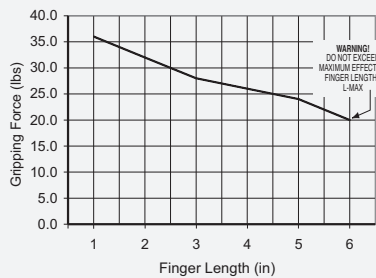

WARNING! Do not exceed tooling jaw length. See Chart above.

LOADING INFORMATION

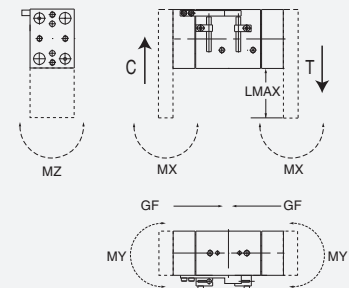

LOOK! More Technical specifications for sensors on "Sensors Accessories" page.

HOW TO ORDER

When ordering, please specify: Design/Model Number and Options.

DESIGN/MODEL

- AGW-250
- AGW-375-1
- AGW-375-2
- AGW-375-4
- AGW-500-1
- AGW-500-2
- AGW-500-4
- AGW-625-2
- AGW-625-4
- AGW-625-6

SENSOR OPTIONS

- 1 = CLOSED
- 2 = OPEN
- 3 = BOTH

SENSOR TYPE*

- 1 = NPN
- 2 = PNP



TYPE
M = METRIC
= IMPERIAL

NON-SYNCHRONIZED OPTION

SENSOR CONNECTOR
1 = POTTED
2 = QUICK DISCONNECT
3 = QUICK DISCONNECT WITH RIGHT ANGLE

* NOTE: Proximity 4mm dia., 5-24 VDC, 22 mA and comes with 2 meter cable.

Sensor Part # SNQ04, SNC04, SPC04, SPQ04

AGW-375-4 Parallel Gripper

Wide-Body, Synchronous/Non-Synchronous

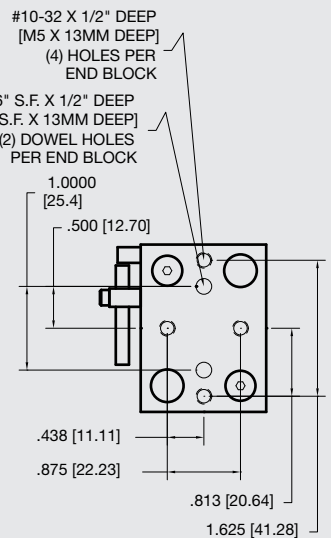
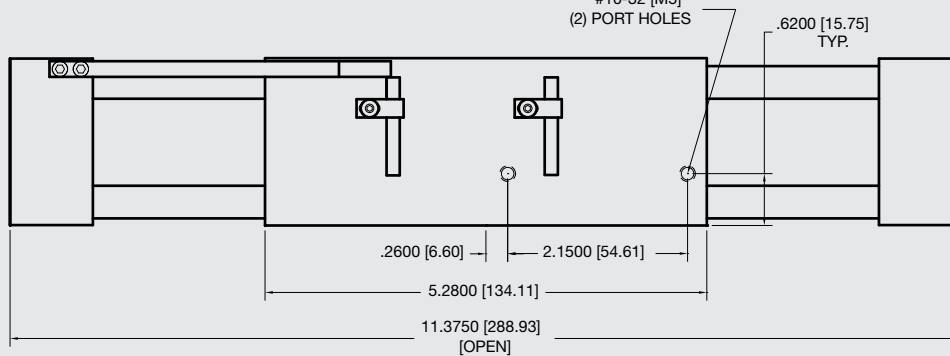
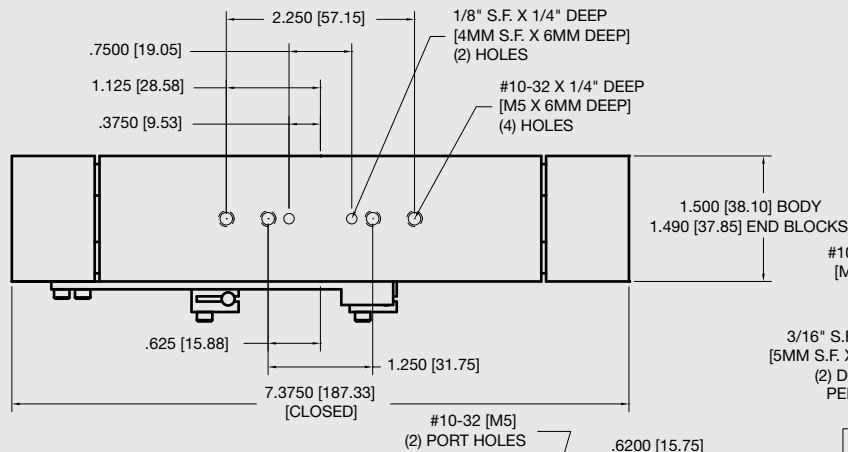
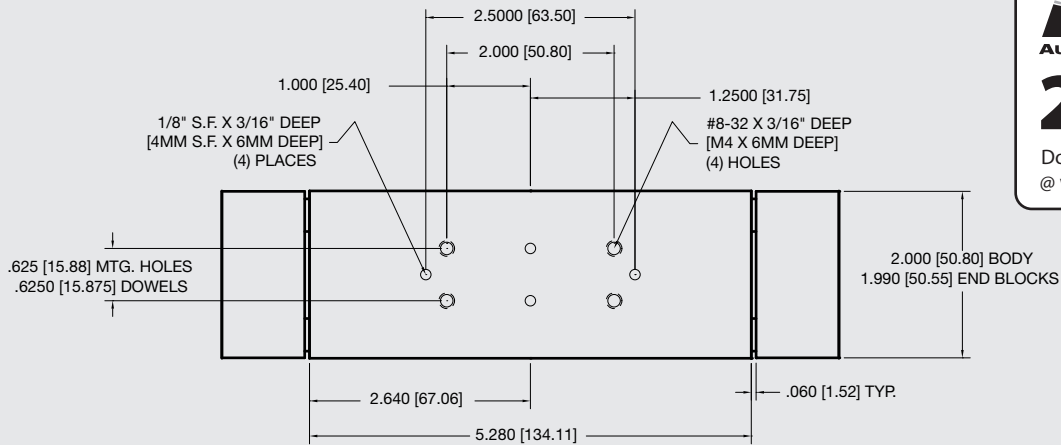

Unless noted, all tolerances are as indicated here:



All Dowel Holes are SF (Slip Fit) Locational Tolerance $\pm .0005$ " [0.13mm]



Metric Threads Course Pitch

Imperial:
Inch 0.00 = ± 0.01
0.000 = ± 0.005
0.0000 = ± 0.0005

Metric: [0.] = ± 0.25
[mm] [0.0] = ± 0.13
[0.00] = ± 0.13



AGW-500-1 Parallel Gripper

Wide-Body, Synchronous/Non-Synchronous

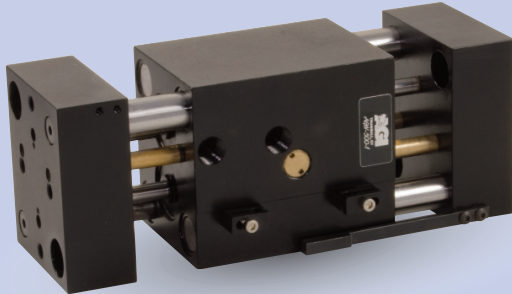

FEATURES AND BENEFITS

- Ultra high gripping force to weight ratio due to four opposing independent pistons that direct power to the jaws.
- True parallel jaw motion for easy tooling.
- Units are permanently lubricated for non-lube air operation, allowing for compliance with OSHA regulations.
- Large jaw support shafts are guided through the full width of the main body.
- Proximity switches are available to monitor open and closed position of the jaws.
- The AGW Series is fully field repairable for cost savings and minimum down time.
- Non-synchronous versions allow the gripper's jaws to comply to the part's centerline versus the gripper's centerline.

SPECIFICATIONS

Design: Parallel, Double Acting, Synchronized Jaws

Stroke: 1.5 in [38.1 mm]

Gripping Force @ 80 PSI Per Jaw [5.5 BAR]

Closing: 84 lbs [373 N]

Opening: 86 lbs [383 N]

Time:

Close: 0.3 sec [0.3 sec]

Open: 0.3 sec [0.3 sec]

Pressure Range:

Low/High 20-120 PSI [1.7-8 BAR]

Temperature Range:

Low/High -20°/180°F [-28°/80°C]

Side Play:

± 0.001 [.03 mm]

Repeatability from Center:

± 0.002 [.06 mm]

Loading Capacity:

	Static	Dynamic
Max Tensile T	500 lbs [2220 N]	50 lbs [222 N]
Max Compressive C	500 lbs [2220 N]	50 lbs [222 N]

Max Moment M_x 500 in/lb [56.5 Nm] 50 in/lb [5.6 Nm]

Max Moment M_y 750 in/lb [85 Nm] 75 in/lb [8.5 Nm]

Max Moment M_z 500 in/lb [56.5 Nm] 50 in/lb [5.6 Nm]

Material: High Strength, Hard Coated aluminum bronze alloys, Steel

Weight: 3 lbs [1.4 kg]

Piston Diameter: .875 in x 4 [22.3 mm]

January 2009 - PATENTED Made in the USA

HOLDING FORCES CHART

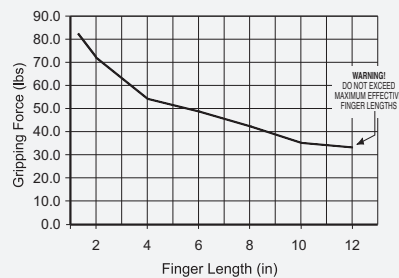

WARNING! Do not exceed tooling jaw length. See Chart above.

LOADING INFORMATION

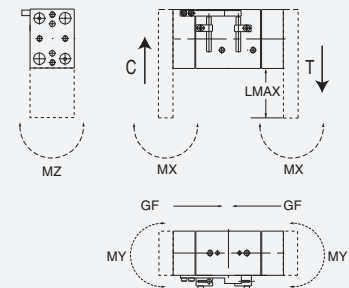

LOOK! More Technical specifications for sensors on "Sensors Accessories" page.

HOW TO ORDER

When ordering, please specify:
Design/Model Number and Options.

DESIGN/MODEL

- AGW-250
- AGW-375-1
- AGW-375-2
- AGW-375-4
- AGW-500-1
- AGW-500-2
- AGW-500-4
- AGW-625-2
- AGW-625-4
- AGW-625-6

SENSOR OPTIONS

- 1 = CLOSED
- 2 = OPEN
- 3 = BOTH

SENSOR TYPE*

- 1 = NPN
- 2 = PNP



TYPE
M = METRIC
= IMPERIAL

NON-SYNCHRONIZED OPTION

SENSOR CONNECTOR

- 1 = POTTED
- 2 = QUICK DISCONNECT
- 3 = QUICK DISCONNECT WITH RIGHT ANGLE

* NOTE: Proximity 4mm dia., 5-24 VDC, 22 mA and comes with 2 meter cable.

Sensor Part # SNQ04, SNC04, SPC04, SPQ04

AGW-500-1 Parallel Gripper

Wide-Body, Synchronous/Non-Synchronous

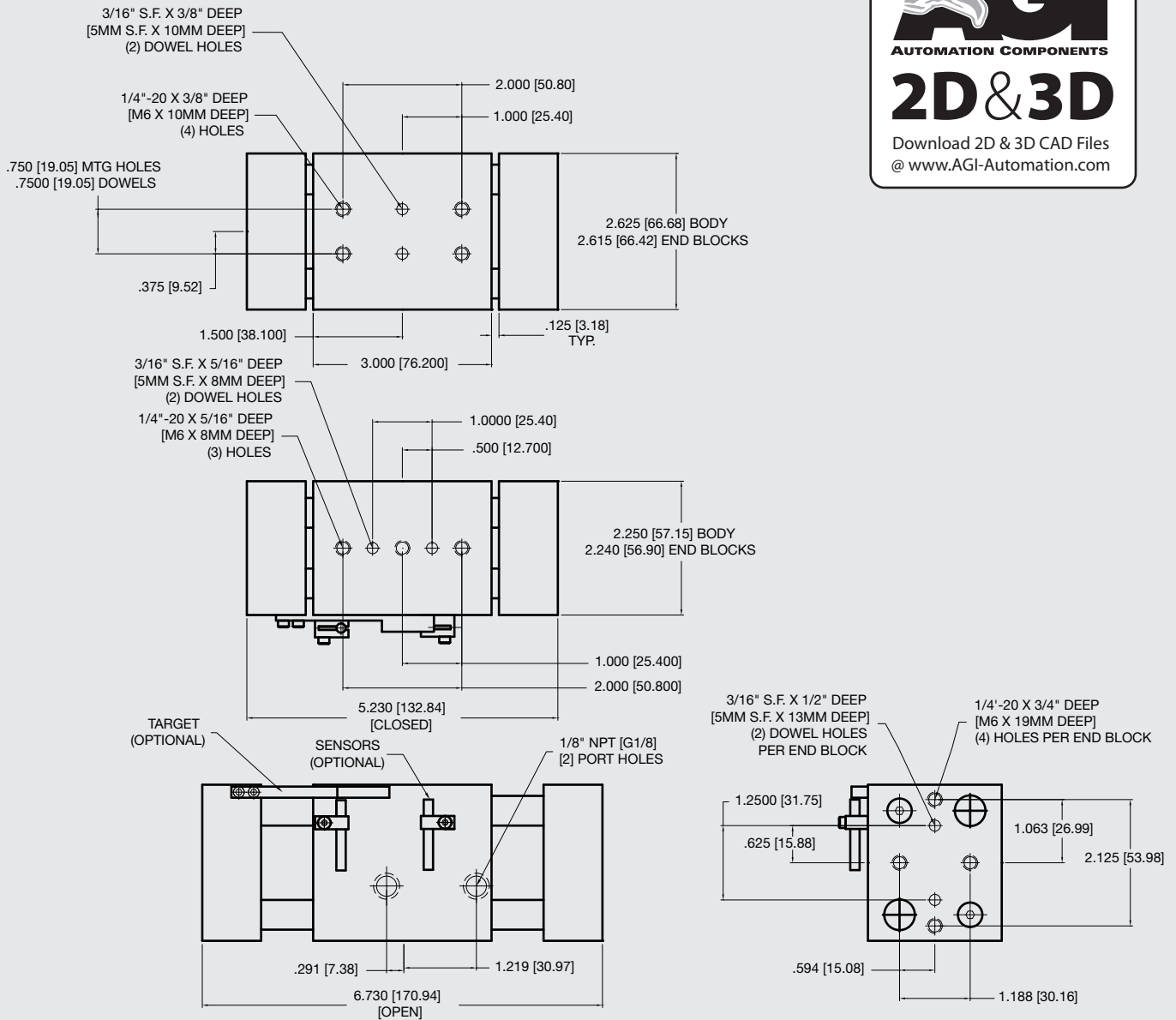

Unless noted, all tolerances are as indicated here:



All Dowel Holes are SF (Slip Fit) Locational Tolerance $\pm .0005$ " [0.013mm]



Metric Threads Course Pitch

Imperial:
 0.00 = ± 0.01
 0.000 = ± 0.005
 0.0000 = ± 0.0005

Metric: [0.] = ± 0.25
 [mm] [0.0] = ± 0.13
 [0.00] = ± 0.013



AGW-500-2 Parallel Gripper

Wide-Body, Synchronous/Non-Synchronous

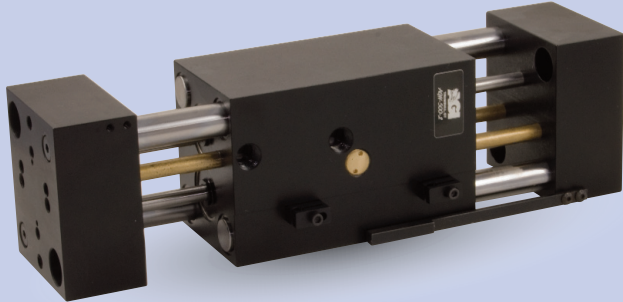

FEATURES AND BENEFITS

- Ultra high gripping force to weight ratio due to four opposing independent pistons that direct power to the jaws.
- True parallel jaw motion for easy tooling.
- Units are permanently lubricated for non-lube air operation, allowing for compliance with OSHA regulations.
- Large jaw support shafts are guided through the full width of the main body.
- Proximity switches are available to monitor open and closed position of the jaws.
- The AGW Series is fully field repairable for cost savings and minimum down time.
- Non-synchronous versions allow the gripper's jaws to comply to the part's centerline versus the gripper's centerline.

SPECIFICATIONS

Design: Parallel, Double Acting, Synchronized Jaws

Stroke: 2.5 in [63.5 mm]

Gripping Force @ 80 PSI Per Jaw [5.5 BAR]

Closing: 84 lbs [373 N]

Opening: 86 lbs [383 N]

Time:

Close: 0.3 sec [0.3 sec]

Open: 0.3 sec [0.3 sec]

Pressure Range:

Low/High 20-120 PSI [1.7-8 BAR]

Temperature Range:

Low/High -20°/180°F [-28°/80°C]

Side Play:

± 0.001 [.03 mm]

Repeatability from Center:

± 0.002 [.06 mm]

Loading Capacity:

	Static	Dynamic
Max Tensile T	500 lbs [2220 N]	50 lbs [222 N]
Max Compressive C	500 lbs [2220 N]	50 lbs [222 N]
Max Moment M_x	500 in/lb [56.5 Nm]	50 in/lb [5.6 Nm]
Max Moment M_y	750 in/lb [85 Nm]	75 in/lb [8.5 Nm]
Max Moment M_z	500 in/lb [56.5 Nm]	50 in/lb [5.6 Nm]

Material: High Strength, Hard Coated aluminum bronze alloys, Steel

Weight: 4 lbs [1.8 kg]

Piston Diameter: .875 in x 4 [22.3 mm]

January 2009 - PATENTED Made in the USA

HOLDING FORCES CHART

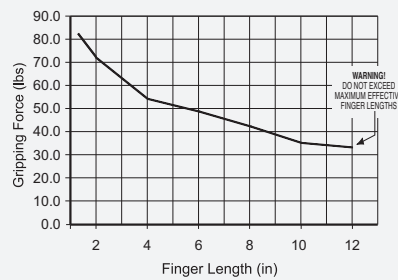

WARNING! Do not exceed tooling jaw length. See Chart above.

LOADING INFORMATION

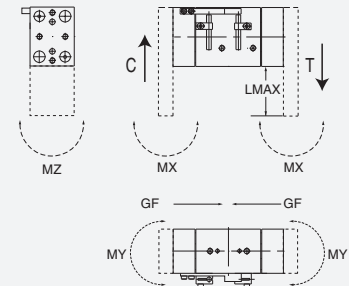

LOOK! More Technical specifications for sensors on "Sensors Accessories" page.

HOW TO ORDER

When ordering, please specify:
Design/Model Number and Options.

DESIGN/MODEL

- AGW-250
- AGW-375-1
- AGW-375-2
- AGW-375-4
- AGW-500-1
- AGW-500-2
- AGW-500-4
- AGW-625-2
- AGW-625-4
- AGW-625-6

SENSOR OPTIONS

- 1 = CLOSED
- 2 = OPEN
- 3 = BOTH

SENSOR TYPE*

- 1 = NPN
- 2 = PNP



TYPE
M = METRIC
= IMPERIAL

NON-SYNCHRONIZED OPTION

SENSOR CONNECTOR

- 1 = POTTED
- 2 = QUICK DISCONNECT
- 3 = QUICK DISCONNECT WITH RIGHT ANGLE

* NOTE: Proximity 4mm dia., 5-24 VDC, 22 mA and comes with 2 meter cable.

Sensor Part # SNQ04, SNC04, SPC04, SPQ04

AGW-500-2 Parallel Gripper

Wide-Body, Synchronous/Non-Synchronous

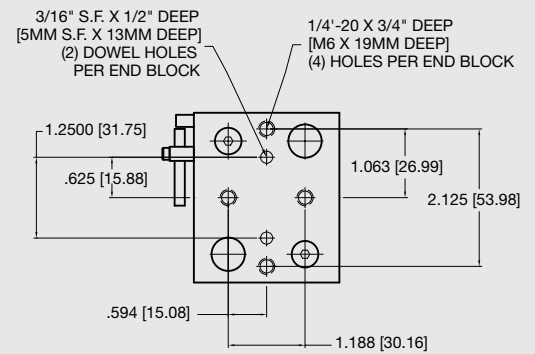
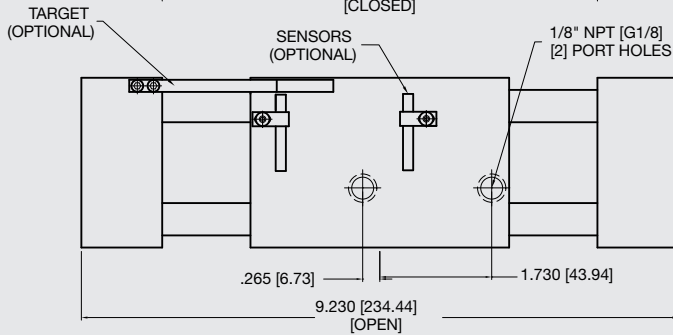
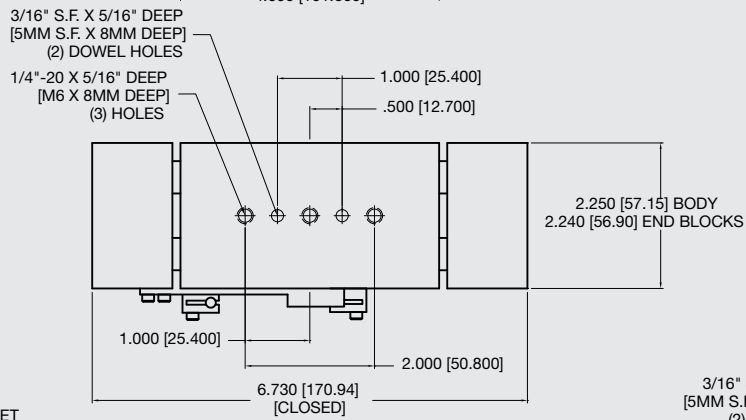
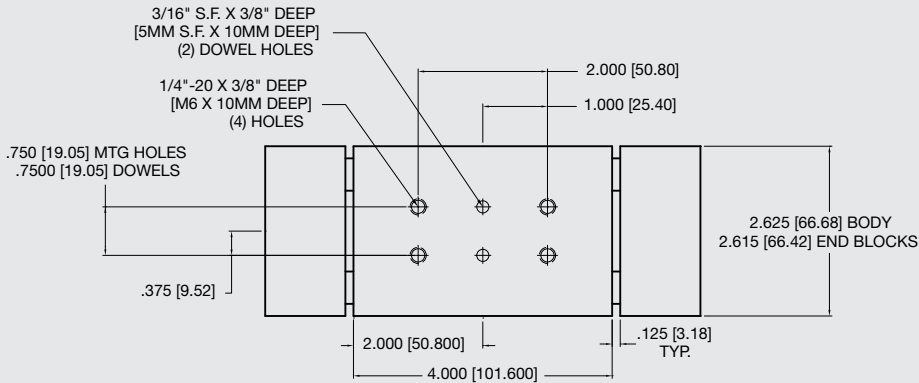

Unless noted, all tolerances are as indicated here:



All Dowel Holes are SF (Slip Fit) Locational Tolerance ± .0005" [0.13mm]



Metric Threads Course Pitch

Imperial: 0.00 = ±.01
Inch 0.000 = ±.005
0.0000 = ±.0005

Metric: [0.] = ±.25
[mm] [0.0] = ±.13
[0.00] = ±.013



AGW-500-4 Parallel Gripper

Wide-Body, Synchronous/Non-Synchronous

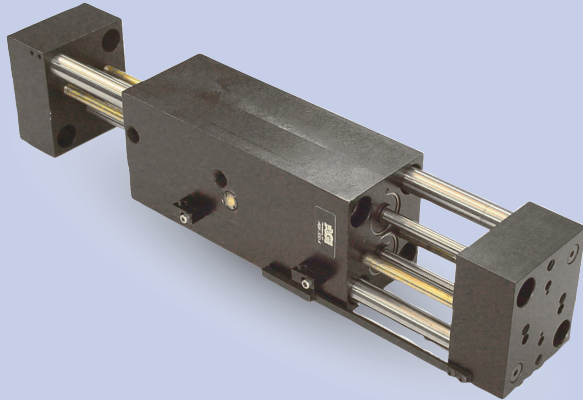

FEATURES AND BENEFITS

- Ultra high gripping force to weight ratio due to four opposing independent pistons that direct power to the jaws.
- True parallel jaw motion for easy tooling.
- Units are permanently lubricated for non-lube air operation, allowing for compliance with OSHA regulations.
- Large jaw support shafts are guided through the full width of the main body.
- Proximity switches are available to monitor open and closed position of the jaws.
- The AGW Series is fully field repairable for cost savings and minimum down time.
- Non-synchronous versions allow the gripper's jaws to comply to the part's centerline versus the gripper's centerline.

SPECIFICATIONS

Design: Parallel, Double Acting, Synchronized Jaws

Stroke: 4 in [101.6 mm]

Gripping Force @ 80 PSI Per Jaw [5.5 BAR]

Closing: 84 lbs [373 N]

Opening: 86 lbs [383 N]

Time:

Close: 0.5 sec [0.5 sec]

Open: 0.5 sec [0.5 sec]

Pressure Range:

Low/High 20-120 PSI [1.7-8 BAR]

Temperature Range:

Low/High -20°/180°F [-28°/80°C]

Side Play:

± 0.001 [.03 mm]

Repeatability from Center:

± 0.002 [.06 mm]

Loading Capacity:

	Static	Dynamic
Max Tensile T	500 lbs [2220 N]	50 lbs [222 N]
Max Compressive C	500 lbs [2220 N]	50 lbs [222 N]
Max Moment M_x	500 in/lb [56.5 Nm]	50 in/lb [5.6 Nm]
Max Moment M_y	750 in/lb [85 Nm]	75 in/lb [8.5 Nm]
Max Moment M_z	500 in/lb [56.5 Nm]	50 in/lb [5.6 Nm]

Material: High Strength, Hard Coated aluminum bronze alloys, Steel

Weight: 6 lbs [2.7 kg]

Piston Diameter: .875 in x 4 [22.3 mm]

January 2009 - PATENTED Made in the USA

HOLDING FORCES CHART

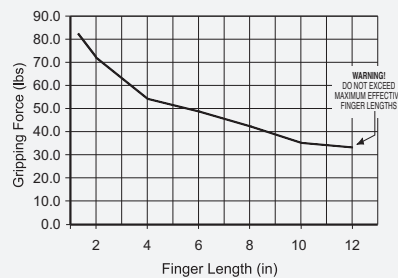

WARNING! Do not exceed tooling jaw length. See Chart above.

LOADING INFORMATION

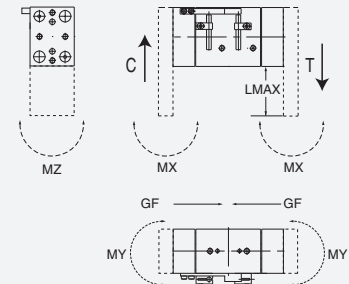

LOOK! More Technical specifications for sensors on "Sensors Accessories" page.

HOW TO ORDER

When ordering, please specify:
Design/Model Number and Options.

DESIGN/MODEL

- AGW-250
- AGW-375-1
- AGW-375-2
- AGW-375-4
- AGW-500-1
- AGW-500-2
- AGW-500-4
- AGW-625-2
- AGW-625-4
- AGW-625-6

SENSOR OPTIONS

- 1 = CLOSED
- 2 = OPEN
- 3 = BOTH

SENSOR TYPE*

- 1 = NPN
- 2 = PNP

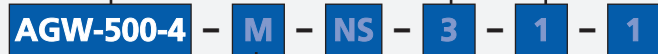

TYPE
M = METRIC
= IMPERIAL

NON-SYNCHRONIZED OPTION

SENSOR CONNECTOR

- 1 = POTTED
- 2 = QUICK DISCONNECT
- 3 = QUICK DISCONNECT WITH RIGHT ANGLE

* NOTE: Proximity 4mm dia., 5-24 VDC, 22 mA and comes with 2 meter cable.

Sensor Part # SNQ04, SNC04, SPC04, SPQ04

AGW-500-4 Parallel Gripper

Wide-Body, Synchronous/Non-Synchronous

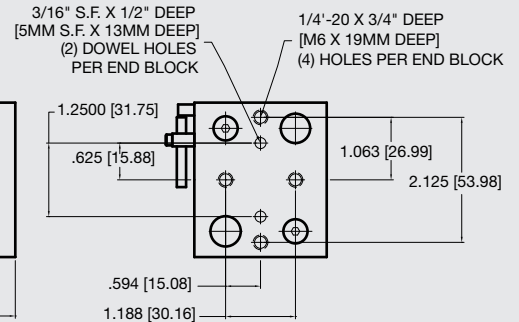
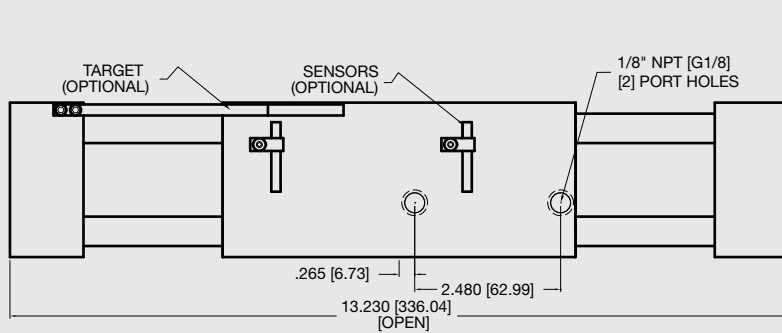
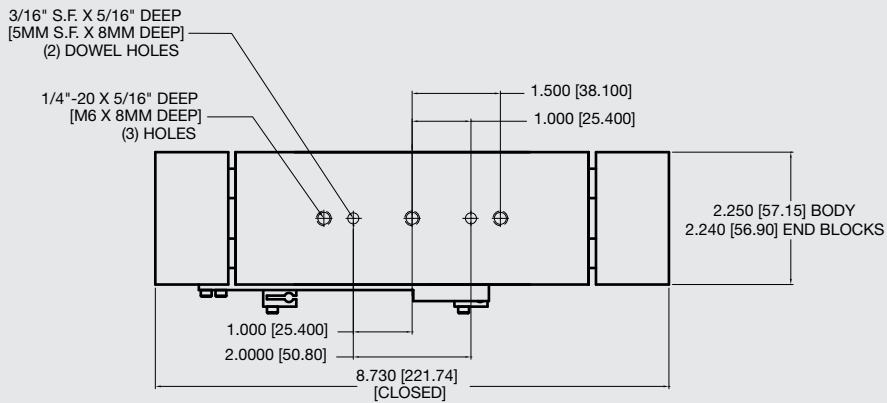
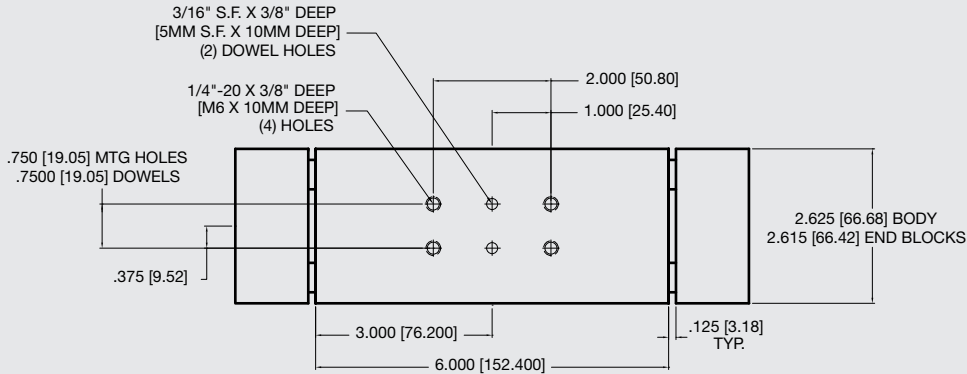

Unless noted, all tolerances are as indicated here:



All Dowel Holes are SF (Slip Fit) Locational Tolerance $\pm .0005"$ [0.013mm]



Metric Threads Course Pitch

Imperial: 0.00 = ± 0.01
Inch 0.000 = ± 0.005
0.0000 = ± 0.0005

Metric: [0.] = ± 0.25
[mm] [0.0] = ± 0.13
[0.00] = ± 0.013

AGW-625-2 Parallel Gripper

Wide-Body, Synchronous/Non-Synchronous

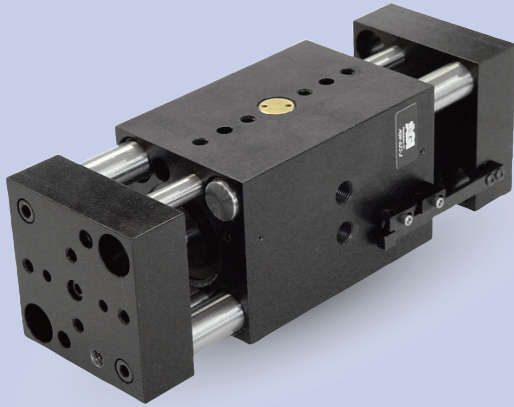

FEATURES AND BENEFITS

- Ultra high gripping force to weight ratio due to four opposing independent pistons that direct power to the jaws.
- True parallel jaw motion for easy tooling.
- Units are permanently lubricated for non-lube air operation, allowing for compliance with OSHA regulations.
- Pistons seals are quad ring type for long service life.
- Large jaw support shafts are guided through the full width of the main body.
- Proximity switches are available to monitor open and closed position of the jaws.
- The AGW Series is fully field repairable for cost savings and minimum down time.
- Non-synchronous versions allow the gripper's jaws to comply to the part's centerline versus the gripper's centerline.

SPECIFICATIONS

Design: Parallel, Double Acting, Synchronized Jaws

Stroke: 2 in [50.8 mm]

Gripping Force @ 80 PSI Per Jaw [5.5 BAR]

Closing: 130 lbs [578 N]

Opening: 132 lbs [587 N]

Time:

Close: 0.3 sec [0.3 sec]

Open: 0.3 sec [0.3 sec]

Pressure Range:

Low/High 20-120 PSI [1.7-8 BAR]

Temperature Range:

Low/High -20°/180°F [-28°/80°C]

Side Play:

± 0.001 [.03 mm]

Repeatability from Center:

± 0.002 [.06 mm]

Loading Capacity:

	Static	Dynamic
Max Tensile T	1300 lbs [5700 N]	150 lbs [667 N]
Max Compressive C	1300 lbs [5700 N]	150 lbs [667 N]

Max Moment M_x 1100 in/lb [124 Nm] 120 in/lb [13.5 Nm]

Max Moment M_y 1500 in/lb [170 Nm] 130 in/lb [14.7 Nm]

Max Moment M_z 1100 in/lb [124 Nm] 120 in/lb [13.5 Nm]

Material: High Strength, Hard Coated aluminum bronze alloys, Steel

Weight: 6.3 lbs [2.9 kg]

Piston Diameter: 1.625 in [41.3 mm]

January 2009 - PATENTED Made in the USA

HOLDING FORCES CHART

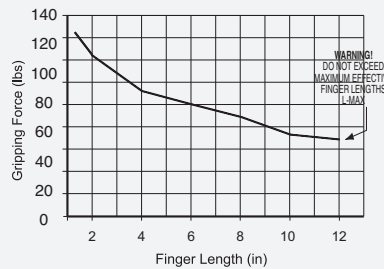

WARNING! Do not exceed tooling jaw length. See Chart above.

LOADING INFORMATION

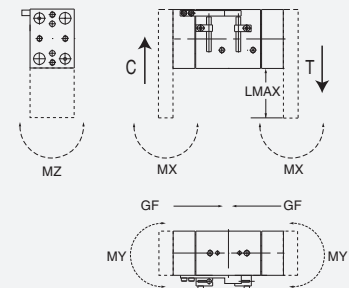

LOOK! More Technical specifications for sensors on "Sensors Accessories" page.

HOW TO ORDER

When ordering, please specify:
Design/Model Number and Options.

DESIGN/MODEL

- AGW-250
- AGW-375-1
- AGW-375-2
- AGW-375-4
- AGW-500-1
- AGW-500-2
- AGW-500-4
- AGW-625-2
- AGW-625-4
- AGW-625-6

SENSOR OPTIONS

- 1 = CLOSED
- 2 = OPEN
- 3 = BOTH

SENSOR TYPE*

- 1 = NPN
- 2 = PNP



TYPE
M = METRIC
= IMPERIAL

NON-SYNCHRONIZED OPTION

SENSOR CONNECTOR

- 1 = POTTED
- 2 = QUICK DISCONNECT
- 3 = QUICK DISCONNECT WITH RIGHT ANGLE

* NOTE: Proximity 4mm dia., 5-24 VDC, 22 mA and comes with 2 meter cable.

Sensor Part # SNQ04, SNC04, SPC04, SPQ04

AGW-625-2 Parallel Gripper

Wide-Body, Synchronous/Non-Synchronous

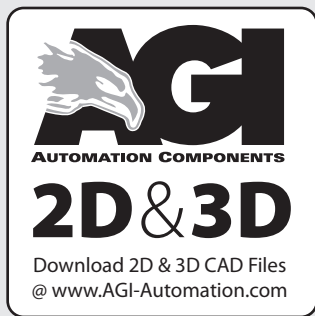
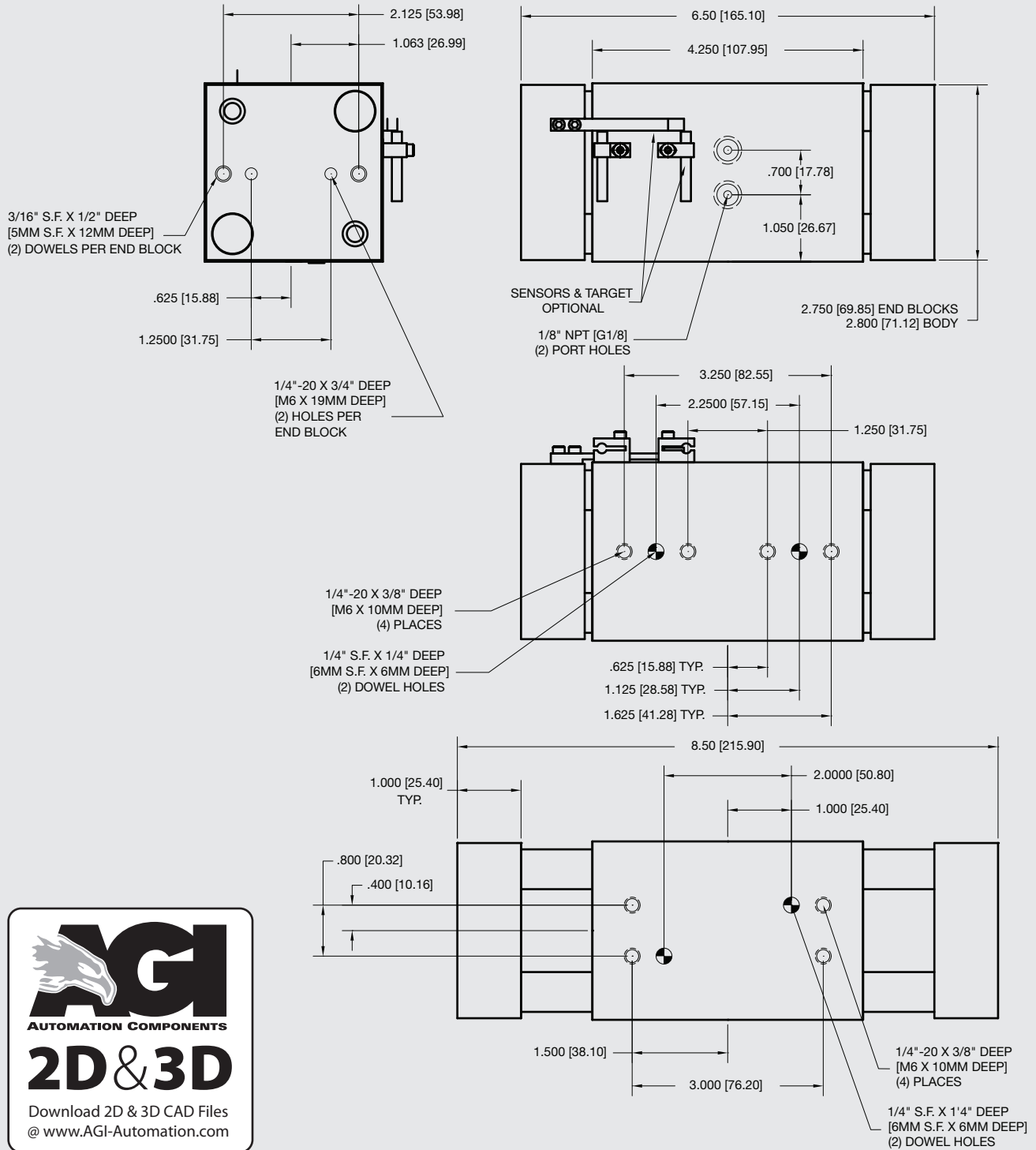

Unless noted, all tolerances are as indicated here:



All Dowel Holes are SF (Slip Fit) Locational Tolerance $\pm .0005"$ [0.13mm]



Metric Threads Course Pitch

Imperial:
Inch 0.00 = $\pm .01$
0.000 = $\pm .005$
0.0000 = $\pm .0005$

Metric: [0.] = $\pm .25$
[mm] [0.0] = $\pm .13$
[0.00] = $\pm .013$



AGW-625-4 Parallel Gripper

Wide-Body, Synchronous/Non-Synchronous

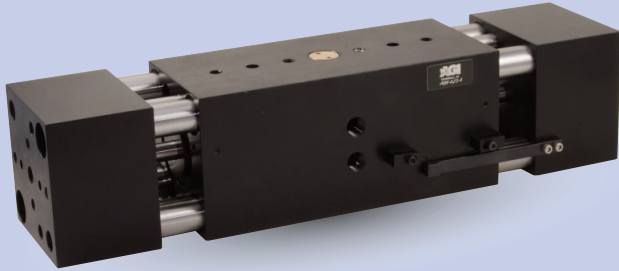

FEATURES AND BENEFITS

- Ultra high gripping force to weight ratio due to four opposing independent pistons that direct power to the jaws.
- True parallel jaw motion for easy tooling.
- Units are permanently lubricated for non-lube air operation, allowing for compliance with OSHA regulations.
- Large jaw support shafts are guided through the full width of the main body.
- Proximity switches are available to monitor open and closed position of the jaws.
- The AGW Series is fully field repairable for cost savings and minimum down time.
- Non-synchronous versions allow the gripper's jaws to comply to the part's centerline versus the gripper's centerline.

SPECIFICATIONS

Design: Parallel, Double Acting, Synchronized Jaws

Stroke: 4 in [101.6 mm]

Gripping Force @ 80 PSI Per Jaw [5.5 BAR]

Closing: 130 lbs [578 N]

Opening: 132 lbs [587 N]

Time:

Close: 0.3 sec [0.3 sec]

Open: 0.3 sec [0.3 sec]

Pressure Range:

Low/High 20-120 PSI [1.7-8 BAR]

Temperature Range:

Low/High -20°/180°F [-28°/80°C]

Side Play:

± 0.001 [.03 mm]

Repeatability from Center:

± 0.002 [.06 mm]

Loading Capacity:

	Static	Dynamic
Max Tensile T	1300 lbs [5700 N]	150 lbs [667 N]
Max Compressive C	1300 lbs [5700 N]	150 lbs [667 N]
Max Moment M_x	1100 in/lb [124 Nm]	120 in/lb [13.5 Nm]
Max Moment M_y	1500 in/lb [170 Nm]	130 in/lb [14.7 Nm]
Max Moment M_z	1100 in/lb [124 Nm]	120 in/lb [13.5 Nm]

Material: High Strength, Hard Coated aluminum bronze alloys, Steel

Weight:

8 lbs [3.6 kg]

Piston Diameter:

1.625 in [41.3 mm]

January 2009 - PATENTED Made in the USA

HOLDING FORCES CHART

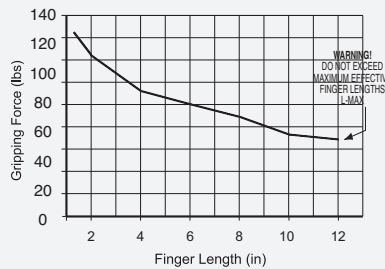

WARNING! Do not exceed tooling jaw length. See Chart above.

LOADING INFORMATION

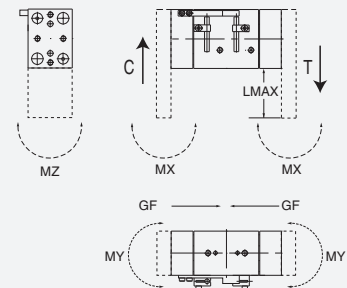

LOOK! More Technical specifications for sensors on "Sensors Accessories" page.

HOW TO ORDER

When ordering, please specify: Design/Model Number and Options.

DESIGN/MODEL

- AGW-250
- AGW-375-1
- AGW-375-2
- AGW-375-4
- AGW-500-1
- AGW-500-2
- AGW-500-4
- AGW-625-2
- AGW-625-4
- AGW-625-6

SENSOR OPTIONS

- 1 = CLOSED
- 2 = OPEN
- 3 = BOTH

SENSOR TYPE*

- 1 = NPN
- 2 = PNP



TYPE
M = METRIC
= IMPERIAL

NON-SYNCHRONIZED OPTION

SENSOR CONNECTOR
1 = POTTED
2 = QUICK DISCONNECT
3 = QUICK DISCONNECT WITH RIGHT ANGLE

* NOTE: Proximity 4mm dia., 5-24 VDC, 22 mA and comes with 2 meter cable.

Sensor Part # SNQ04, SNC04, SPC04, SPQ04

AGW-625-4 Parallel Gripper

Wide-Body, Synchronous/Non-Synchronous

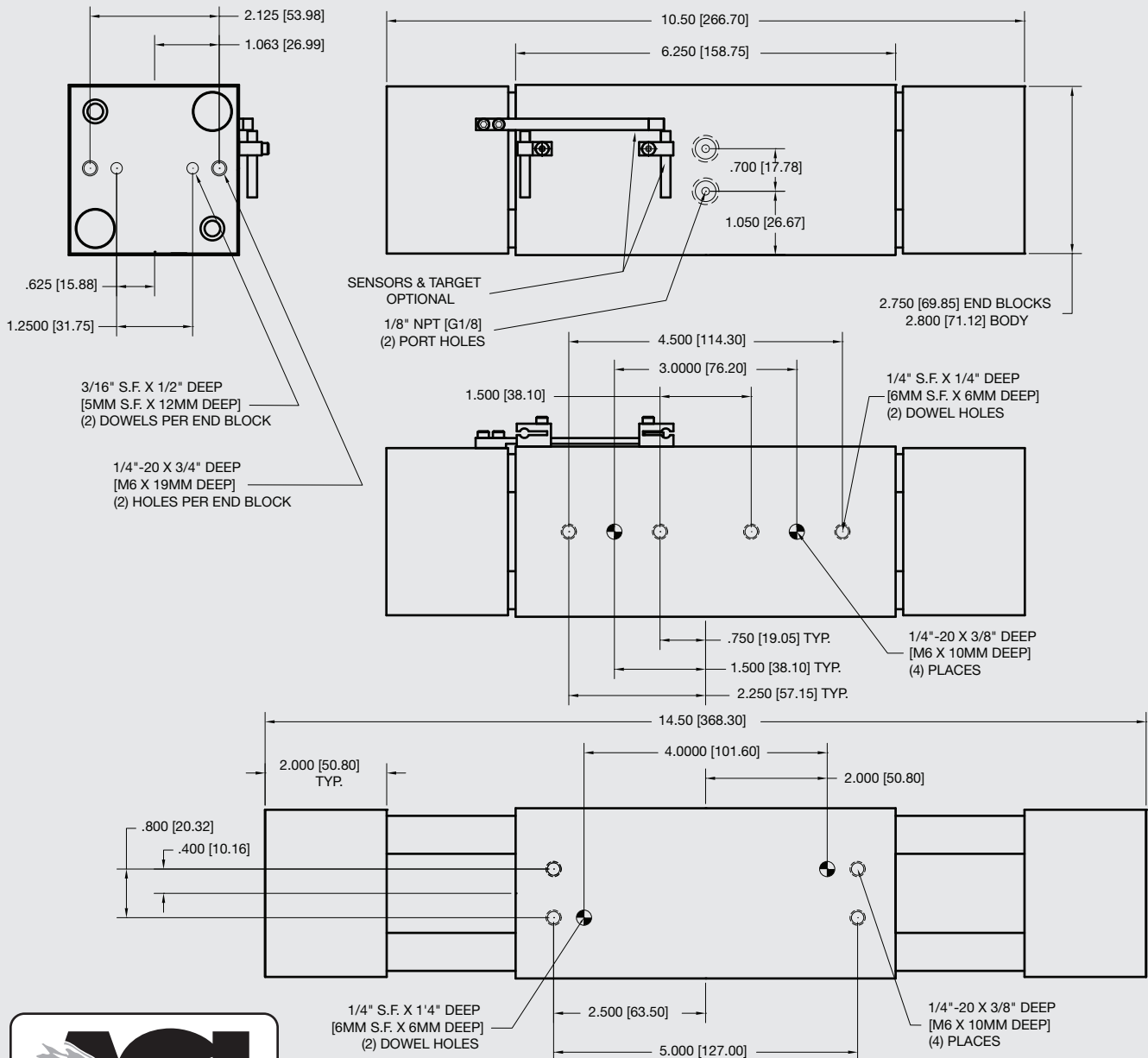

Unless noted, all tolerances are as indicated here:



All Dowel Holes are SF (Slip Fit) Locational Tolerance $\pm .0005"$ [.013mm]



Metric Threads Course Pitch

Imperial:
Inch 0.00 = $\pm .01$
0.000 = $\pm .005$
0.0000 = $\pm .0005$

Metric: [0.] = $\pm .25$
[mm] [0.0] = $\pm .13$
[0.00] = $\pm .013$



AGW-625-6 Parallel Gripper

Wide-Body, Synchronous/Non-Synchronous

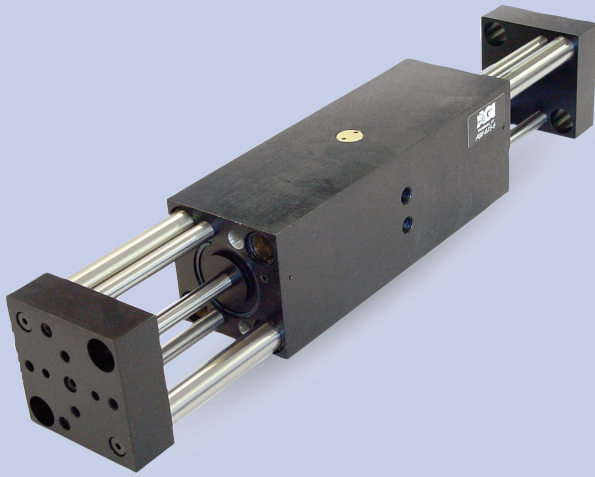

FEATURES AND BENEFITS

- Ultra high gripping force to weight ratio due to four opposing independent pistons that direct power to the jaws.
- True parallel jaw motion for easy tooling.
- Units are permanently lubricated for non-lube air operation, allowing for compliance with OSHA regulations.
- Large jaw support shafts are guided through the full width of the main body.
- Proximity switches are available to monitor open and closed position of the jaws.
- The AGW Series is fully field repairable for cost savings and minimum down time.
- Non-synchronous versions allow the gripper's jaws to comply to the part's centerline versus the gripper's centerline.

SPECIFICATIONS

Design: Parallel, Double Acting, Synchronized Jaws

Stroke: 6 in [152.4 mm]

Gripping Force @ 80 PSI Per Jaw [5.5 BAR]

Closing: 130 lbs [578 N]

Opening: 132 lbs [587 N]

Time:

Close: 0.3 sec [0.3 sec]

Open: 0.3 sec [0.3 sec]

Pressure Range:

Low/High 20-120 PSI [1.7-8 BAR]

Temperature Range:

Low/High -20°/180°F [-28°/80°C]

Side Play:

± 0.001 [.03 mm]

Repeatability from Center:

± 0.002 [.06 mm]

Loading Capacity:

	Static	Dynamic
Max Tensile T	1300 lbs [5700 N]	150 lbs [667 N]
Max Compressive C	1300 lbs [5700 N]	150 lbs [667 N]

Max Moment M_x 1100 in/lb [124 Nm] 120 in/lb [13.5 Nm]

Max Moment M_y 1500 in/lb [170 Nm] 130 in/lb [14.7 Nm]

Max Moment M_z 1100 in/lb [124 Nm] 120 in/lb [13.5 Nm]

Material: High Strength, Hard Coated aluminum bronze alloys, Steel

Weight: 9.7 lbs [4.4 kg]

Piston Diameter: 1.625 in [41.3 mm]

January 2009 - PATENTED Made in the USA

HOLDING FORCES CHART

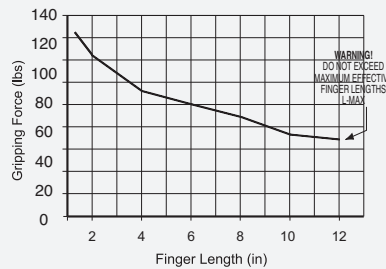

WARNING! Do not exceed tooling jaw length. See Chart above.

LOADING INFORMATION

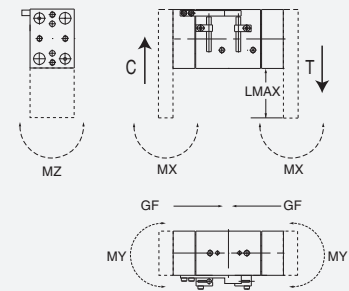

LOOK! More Technical specifications for sensors on "Sensors Accessories" page.

HOW TO ORDER

When ordering, please specify:
Design/Model Number and Options.

DESIGN/MODEL

- AGW-250
- AGW-375-1
- AGW-375-2
- AGW-375-4
- AGW-500-1
- AGW-500-2
- AGW-500-4
- AGW-625-2
- AGW-625-4
- AGW-625-6

SENSOR OPTIONS

- 1 = CLOSED
- 2 = OPEN
- 3 = BOTH

SENSOR TYPE*

- 1 = NPN
- 2 = PNP



TYPE
M = METRIC
= IMPERIAL

NON-SYNCHRONIZED OPTION

SENSOR CONNECTOR

- 1 = POTTED
- 2 = QUICK DISCONNECT
- 3 = QUICK DISCONNECT WITH RIGHT ANGLE

* NOTE: Proximity 4mm dia., 5-24 VDC, 22 mA and comes with 2 meter cable.

Sensor Part # SNQ04, SNC04, SPC04, SPQ04

AGW-625-6 Parallel Gripper

Wide-Body, Synchronous/Non-Synchronous

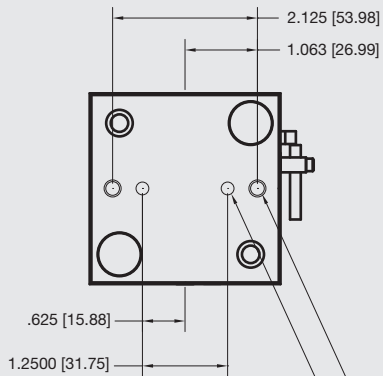

3/16" S.F. X 1/2" DEEP
[5MM S.F. X 12MM DEEP]
(2) DOWELS PER END BLOCK

1/4"-20 X 3/4" DEEP
[M6 X 19MM DEEP]
(2) HOLES PER END BLOCK

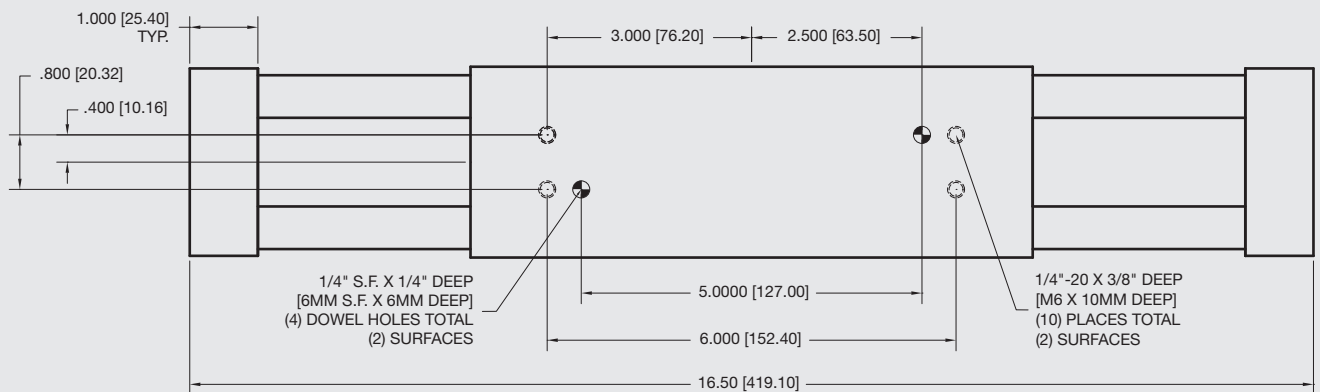
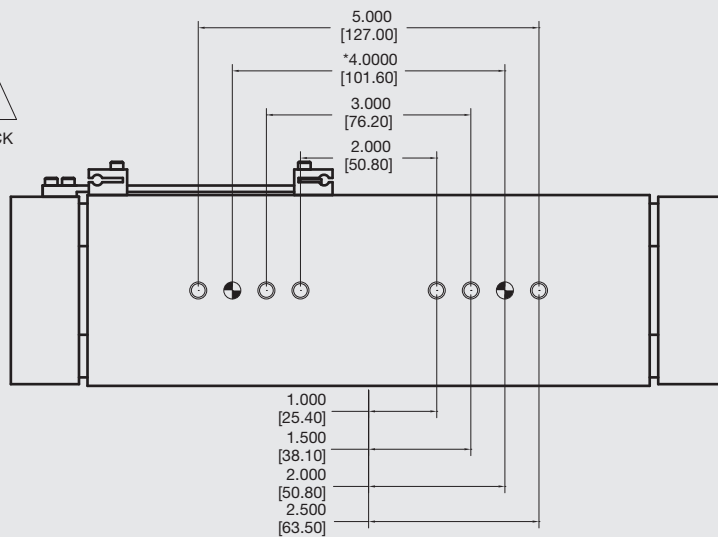
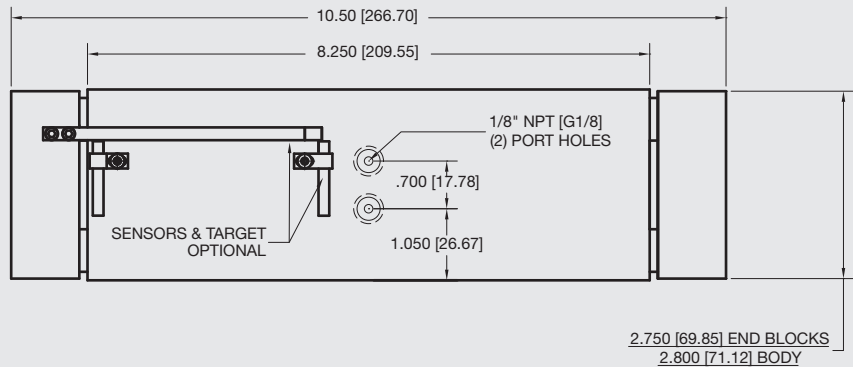

Unless noted, all tolerances are as indicated here:



All Dowel Holes are SF (Slip Fit) Locational Tolerance $\pm .0005"$ [.013mm]



Metric Threads Course Pitch

Imperial: Inch

0.00 = $\pm .01$
0.000 = $\pm .005$
0.0000 = $\pm .0005$

Metric: [0.] = $\pm .25$
[0.0] = $\pm .13$
[0.00] = $\pm .013$



AGP-23 Three Jaw Parallel Gripper

T-Slot Bearing Series



FEATURES AND BENEFITS

- Jaws are T-Slot bearing supported to prevent jaw breakage and offer superior load bearing performance.
- High gripping force to weight ratio.
- Compact design with long stroke.
- True parallel jaw motion for easy tooling.
- Units are permanently lubricated for non-lube air operation, allowing for compliance with OSHA regulations.
- Hall effect sensors are available to monitor open and closed position of the jaws.
- AGP is fully field repairable for cost savings and minimum down time.
- Multiple mounting surfaces on jaw for easy tooling.
- Optional stripper plate ensures part preload in location upon release.

SPECIFICATIONS

Design: Parallel, Double Acting, Synchronized Jaws

Stroke: .30 in [7.6mm]

Gripping Force @ 80 PSI [5.5 BAR]

Closing: 29 lbs [129 N]

Opening: 26 lbs [115 N]

Time:

Close: 0.22 sec [0.22 sec]

Open: 0.22 sec [0.22 sec]

Pressure Range:

Low/High 30-120 PSI [2-8 BAR]

Temperature Range:

Low/High -20°/180°F [-28°/80°C]

Side Play: ± 0.001 [.03 mm]

Repeatability from Center: ± 0.002 [.06 mm]

Loading Capacity:

	Static	Dynamic
Max Tensile T	300 lbs [1300 N]	100 lbs [444 N]
Max Compressive C	300 lbs [1300 N]	100 lbs [444 N]

Max Moment M_x 250 in/lb [2.8 Nm] 75 in/lb [8.5 Nm]

Max Moment M_y 250 in/lb [2.8 Nm] 75 in/lb [8.5 Nm]

Max Moment M_z 150 in/lb [17 Nm] 75 in/lb [8.5 Nm]

Material: High Strength, Hard Coated aluminum bronze alloys, Steel

Weight: 9 oz [255 g]

Piston Diameter: 1.25 in [32 mm]

January 2009 - PATENTED Made in the USA

HOLDING FORCES CHART

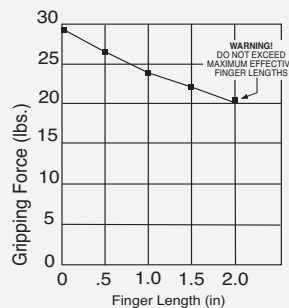

WARNING! Do not exceed tooling jaw length. See Chart above.

LOADING INFORMATION

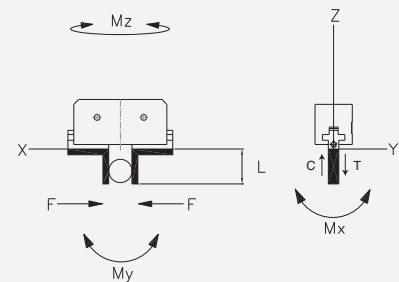

LOOK! More Technical specifications for sensors on "Sensors Accessories" page.

HOW TO ORDER

When ordering, please specify: Design/Model Number and Options.

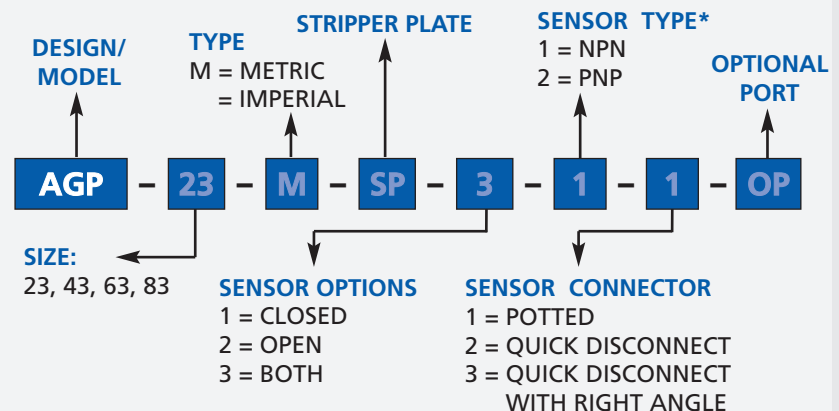

* NOTE: Hall Effect 4mm dia., 5-24 VDC, 22 mA and comes with 2 meter cable.

Sensor Part # SHN02, SHNQ4, SHP02, SHPQ4

AGP-23 Three Jaw Parallel Gripper

T-Slot Bearing Series

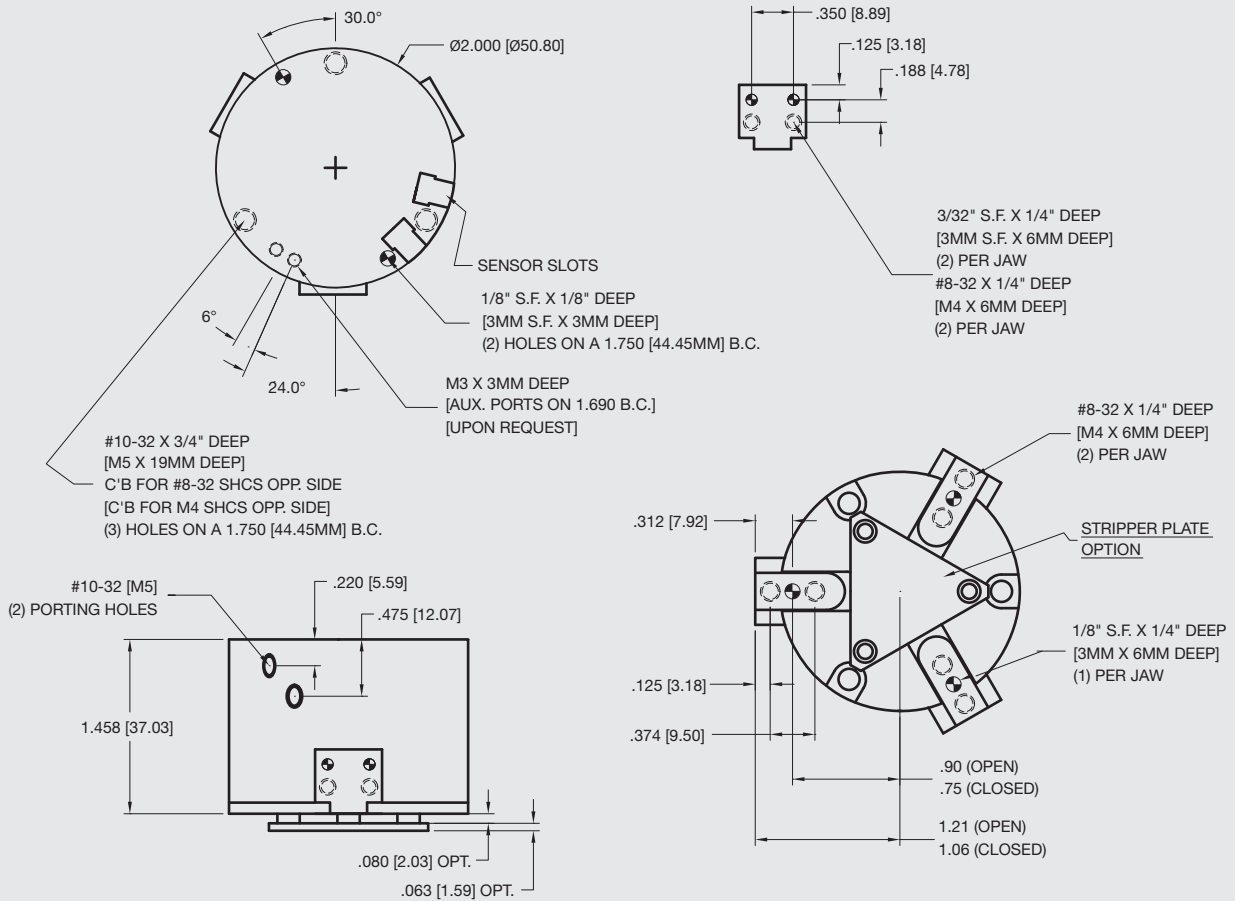

Unless noted, all tolerances are as indicated here:



All Dowel Holes are SF (Slip Fit) Locational Tolerance ± .0005" [.013mm]



Metric Threads Course Pitch

Imperial:
Inch 0.00 = ±.01
0.000 = ±.005
0.0000 = ±.0005

Metric: [0.] = ±.25
[mm] [0.0] = ±.13
[0.00] = ±.013



AGP-43 Three Jaw Parallel Gripper

T-Slot Bearing Series



FEATURES AND BENEFITS

- Jaws are T-Slot bearing supported to prevent jaw breakage and offer superior load bearing performance.
- High gripping force to weight ratio.
- Compact design with long stroke.
- True parallel jaw motion for easy tooling.
- Units are permanently lubricated for non-lube air operation, allowing for compliance with OSHA regulations.
- Hall effect sensors are available to monitor open and closed position of the jaws.
- AGP is fully field repairable for cost savings and minimum down time.
- Multiple mounting surfaces on jaw for easy tooling.
- Optional stripper plate ensures part preload in location upon release.

SPECIFICATIONS

Design: Parallel, Double Acting, Synchronized Jaws

Stroke: .40 in [10.2 mm]

Gripping Force @ 80 PSI [5.5 BAR]

Closing: 80 lbs [355 N]

Opening: 86 lbs [382 N]

Time:

Close: 0.22 sec [0.22 sec]

Open: 0.22 sec [0.22 sec]

Pressure Range:

Low/High 30-120 PSI [2-8 BAR]

Temperature Range:

Low/High -20°/180°F [-28°/80°C]

Side Play:

± 0.001 [.03 mm]

Repeatability

from Center: ± 0.002 [.06 mm]

Loading Capacity:

	Static	Dynamic
Max Tensile T	760 lbs [3380 N]	270 lbs [1200 N]
Max Compressive C	760 lbs [3380 N]	270 lbs [1200 N]

HOLDING FORCES CHART

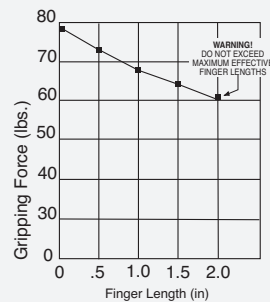

WARNING! Do not exceed tooling jaw length. See Chart above.

LOADING INFORMATION

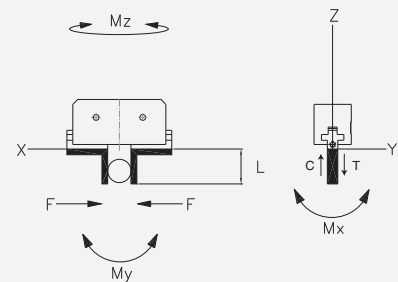

LOOK! More Technical specifications for sensors on "Sensors Accessories" page.

HOW TO ORDER

When ordering, please specify:
Design/Model Number and Options.

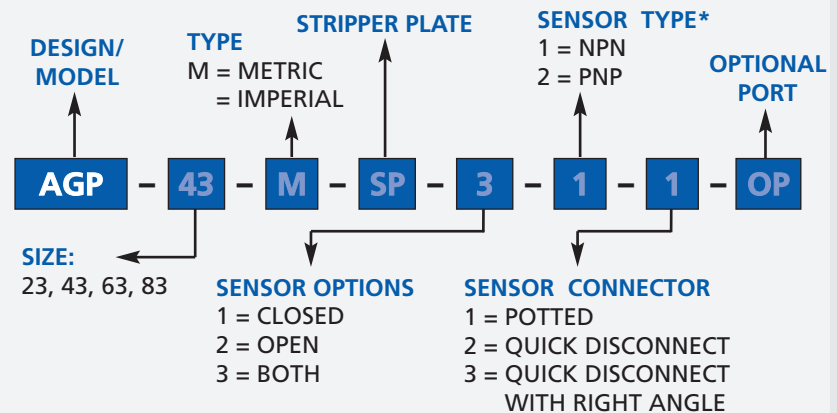

* NOTE: Hall Effect 4mm dia., 5-24 VDC, 22 mA and comes with 2 meter cable.

Sensor Part # SHN02, SHN04, SHP02, SHP04

AGP-43 Three Jaw Parallel Gripper

T-Slot Bearing Series

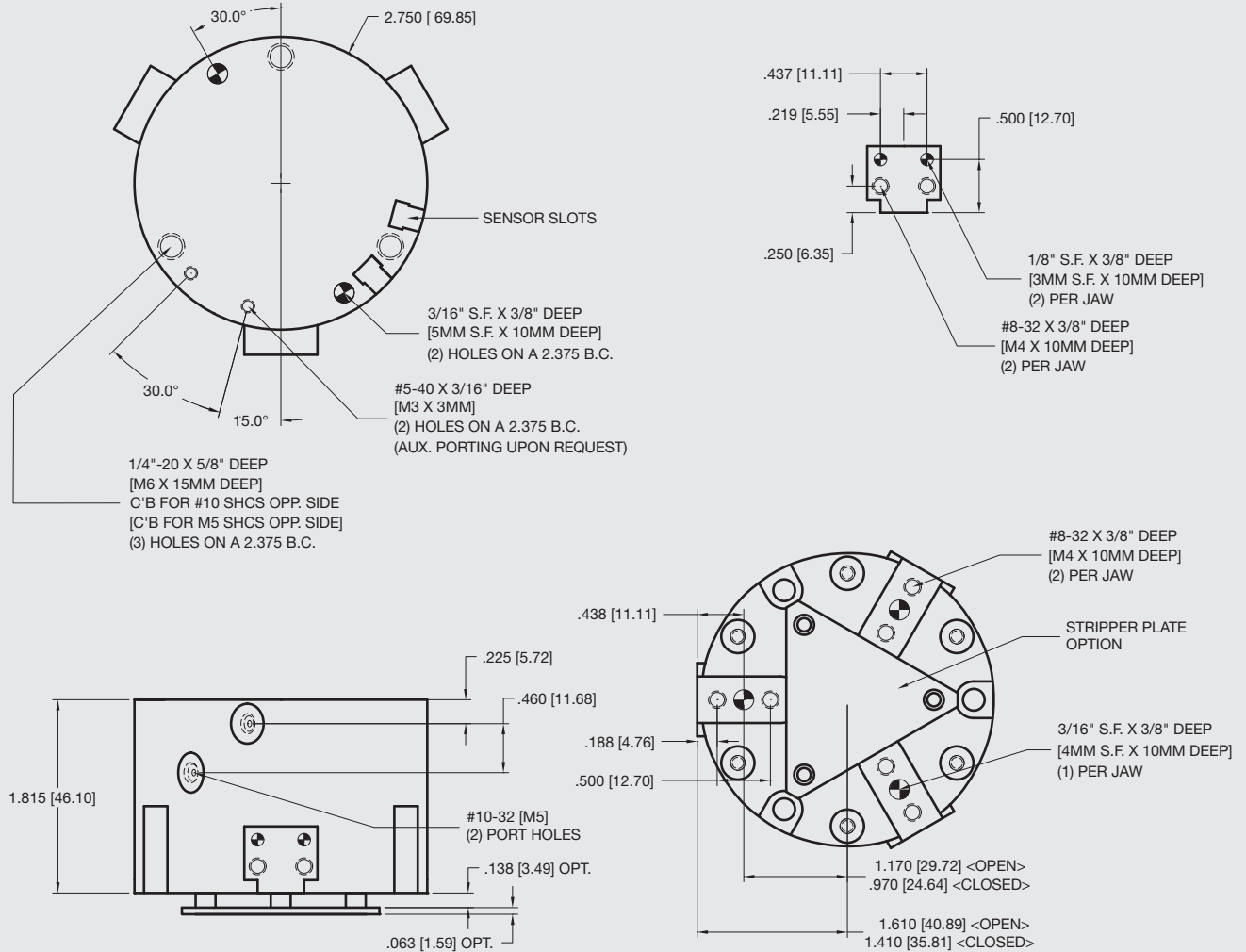

Unless noted, all tolerances are as indicated here:



All Dowel Holes are SF (Slip Fit) Locational Tolerance $\pm .0005"$ [.013mm]



Metric Threads Course Pitch

Imperial:
Inch 0.00 = $\pm .01$
0.000 = $\pm .005$
0.0000 = $\pm .0005$

Metric: [0.] = $\pm .25$
[mm] [0.0] = $\pm .13$
[0.00] = $\pm .013$

AGP-63 Three Jaw Parallel Gripper

T-Slot Bearing Series



FEATURES AND BENEFITS

- Jaws are T-Slot bearing supported to prevent jaw breakage and offer superior load bearing performance.
- High gripping force to weight ratio.
- Compact design with long stroke.
- True parallel jaw motion for easy tooling.
- Units are permanently lubricated for non-lube air operation, allowing for compliance with OSHA regulations.
- Hall effect sensors are available to monitor open and closed position of the jaws.
- AGP is fully field repairable for cost savings and minimum down time.
- Multiple mounting surfaces on jaw for easy tooling.
- Optional stripper plate ensures part preload in location upon release.

SPECIFICATIONS

Design: Parallel, Double Acting, Synchronized Jaws

Stroke: .62 in [15.7 mm]

Gripping Force @ 80 PSI [5.5 BAR]

Closing: 200 lbs [889 N]
Opening: 194 lbs [862 N]

Time:

Close: 0.22 sec [0.22 sec]
Open: 0.22 sec [0.22 sec]

Pressure Range:

Low/High 30-120 PSI [2-8 BAR]

Temperature Range:

Low/High -20°/180°F [-28°/80°C]

Side Play: ± 0.001 [.03 mm]

Repeatability from Center: ± 0.002 [.06 mm]

Loading Capacity:

	Static	Dynamic
Max Tensile T	1250 lbs [5560 N]	400 lbs [1780 N]
Max Compressive C	1250 lbs [5560 N]	400 lbs [1780 N]

Max Moment M_x 1000 in/lb [112 Nm] 400 in/lb [45 Nm]

Max Moment M_y 1000 in/lb [112 Nm] 400 in/lb [45 Nm]

Max Moment M_z 1000 in/lb [112 Nm] 300 in/lb [33.9 Nm]

Material: High Strength, Hard Coated aluminum bronze alloys, Steel

Weight: 2.3 lbs [1 kg]

Piston Diameter: 2.75 in [69.8 mm]

January 2009 - PATENTED Made in the USA

HOLDING FORCES CHART

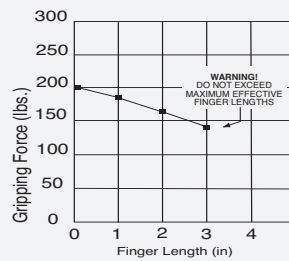

WARNING! Do not exceed tooling jaw length. See Chart above.

LOADING INFORMATION

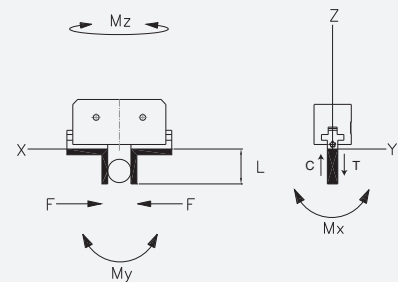

LOOK! More Technical specifications for sensors on "Sensors Accessories" page.

HOW TO ORDER

When ordering, please specify: Design/Model Number and Options.

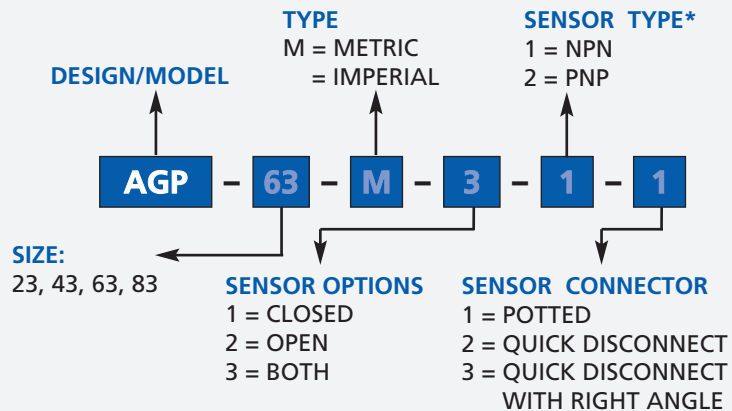

* NOTE: Hall Effect 4mm dia., 5-24 VDC, 22 mA and comes with 2 meter cable.

Sensor Part # SHN02, SHNQ4, SHP02, SHPQ4

AGP-63 Three Jaw Parallel Gripper

T-Slot Bearing Series

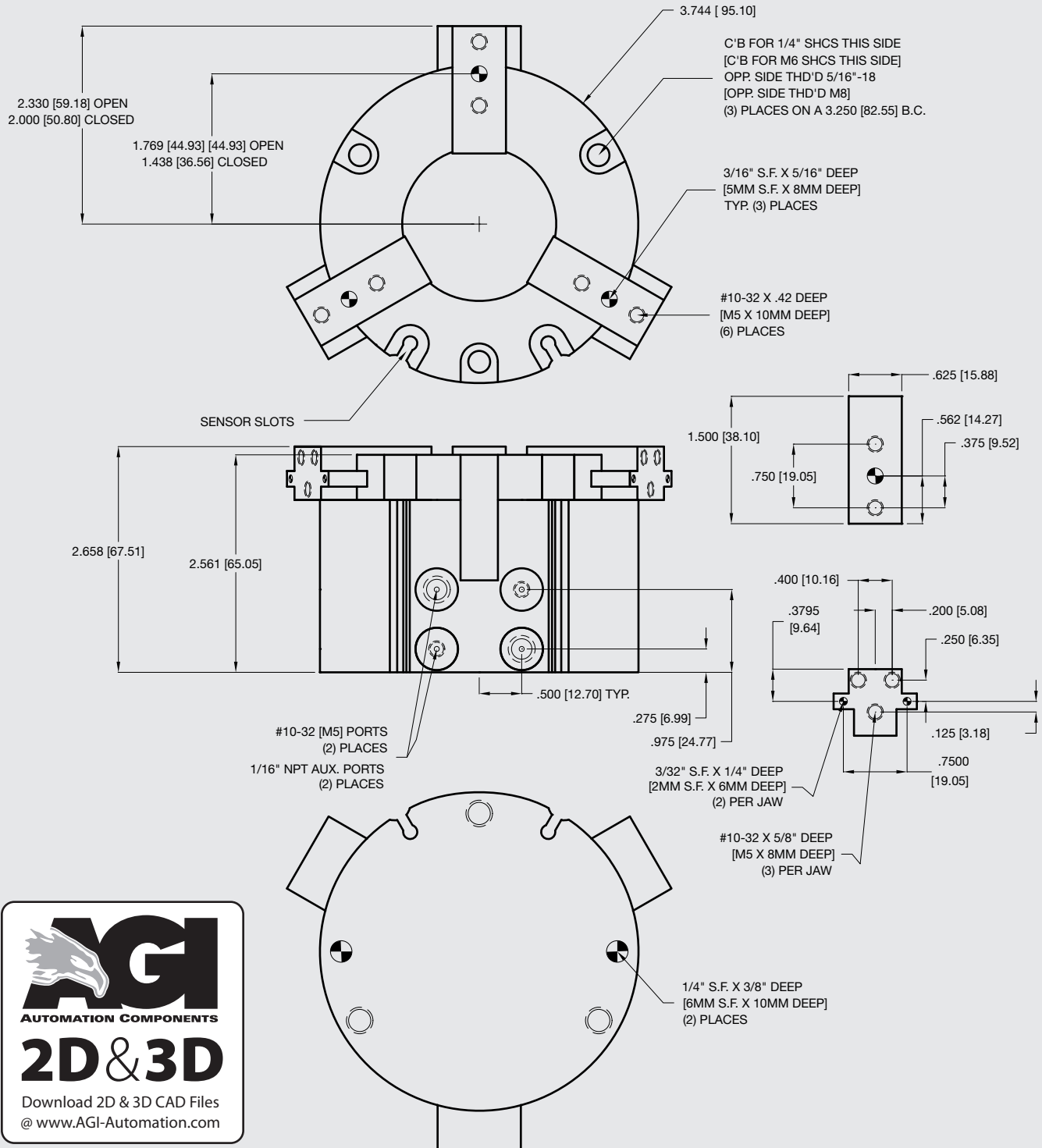

Unless noted, all tolerances are as indicated here:



All Dowel Holes are SF (Slip Fit) Locational Tolerance $\pm .0005"$ [.013mm]



Metric Threads Course Pitch

Imperial:
Inch 0.00 = $\pm .01$
0.000 = $\pm .005$
0.0000 = $\pm .0005$

Metric: [0.] = $\pm .25$
[mm] [0.0] = $\pm .13$
[0.00] = $\pm .013$



AGP-83 Three Jaw Parallel Gripper

T-Slot Bearing Series



FEATURES AND BENEFITS

- Jaws are T-Slot bearing supported to prevent jaw breakage and offer superior load bearing performance.
- High gripping force to weight ratio.
- Compact design with long stroke.
- True parallel jaw motion for easy tooling.
- Units are permanently lubricated for non-lube air operation, allowing for compliance with OSHA regulations.
- Hall effect sensors are available to monitor open and closed position of the jaws.
- AGP is fully field repairable for cost savings and minimum down time.
- Multiple mounting surfaces on jaw for easy tooling.
- Optional stripper plate ensures part preload in location upon release.

SPECIFICATIONS

Design: Parallel, Double Acting, Synchronized Jaws

Stroke: .88 in [22.3 mm]

Gripping Force @ 80 PSI [5.5 BAR]

Closing: 280 lbs [1245 N]
Opening: 285 lbs [1267 N]

Time:

Close: 0.22 sec [0.22 sec]
Open: 0.22 sec [0.22 sec]

Pressure Range:

Low/High 30-120 PSI [2-8 BAR]

Temperature Range:

Low/High -20°/180°F [-28°/80°C]

Side Play:

± 0.001 [.03 mm]

Repeatability from Center:

± 0.002 [.06 mm]

Loading Capacity:

	Static	Dynamic
Max Tensile T	2100 lbs [9300 N]	760 lbs [3380 N]
Max Compressive C	2100 lbs [9300 N]	760 lbs [3380 N]
Max Moment M_x	2100 in/lb [237 Nm]	760 in/lb [85.8 Nm]
Max Moment M_y	2100 in/lb [237 Nm]	760 in/lb [85.8 Nm]
Max Moment M_z	1600 in/lb [180 Nm]	550 in/lb [62.1 Nm]

Material: High Strength, Hard Coated aluminum bronze alloys, Steel

Weight: 6.0 lbs [2.7 kg]

Piston Diameter: 3.5 in [89 mm]

January 2009 - PATENTED Made in the USA

HOLDING FORCES CHART

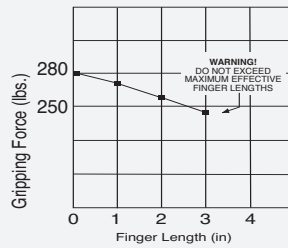

WARNING! Do not exceed tooling jaw length. See Chart above.

LOADING INFORMATION

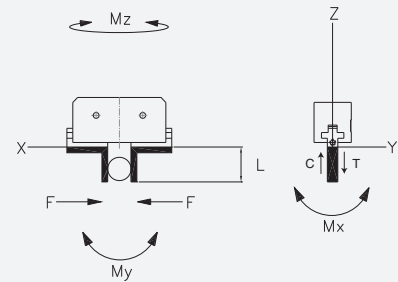

LOOK! More Technical specifications for sensors on "Sensors Accessories" page.

HOW TO ORDER

When ordering, please specify: Design/Model Number and Options.

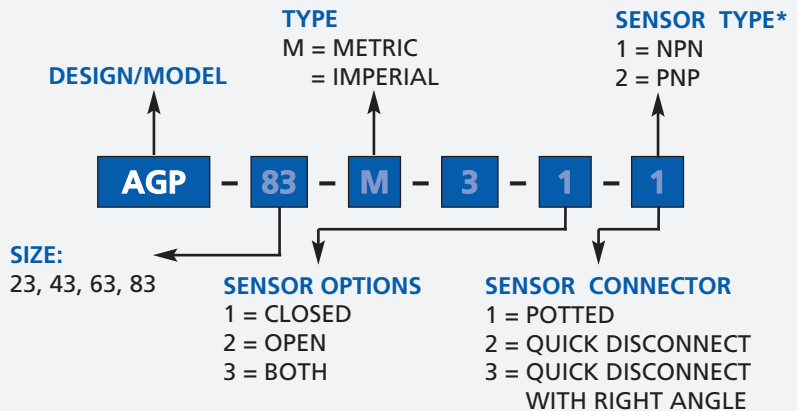

* NOTE: Hall Effect 4mm dia., 5-24 VDC, 22 mA and comes with 2 meter cable.

Sensor Part # SHN02, SHNQ4, SHP02, SHPQ4

AGP-83 Three Jaw Parallel Gripper

T-Slot Bearing Series

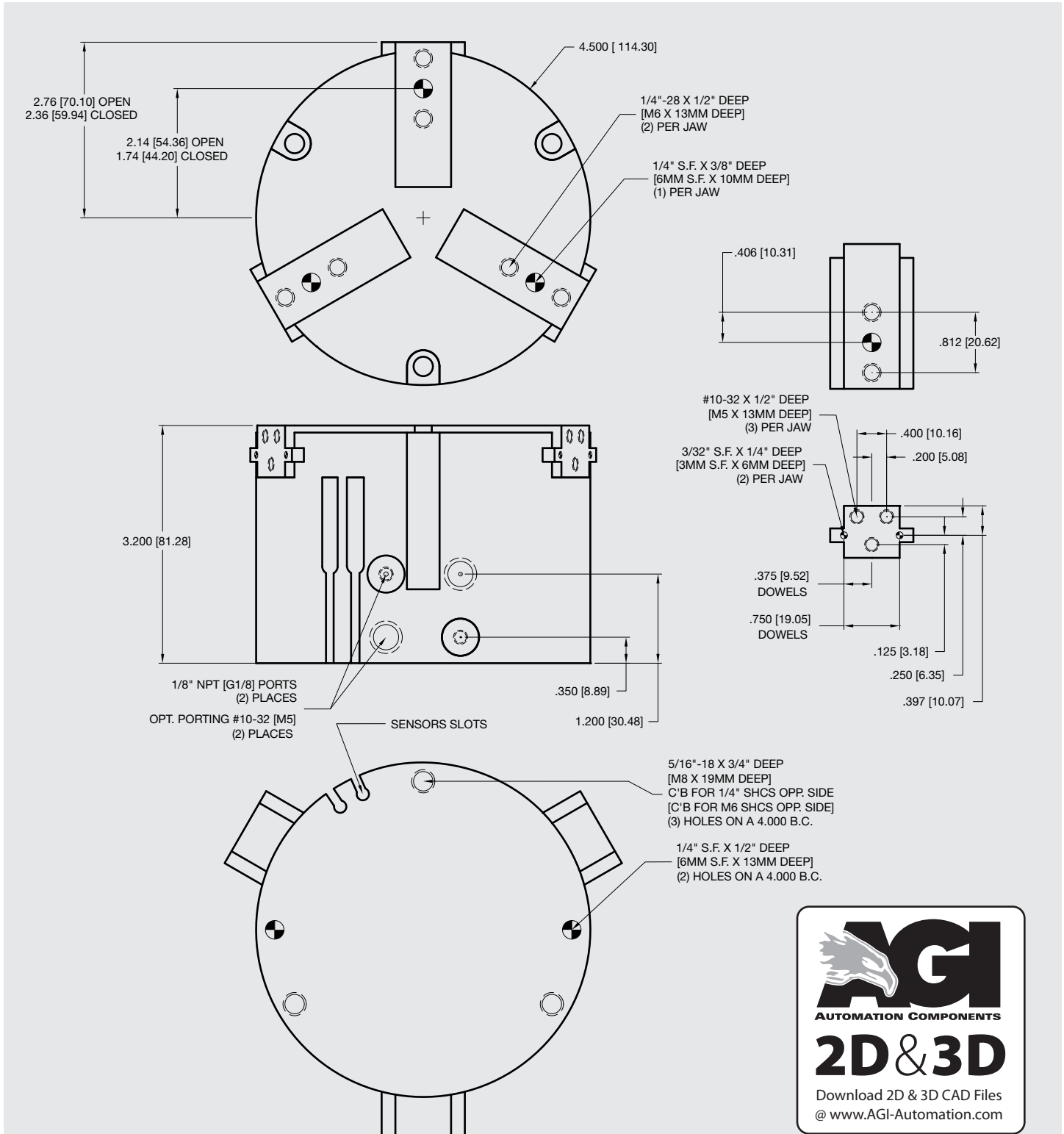

Unless noted, all tolerances are as indicated here:

	All Dowel Holes are SF (Slip Fit) Locational Tolerance ± .0005" [.013mm]		Metric Threads Course Pitch	Imperial: 0.00 = ±.01 0.000 = ±.005 0.0000 = ±.0005	Metric: [.0] = ±.25 [0.0] = ±.13 [0.00] = ±.013
---	--	---	-----------------------------	---	---



AGM Gripper & Rotary Modules

Rotary Manifold, Ultra Low Profile, Zero Backlash Units



ADVANCED FEATURES AND BENEFITS

- Internal Porting of Motion Module thru a rotary manifold.
- This prevents airlines from twisting, rubbing and sagging outside the unit.
- The rotary manifold connects the gripper and rotary actuator.
- This yields a versatile automation module system for assembly.

PRODUCT DETAILS:

Multi-Motion Actuators provide linear and rotary motion from one unit. The grip-and-turn motions are independent from one another, making it easy to sequence the two motions. The Multi Motion Module yields a versatile automation module for part pick and place applications and orientation operations. Internal porting prevents airlines from twisting, snagging, and breaking outside the unit.

MODULE COMBINATIONS:

Rotary	+	Gripper	=	Part #
AGR-1-90	+	AGP-250	=	AGM-1
AGR-1-180	+	AGP-250	=	AGM-2
AGR-2-90	+	AGP-250	=	AGM-3
AGR-2-180	+	AGP-250	=	AGM-4
AGR-2-90	+	AGP-375	=	AGM-5
AGR-2-180	+	AGP-375	=	AGM-6
AGR-2-90	+	AGP-500	=	AGM-7
AGR-2-180	+	AGP-500	=	AGM-8
AGR-2-90	+	AGW-250	=	AGM-9
AGR-2-180	+	AGW-250	=	AGM-10
AGR-3-90-M	+	AGW-375-1	=	AGM-11
AGR-3-180 -M	+	AGW-375-1	=	AGM-12
AGR-3-90-M	+	AGW-375-2	=	AGM-13
AGR-3-180-M	+	AGW-375-2	=	AGM-14
AGR-3-90-M	+	AGW-375-4	=	AGM-15
AGR-3-180-M	+	AGW-375-4	=	AGM-16

A total of 80 possible combinations available online

For detailed product specifications and CAD drawings, please visit our website at www.AGI-Automation.com

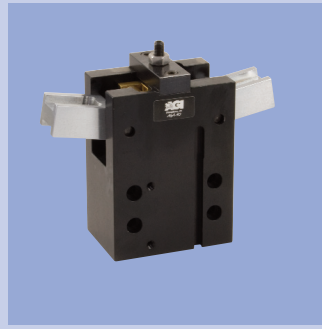

AGA Series

Angular Grippers





AGA-10 Angular Gripper

Double Guided, Low Profile



FEATURES AND BENEFITS

- Grippers provide up to 180° of angular jaw travel allowing the jaws to completely retract from the work area eliminating another required axis of travel.
- High gripping force to weight ratio.
- Compact design with long stroke.
- Jaw rotations can be adjusted from 0-90° to allow the gripper to be custom fit to each application.
- Units are permanently lubricated for non-lube air operation, allowing for compliance with OSHA regulation.
- Proximity sensors are available to monitor open and closed position of the jaws.
- AGA is fully field repairable for cost savings and minimum down time.
- The gripper body has two mounting surfaces with dowel pin holes to provide accurate mounting in a variety of positions.

SPECIFICATIONS

Design: Angular

Stroke: 0-180° adj

Gripping Force @ 80 PSI [5.5 BAR]

Closing: 20 lbs [88 N]
Opening: 22 lb [97 N]

Time:

Close: 0.2 sec [0.2 sec]
Open: 0.2 sec [0.2 sec]

Pressure Range:

Low/High 10-120 PSI [7-8 BAR]

Temperature Range:

Low/High -20°/180°F [-28°/80°C]

Side Play:

± 0.001 [.03 mm]

Repeatability from Center:

± 0.002 [.06 mm]

Loading Capacity:

	Static	Dynamic
Max Tensile T	22 lbs [100 N]	14 lbs [65 N]
Max Compressive C	22 lbs [100 N]	14 lbs [65 N]
Max Moment M_x	26 in/lb [3 Nm]	9 in/lb [1 Nm]
Max Moment M_y	26 in/lb [3 Nm]	9 in/lb [1 Nm]
Max Moment M_z	26 in/lb [3 Nm]	9 in/lb [1 Nm]

Material: High Strength, Hard Coated aluminum bronze alloys, Steel

Weight: XX oz [XX g]

Piston Diameter: 0.5 in [13 mm]

January 2009 - PATENTED Made in the USA

HOLDING FORCES CHART

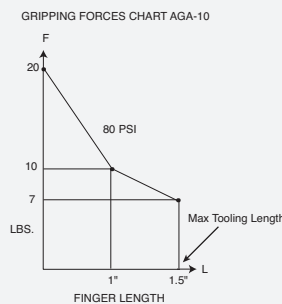

WARNING! Do not exceed tooling jaw length. See Chart above.

LOADING INFORMATION

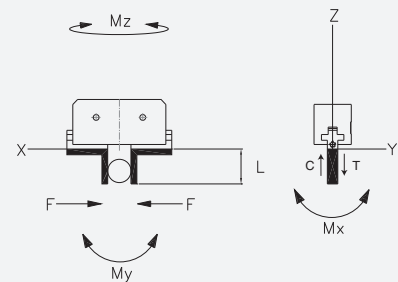

LOOK! More Technical specifications for sensors on "Sensors Accessories" page.

HOW TO ORDER

When ordering, please specify:
Design/Model Number and Options.

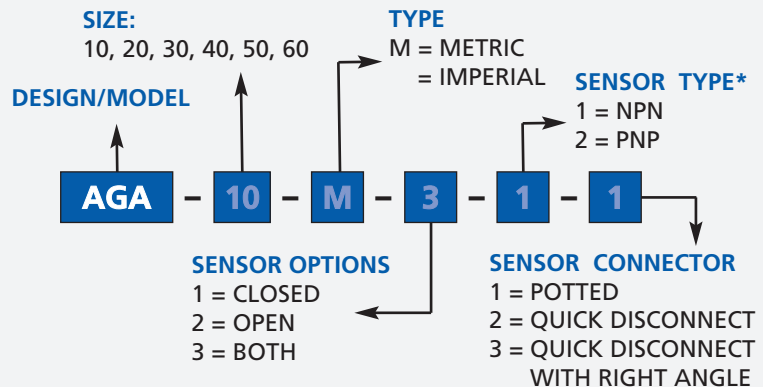

* NOTE: Hall Effect 4mm dia., 5-24 VDC, 22 mA and comes with 2 meter cable.

Sensor Part # SNQ04, SNC02, SPC02, SPQ04

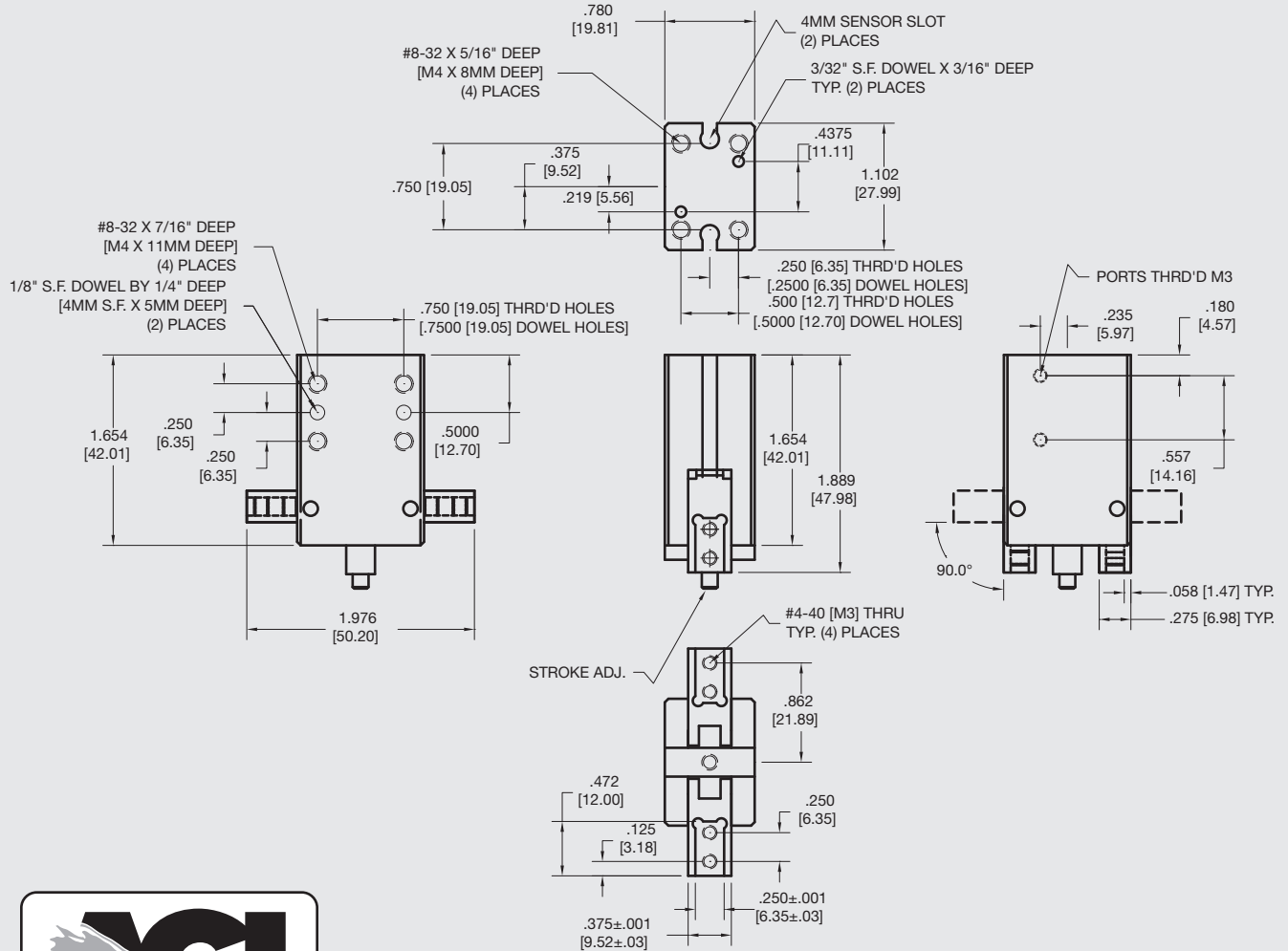

Unless noted, all tolerances are as indicated here:



All Dowel Holes are SF (Slip Fit) Locational Tolerance ± .0005" [0.13mm]



Metric Threads Course Pitch

Imperial:
Inch 0.00 = ±.01
0.000 = ±.005
0.0000 = ±.0005

Metric: [0.] = ±.25
[mm] [0.0] = ±.13
[0.00] = ±.013

AGA-20 Angular Gripper

Double Guided, Low Profile



FEATURES AND BENEFITS

- Grippers provide up to 180° of angular jaw travel allowing the jaws to completely retract from the work area eliminating another required axis of travel.
- High gripping force to weight ratio.
- Compact design with long stroke.
- Jaw rotations can be adjusted from 0-90° to allow the gripper to be custom fit to each application.
- Units are permanently lubricated for non-lube air operation, allowing for compliance with OSHA regulation.
- Proximity sensors are available to monitor open and closed position of the jaws.
- AGA is fully field repairable for cost savings and minimum down time.
- The gripper body has two mounting surfaces with dowel pin holes to provide accurate mounting in a variety of positions.

SPECIFICATIONS

Design: Angular

Stroke: 0-180° adj

Gripping Force @ 80 PSI [5.5 BAR]

Closing: 52 lbs [231 N]
Opening: 55 lb [245 N]

Time:

Close: 0.2 sec [0.2 sec]
Open: 0.2 sec [0.2 sec]

Pressure Range:

Low/High 10-120 PSI [7-8 BAR]

Temperature Range:

Low/High -20°/180°F [-28°/80°C]

Side Play: ± 0.001 [.03 mm]

Repeatability from Center: ± 0.002 [.06 mm]

Loading Capacity:

	Static	Dynamic
Max Tensile T	50 lbs [222 N]	20 lbs [89 N]
Max Compressive C	50 lbs [222 N]	20 lbs [89 N]

Max Moment M_x 60 in/lb [6.8 Nm] 20 in/lb [2.3 Nm]

Max Moment M_y 120 in/lb [13.6 Nm] 40 in/lb [4.5 Nm]

Max Moment M_z 60 in/lb [6.8 Nm] 20 in/lb [2.3 Nm]

Material: High Strength, Hard Coated aluminum bronze alloys, Steel

Weight: 7 oz [198 g]

Piston Diameter: 0.787 in [20 mm]

January 2009 - PATENTED Made in the USA

HOLDING FORCES CHART

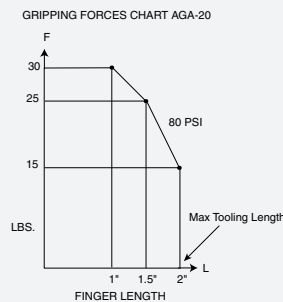

WARNING! Do not exceed tooling jaw length. See Chart above.

LOADING INFORMATION

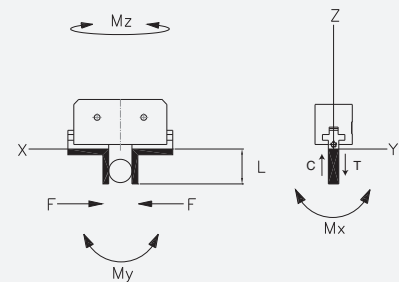

LOOK! More Technical specifications for sensors on "Sensors Accessories" page.

HOW TO ORDER

When ordering, please specify:
Design/Model Number and Options.

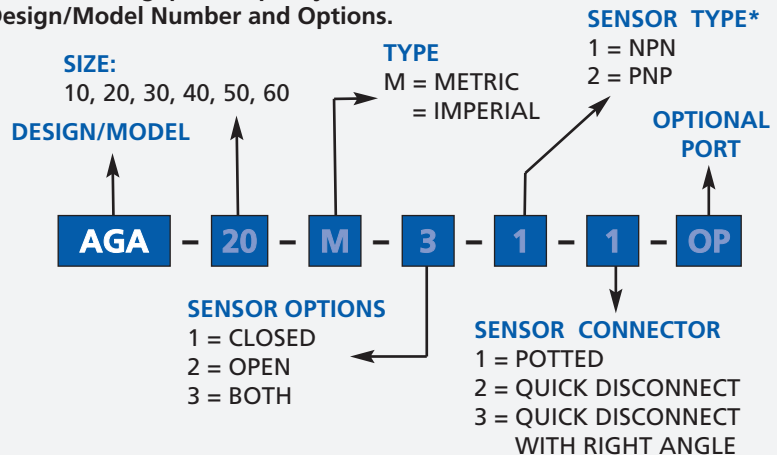

* NOTE: Hall Effect 4mm dia., 5-24 VDC, 22 mA and comes with 2 meter cable.

Sensor Part # SNQ04, SNC02, SPC02, SPQ04

AGA-20 Angular Gripper

Double Guided, Low Profile

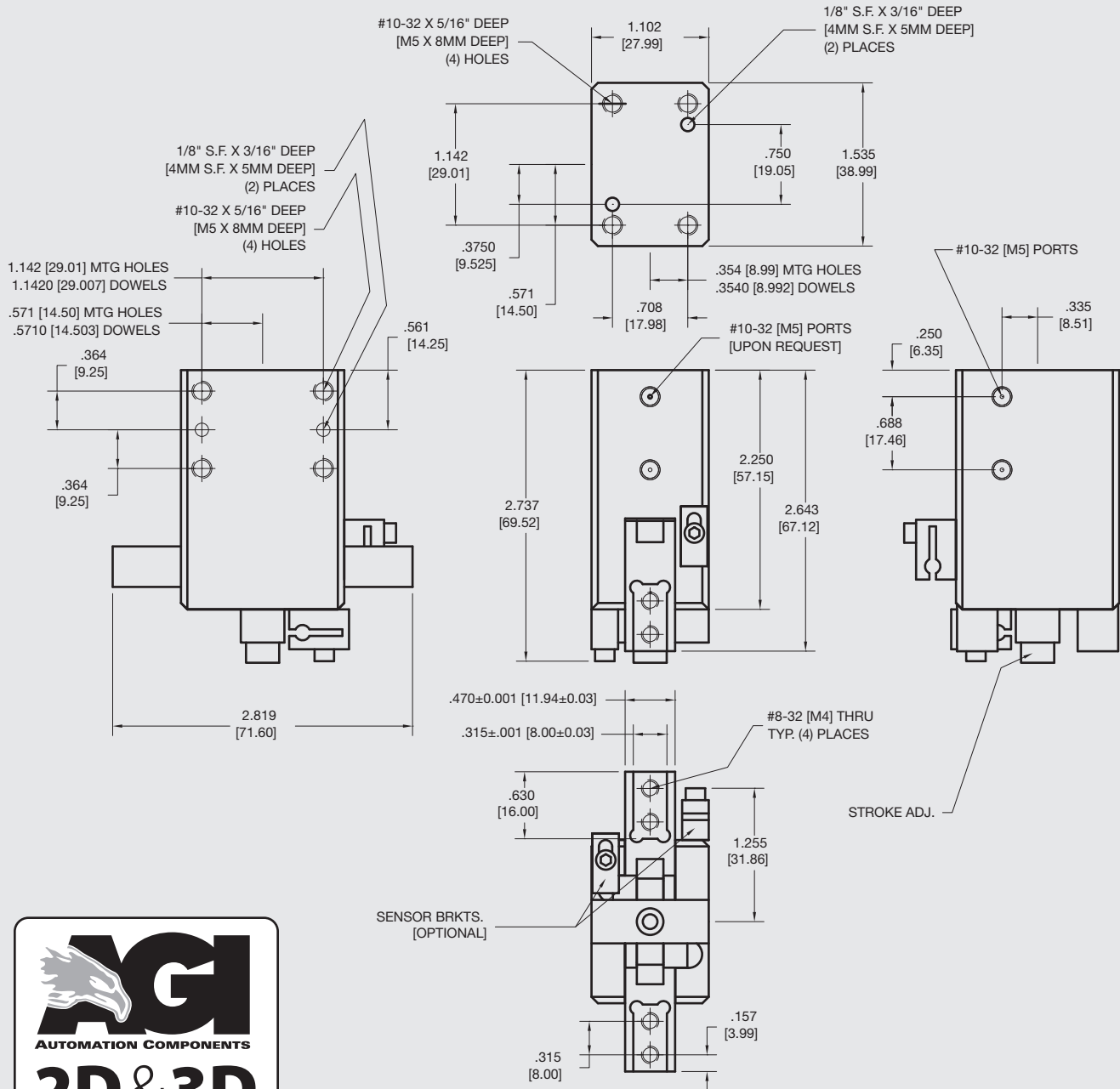

Unless noted, all tolerances are as indicated here:



All Dowel Holes are SF (Slip Fit) Locational Tolerance $\pm .0005"$ [0.13mm]



Metric Threads Course Pitch

Imperial:
Inch

0.00 = ± 0.01
0.000 = ± 0.005
0.0000 = ± 0.0005

Metric:
[mm]
[0.] = ± 0.25
[0.0] = ± 0.13
[0.00] = ± 0.13



AGA-30 Angular Gripper

Double Guided, Low Profile



FEATURES AND BENEFITS

- Grippers provide up to 180° of angular jaw travel allowing the jaws to completely retract from the work area eliminating another required axis of travel.
- High gripping force to weight ratio.
- Compact design with long stroke.
- Jaw rotations can be adjusted from 0-90° to allow the gripper to be custom fit to each application.
- Units are permanently lubricated for non-lube air operation, allowing for compliance with OSHA regulation.
- Proximity sensors are available to monitor open and closed position of the jaws.
- AGA is fully field repairable for cost savings and minimum down time.
- The gripper body has two mounting surfaces with dowel pin holes to provide accurate mounting in a variety of positions.

SPECIFICATIONS

Design: Angular

Stroke: 0-180° adj

Gripping Force @ 80 PSI [5.5 BAR]

Closing: 75 lbs [333 N]
Opening: 62 lbs [275 N]

Time:

Close: 0.2 sec [0.2 sec]
Open: 0.2 sec [0.2 sec]

Pressure Range:

Low/High 10-120 PSI [7-8 BAR]

Temperature Range:

Low/High -20°/180°F [-28°/80°C]

Side Play:

± 0.001 [.03 mm]

Repeatability from Center:

± 0.002 [.06 mm]

Loading Capacity:

	Static	Dynamic
Max Tensile T	60 lbs [266 N]	30 lbs [130 N]
Max Compressive C	60 lbs [266 N]	30 lbs [130 N]
Max Moment M_x	90 in/lb [10 Nm]	30 in/lb [3.4 Nm]
Max Moment M_y	140 in/lb [15.8 Nm]	35 in/lb [4 Nm]
Max Moment M_z	90 in/lb [10 Nm]	30 in/lb [3.4 Nm]

Material: High Strength, Hard Coated aluminum bronze alloys, Steel

Weight: 1.5 lbs [.7 kg]

Piston Diameter: 1.125 in [28.5 mm]

January 2009 - PATENTED Made in the USA

HOLDING FORCES CHART

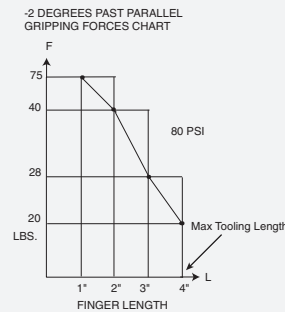

WARNING! Do not exceed tooling jaw length. See Chart above.

LOADING INFORMATION

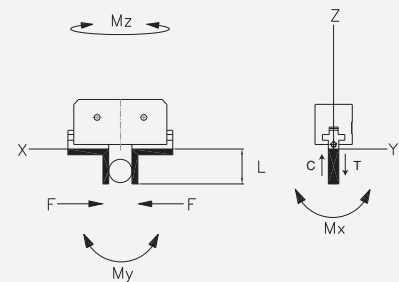

LOOK! More Technical specifications for sensors on "Sensors Accessories" page.

HOW TO ORDER

When ordering, please specify:
Design/Model Number and Options.

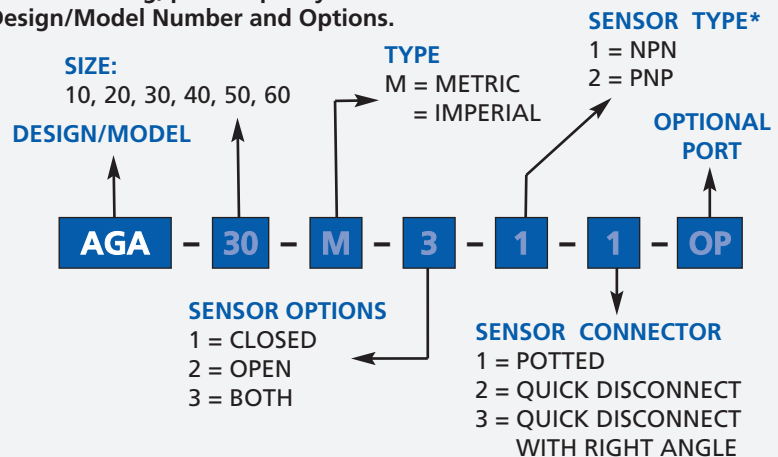

* NOTE: Hall Effect 4mm dia., 5-24 VDC, 22 mA and comes with 2 meter cable.

Sensor Part # SNQ04, SNC02, SPC02, SPQ04

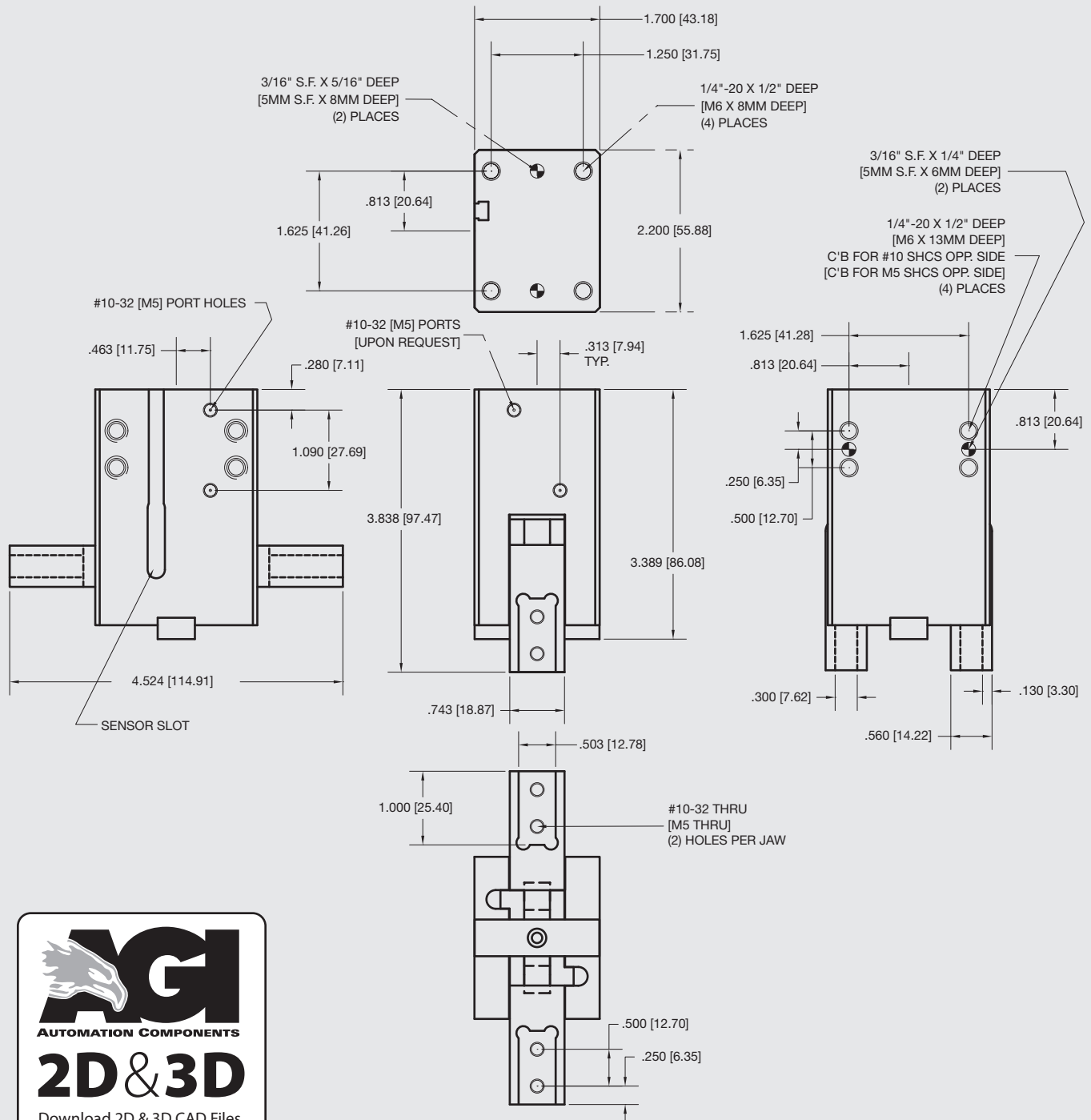

Unless noted, all tolerances are as indicated here:



All Dowel Holes are SF (Slip Fit) Locational Tolerance $\pm .0005"$ [.013mm]



Metric Threads Course Pitch

Imperial:
Inch 0.00 = $\pm .01$
0.000 = $\pm .005$
0.0000 = $\pm .0005$

Metric: [0.] = $\pm .25$
[0.0] = $\pm .13$
[0.00] = $\pm .013$



AGA-40 Angular Gripper

Double Guided, Low Profile



FEATURES AND BENEFITS

- Grippers provide up to 180° of angular jaw travel allowing the jaws to completely retract from the work area eliminating another required axis of travel.
- High gripping force to weight ratio.
- Compact design with long stroke.
- Jaw rotations can be adjusted from 0-90° to allow the gripper to be custom fit to each application.
- Units are permanently lubricated for non-lube air operation, allowing for compliance with OSHA regulation.
- Proximity sensors are available to monitor open and closed position of the jaws.
- AGA is fully field repairable for cost savings and minimum down time.
- The gripper body has two mounting surfaces with dowel pin holes to provide accurate mounting in a variety of positions.

SPECIFICATIONS

Design: Angular

Stroke: 0-180° adj

Gripping Force @ 80 PSI [5.5 BAR]

Closing: 180 lbs [800 N]
 Opening: 168 lbs [747 N]

Time:

Close: 0.2 sec [0.2 sec]
 Open: 0.2 sec [0.2 sec]

Pressure Range:

Low/High 10-120 PSI [7-8 BAR]

Temperature Range:

Low/High -20°/180°F [-28°/80°C]

Side Play: ± 0.001 [.03 mm]

Repeatability from Center: ± 0.002 [.06 mm]

Loading Capacity:

	Static	Dynamic
Max Tensile T	90 lbs [400 N]	40 lbs [177 N]
Max Compressive C	90 lbs [400 N]	40 lbs [177 N]

Max Moment M_x 150 in/lb [17 Nm] 430 in/lb [4.5 Nm]

Max Moment M_y 180 in/lb [20.3 Nm] 45 in/lb [5 Nm]

Max Moment M_z 150 in/lb [17 Nm] 40 in/lb [4.5 Nm]

Material: High Strength, Hard Coated aluminum bronze alloys, Steel

Weight: 2.25 lbs [1 kg]

Piston Diameter: 1.5 in [38 mm]

January 2009 - PATENTED Made in the USA

HOLDING FORCES CHART

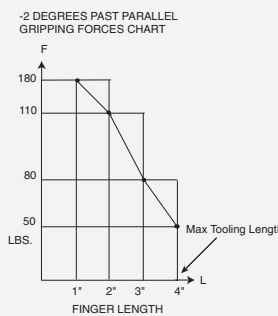

WARNING! Do not exceed tooling jaw length. See Chart above.

LOADING INFORMATION

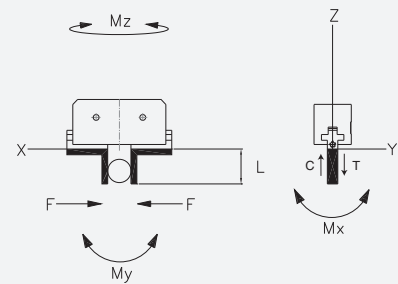

LOOK! More Technical specifications for sensors on "Sensors Accessories" page.

HOW TO ORDER

When ordering, please specify:
 Design/Model Number and Options.

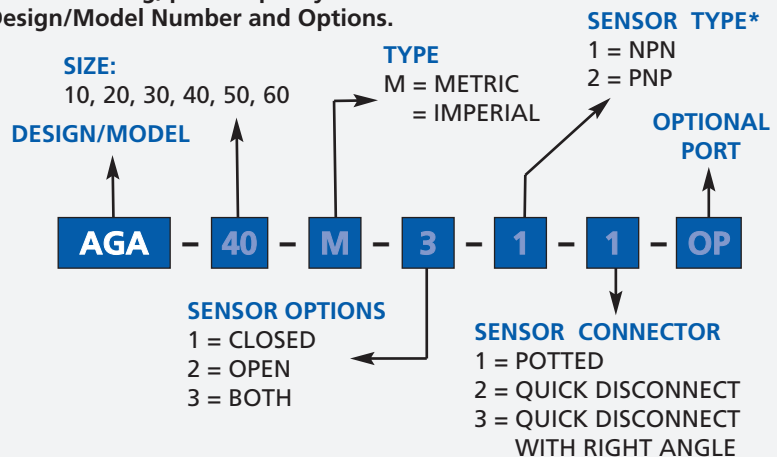

* NOTE: Hall Effect 4mm dia., 5-24 VDC, 22 mA and comes with 2 meter cable.

Sensor Part # SNQ04, SNC02, SPC02, SPQ04

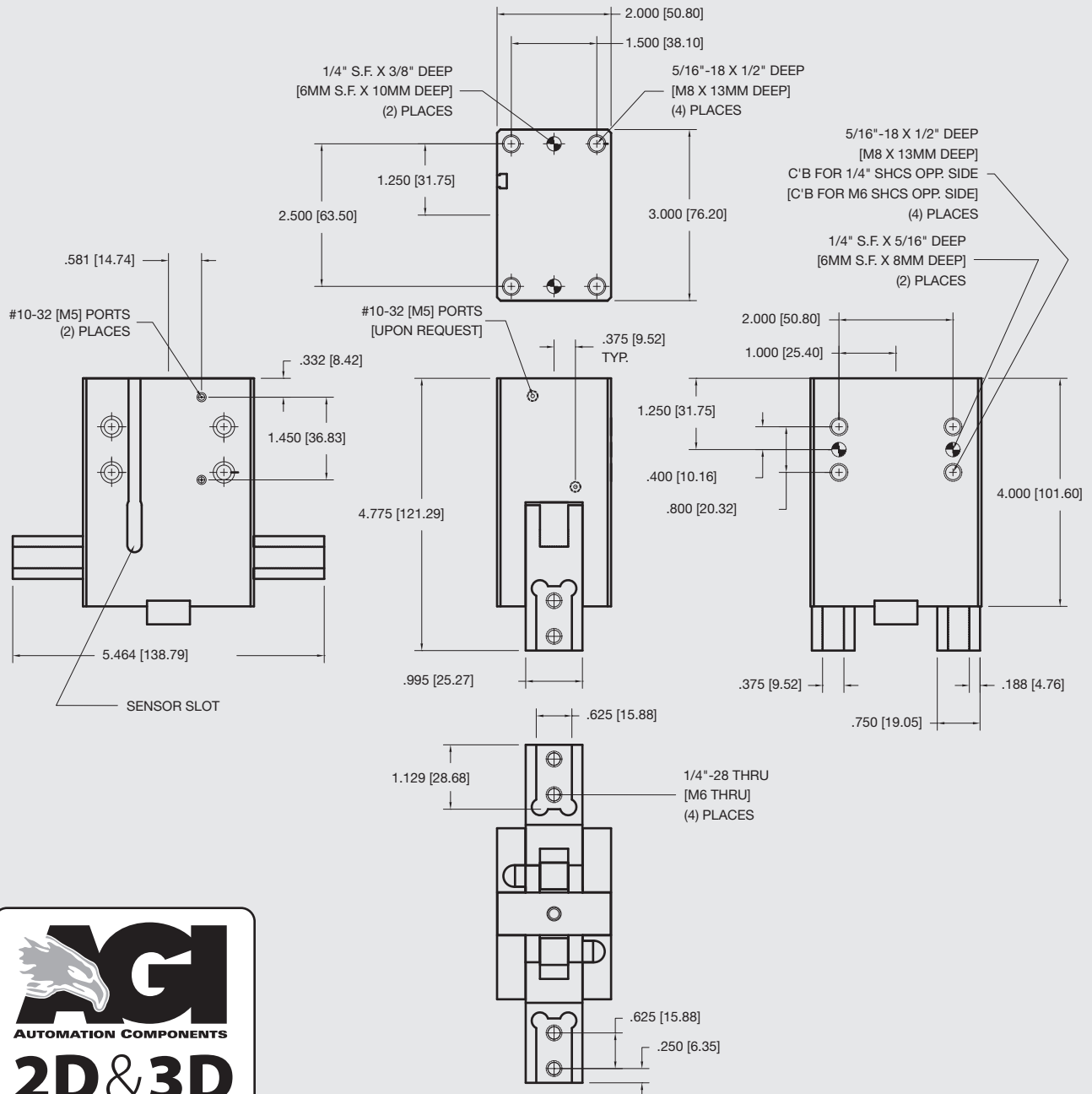

Unless noted, all tolerances are as indicated here:



All Dowel Holes are SF (Slip Fit) Locational Tolerance $\pm .0005"$ [0.13mm]



Metric Threads Course Pitch

Imperial:
Inch 0.00 = $\pm .01$
0.000 = $\pm .005$
0.0000 = $\pm .0005$

Metric: [0.] = $\pm .25$
[mm] [0.0] = $\pm .13$
[0.00] = $\pm .013$



AGA-50 Angular Gripper

Double Guided, Low Profile



FEATURES AND BENEFITS

- Grippers provide up to 180° of angular jaw travel allowing the jaws to completely retract from the work area eliminating another required axis of travel.
- High gripping force to weight ratio.
- Compact design with long stroke.
- Jaw rotations can be adjusted from 0-90° to allow the gripper to be custom fit to each application.
- Units are permanently lubricated for non-lube air operation, allowing for compliance with OSHA regulation.
- Proximity sensors are available to monitor open and closed position of the jaws.
- AGA is fully field repairable for cost savings and minimum down time.
- The gripper body has two mounting surfaces with dowel pin holes to provide accurate mounting in a variety of positions.

SPECIFICATIONS

Design: Angular

Stroke: 0-180° adj

Gripping Force @ 80 PSI [5.5 BAR]

Closing: 720 lbs [3200 N]
 Opening: 685 lbs [3050 N]

Time:

Close: 0.2 sec [0.2 sec]
 Open: 0.2 sec [0.2 sec]

Pressure Range:

Low/High 10-120 PSI [7-8 BAR]

Temperature Range:

Low/High -20°/180°F [-28°/80°C]

Side Play: ± 0.001 [.03 mm]

Repeatability from Center: ± 0.002 [.06 mm]

Loading Capacity:

	Static	Dynamic
Max Tensile T	1200 lbs [5330 N]	400 lbs [1780 N]
Max Compressive C	1200 lbs [5330 N]	400 lbs [1780 N]
Max Moment M_x	930 in/lb [105 Nm]	310 in/lb [35 Nm]
Max Moment M_y	880 in/lb [20.3 Nm]	276 in/lb [31.2 Nm]
Max Moment M_z	880 in/lb [99.5 Nm]	276 in/lb [31.2 Nm]

Material: High Strength, Hard Coated aluminum bronze alloys, Steel

Weight: 5.5 lbs [2.3 kg]
Piston Diameter: 2.25 in [57.2 mm]

January 2009 - PATENTED Made in the USA

HOLDING FORCES CHART

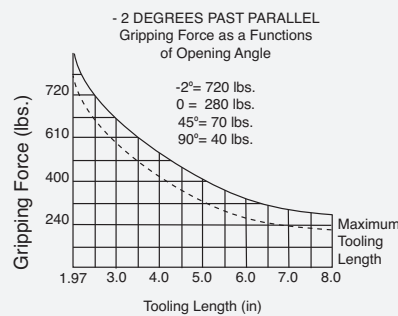

WARNING! Do not exceed tooling jaw length. See Chart above.

LOADING INFORMATION

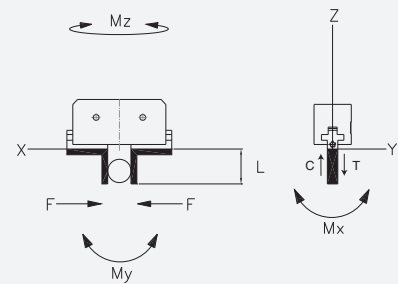

LOOK! More Technical specifications for sensors on "Sensors Accessories" page.

HOW TO ORDER

When ordering, please specify:
 Design/Model Number and Options.

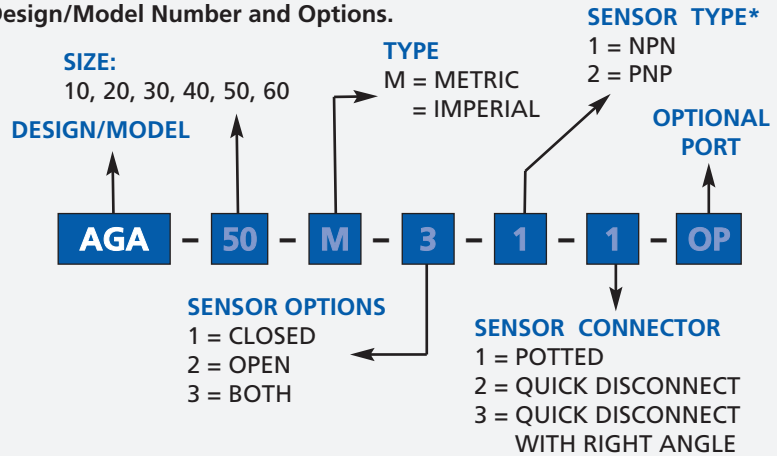

* NOTE: Hall Effect 4mm dia., 5-24 VDC, 22 mA and comes with 2 meter cable.

Sensor Part # SNQ04, SNC02, SPC02, SPQ04

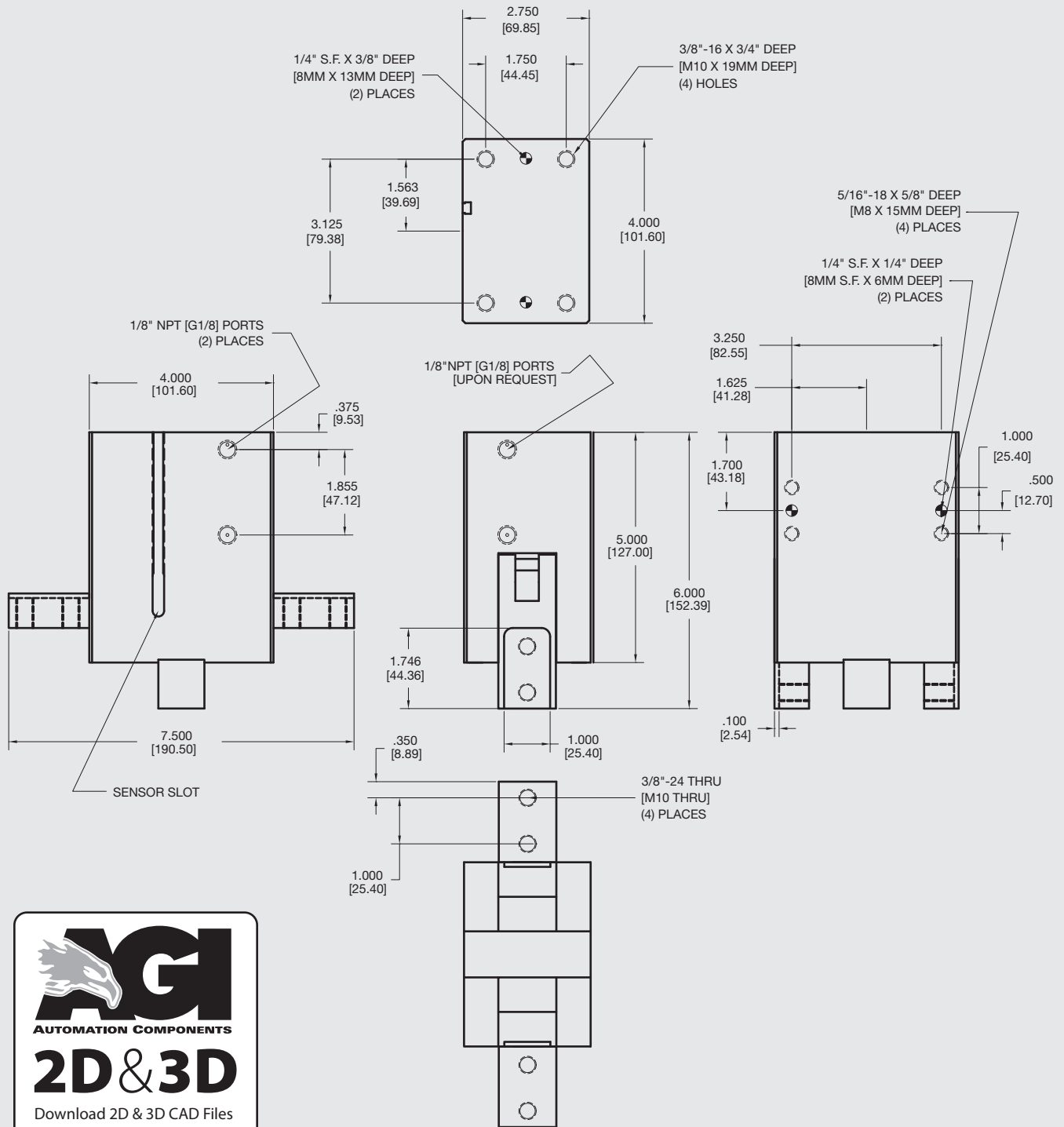

Unless noted, all tolerances are as indicated here:



All Dowel Holes are SF (Slip Fit) Locational Tolerance $\pm .0005"$ [.013mm]



Metric Threads Course Pitch

Imperial:
Inch 0.00 = $\pm .01$
0.000 = $\pm .005$
0.0000 = $\pm .0005$

Metric: [0.] = $\pm .25$
[mm] [0.0] = $\pm .13$
[0.00] = $\pm .013$



AGA-60 Angular Gripper

Double Guided, Low Profile

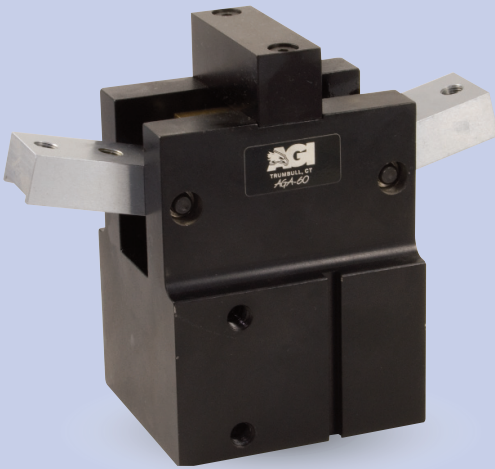

FEATURES AND BENEFITS

- Grippers provide up to 180° of angular jaw travel allowing the jaws to completely retract from the work area eliminating another required axis of travel.
- High gripping force to weight ratio.
- Compact design with long stroke.
- Jaw rotations can be adjusted from 0-90° to allow the gripper to be custom fit to each application.
- Units are permanently lubricated for non-lube air operation, allowing for compliance with OSHA regulation.
- Proximity sensors are available to monitor open and closed position of the jaws.
- AGA is fully field repairable for cost savings and minimum down time.
- The gripper body has two mounting surfaces with dowel pin holes to provide accurate mounting in a variety of positions.

SPECIFICATIONS

Design: Angular

Stroke: 0-180° adj

Gripping Force @ 80 PSI [5.5 BAR]

Closing: 820 lbs [3600 N]
Opening: 691 lbs [3070 N]

Time:

Close: 0.5 sec [0.5 sec]
Open: 0.5 sec [0.5 sec]

Pressure Range:

Low/High 10-120 PSI [7-8 BAR]

Temperature Range:

Low/High -20°/180°F [-28°/80°C]

Side Play: ± 0.001 [.03 mm]

Repeatability from Center: ± 0.002 [.06 mm]

Loading Capacity:

	Static	Dynamic
Max Tensile T	1200 lbs [5330 N]	400 lbs [1780 N]
Max Compressive C	1200 lbs [5330 N]	400 lbs [1780 N]

Max Moment M_x 930 in/lb [105 Nm] 310 in/lb [35 Nm]

Max Moment M_y 880 in/lb [99.5 Nm] 276 in/lb [31.2 Nm]

Max Moment M_z 880 in/lb [99.5 Nm] 276 in/lb [31.2 Nm]

Material: High Strength, Hard Coated aluminum bronze alloys, Steel

Weight: 6 lbs [2.7 kg]

Piston Diameter: 3.0 in [76 mm]

January 2009 - PATENTED Made in the USA

HOLDING FORCES CHART

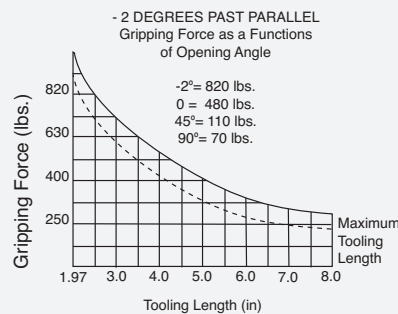

WARNING! Do not exceed tooling jaw length. See Chart above.

LOADING INFORMATION

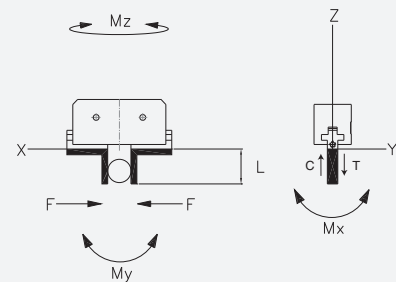

LOOK! More Technical specifications for sensors on "Sensors Accessories" page.

HOW TO ORDER

When ordering, please specify:
Design/Model Number and Options.

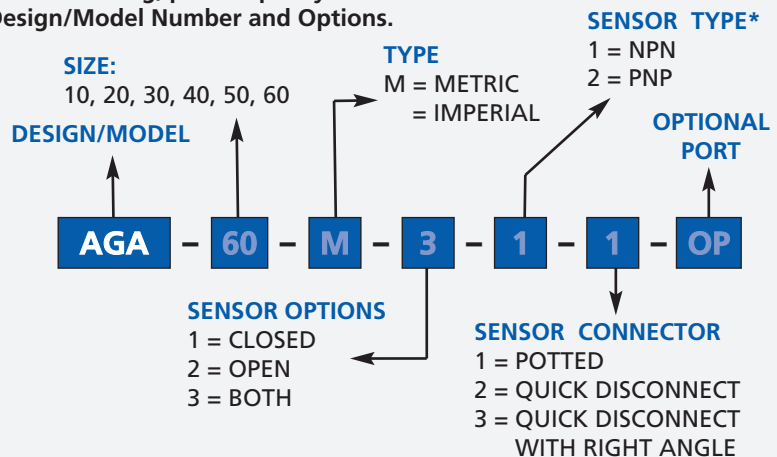

* NOTE: Hall Effect 4mm dia., 5-24 VDC, 22 mA and comes with 2 meter cable.

Sensor Part # SNQ04, SNC02, SPC02, SPQ04

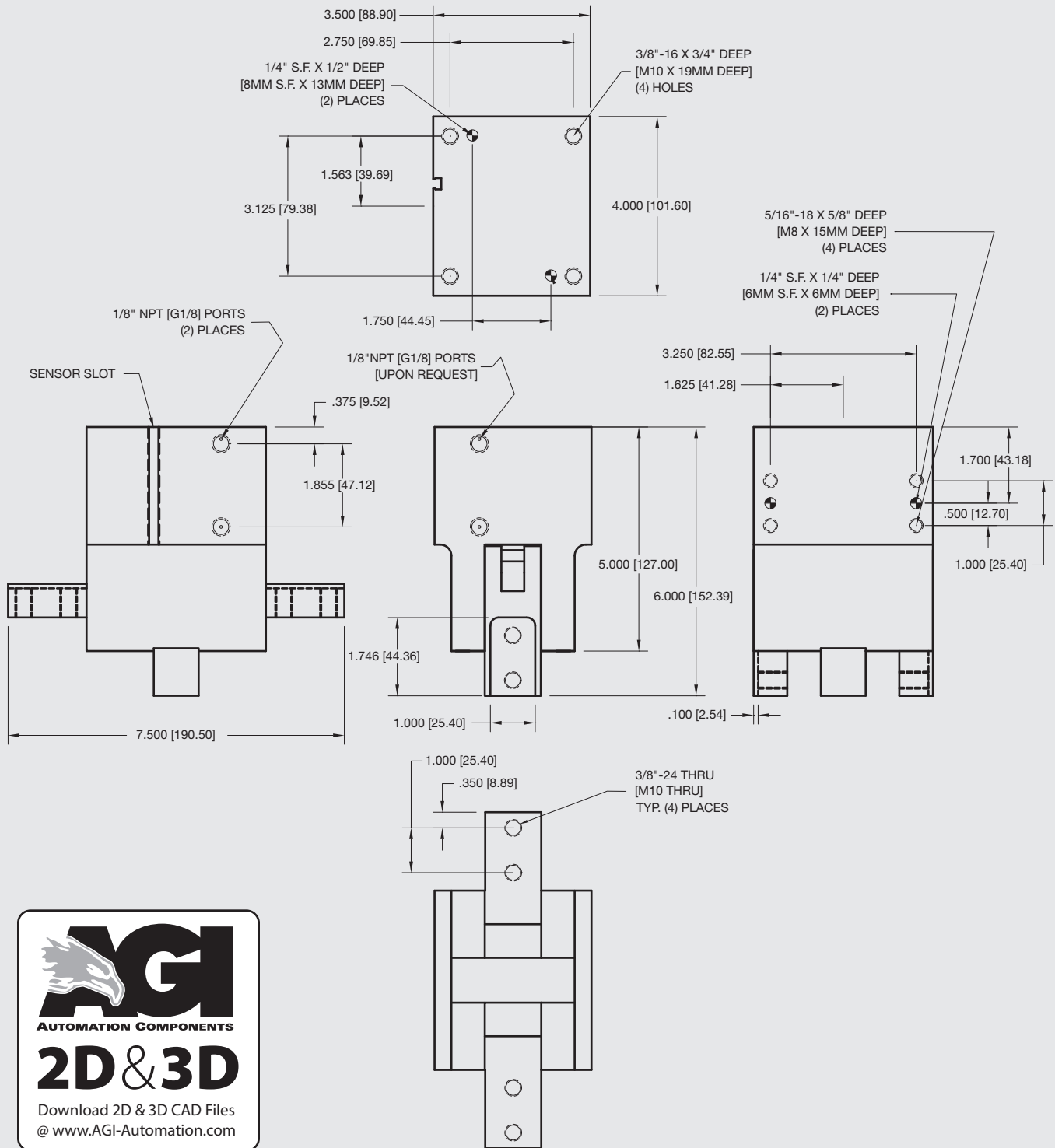

Unless noted, all tolerances are as indicated here:



All Dowel Holes are SF (Slip Fit) Locational Tolerance $\pm .0005"$ [.013mm]



Metric Threads Course Pitch

Imperial:
Inch 0.00 = $\pm .01$
0.000 = $\pm .005$
0.0000 = $\pm .0005$

Metric: [0.] = $\pm .25$
[mm] [0.0] = $\pm .13$
[0.00] = $\pm .013$



AGA-23 Angular Gripper

180° Three Jaw



FEATURES AND BENEFITS

- Grippers provide up to 180° of angular jaw travel allowing the jaws to completely retract from the work area eliminating another required axis of travel.
- High gripping force to weight ratio.
- Compact design with long, adjustable stroke.
- Jaw rotations can be adjusted from 0-90° to allow the gripper to be custom fit to each application.
- Units are permanently lubricated for non-lube air operation, allowing for compliance with OSHA regulation.
- Proximity sensors are available to monitor open and closed position of the jaws.
- AGA is fully field repairable for cost savings and minimum down time.
- The gripper body has two mounting surfaces with dowel pin holes to provide accurate mounting in a variety of positions.

SPECIFICATIONS

Design: 3-Jaw Angular

Stroke: 0-180° adjustable

Gripping Force @ 80 PSI [5.5 BAR]

Closing: 17 lbs [75 N]
Opening: 20 lb [89 N]

Time:

Close: 0.2 sec [0.2 sec]
Open: 0.2 sec [0.2 sec]

Pressure Range:

Low/High 10-120 PSI [7-8 BAR]

Temperature Range:

Low/High -20°/180°F [-28°/80°C]

Side Play: ± 0.001 [.03 mm]

Repeatability from Center: ± 0.002 [.06 mm]

Loading Capacity:

	Static	Dynamic
Max Tensile T	50 lbs [222 N]	20 lbs [89 N]
Max Compressive C	50 lbs [222 N]	20 lbs [89 N]

Max Moment M_x 60 in/lb [6.8 Nm] 20 in/lb [2.3 Nm]

Max Moment M_y 120 in/lb [13.6 Nm] 40 in/lb [4.5 Nm]

Max Moment M_z 60 in/lb [6.8 Nm] 20 in/lb [2.3 Nm]

Material: High Strength, Hard Coated aluminum bronze alloys, Steel

Weight: 1.0 lb [0.45 kg]

Piston Diameter: 0.787 in [20 mm]

January 2009 - PATENTED Made in the USA

HOLDING FORCES CHART

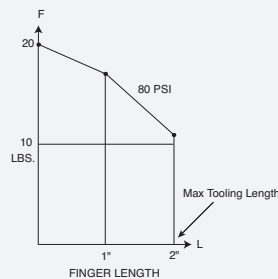

WARNING! Do not exceed tooling jaw length. See Chart above.

LOADING INFORMATION

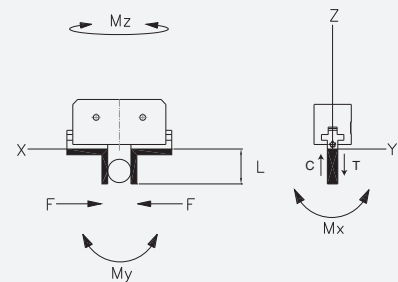

LOOK! More Technical specifications for sensors on "Sensors Accessories" page.

HOW TO ORDER

When ordering, please specify:
Design/Model Number and Options.

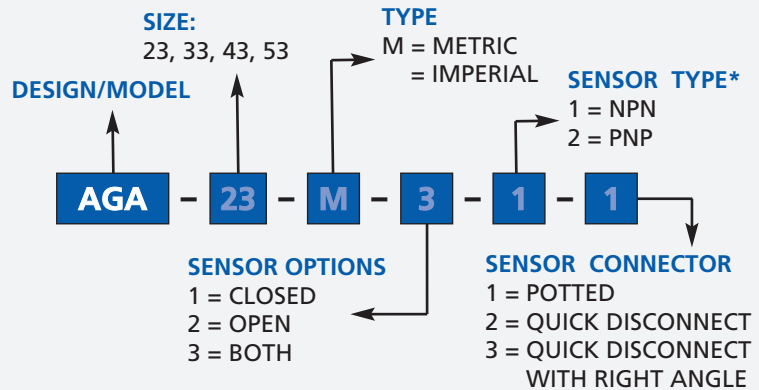

* NOTE: Hall Effect 4mm dia., 5-24 VDC, 22 mA and comes with 2 meter cable.

Sensor Part # SNQ04, SNC02, SPC02, SPQ04

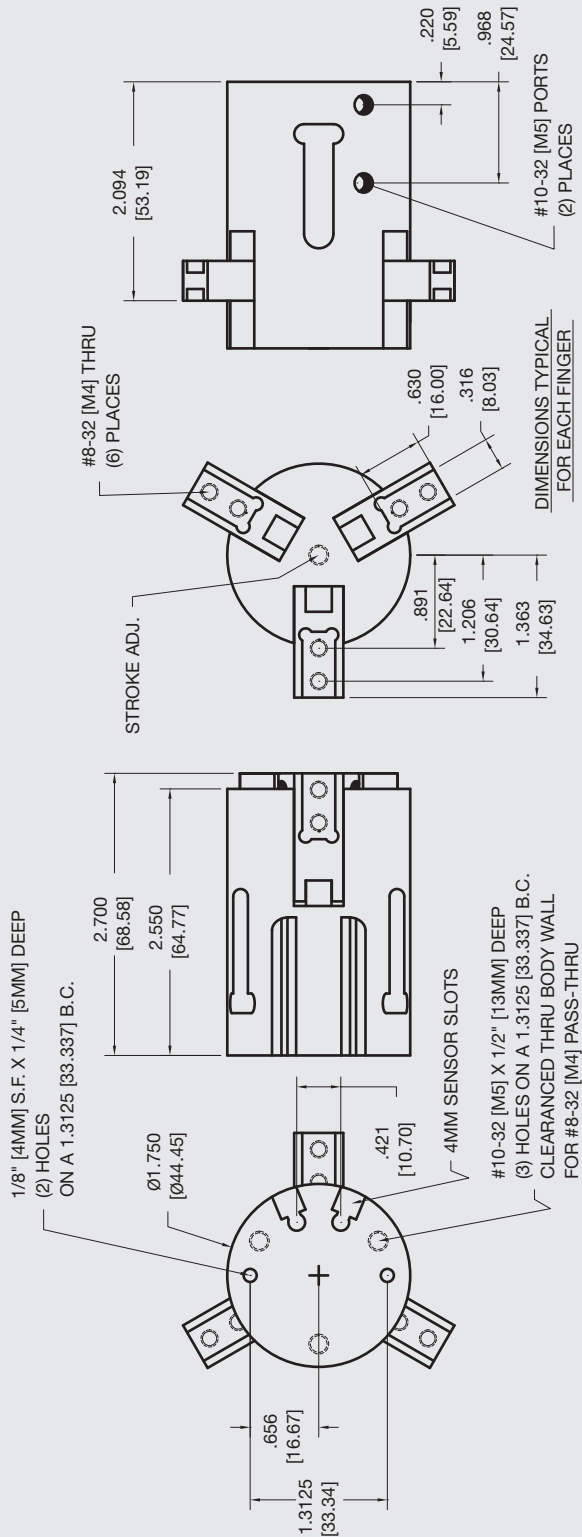

Unless noted, all tolerances are as indicated here:



All Dowel Holes are SF (Slip Fit) Locational Tolerance $\pm .0005"$ [0.13mm]



Metric Threads Course Pitch

Imperial:
Inch 0.00 = $\pm .01$
0.000 = $\pm .005$
0.0000 = $\pm .0005$

Metric: [0.] = $\pm .25$
[0.0] = $\pm .13$
[0.00] = $\pm .013$

AGA-33 Angular Gripper

180° Three Jaw



FEATURES AND BENEFITS

- Grippers provide up to 180° of angular jaw travel allowing the jaws to completely retract from the work area eliminating another required axis of travel.
- High gripping force to weight ratio.
- Compact design with long, adjustable stroke.
- Jaw rotations can be adjusted from 0-90° to allow the gripper to be custom fit to each application.
- Units are permanently lubricated for non-lube air operation, allowing for compliance with OSHA regulation.
- Proximity sensors are available to monitor open and closed position of the jaws.
- AGA is fully field repairable for cost savings and minimum down time.
- The gripper body has two mounting surfaces with dowel pin holes to provide accurate mounting in a variety of positions.

SPECIFICATIONS

Design: 3-Jaw Angular

Stroke: 0-180° adjustable

Gripping Force @ 80 PSI [5.5 BAR]

Closing: 26 lbs [115 N]
Opening: 22 lbs [97 N]

Time:

Close: 0.3 sec [0.3 sec]
Open: 0.3 sec [0.3 sec]

Pressure Range:

Low/High 10-120 PSI [7-8 BAR]

Temperature Range:

Low/High -20°/180°F [-28°/80°C]

Side Play: ± 0.001 [.03 mm]

Repeatability from Center: ± 0.002 [.06 mm]

Loading Capacity:

	Static	Dynamic
Max Tensile T	60 lbs [266 N]	30 lbs [130 N]
Max Compressive C	60 lbs [266 N]	30 lbs [130 N]

Max Moment M_x 90 in/lb [10 Nm] 30 in/lb [3.4 Nm]

Max Moment M_y 140 in/lb [15.8 Nm] 35 in/lb [4 Nm]

Max Moment M_z 90 in/lb [10 Nm] 30 in/lb [3.4 Nm]

Material: High Strength, Hard Coated aluminum bronze alloys, Steel

Weight: 2 lbs [1 kg]

Piston Diameter: 1.125 in [28.5 mm]

January 2009 - PATENTED Made in the USA

HOLDING FORCES CHART

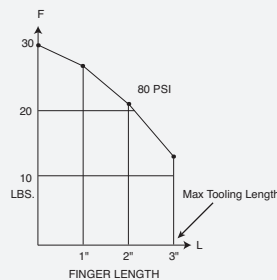

WARNING! Do not exceed tooling jaw length. See Chart above.

LOADING INFORMATION

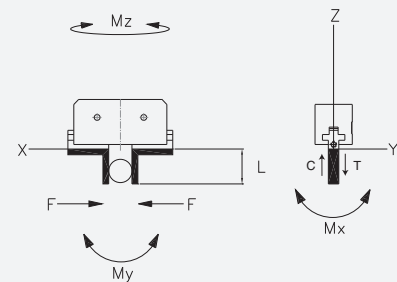

LOOK! More Technical specifications for sensors on "Sensors Accessories" page.

HOW TO ORDER

When ordering, please specify:
Design/Model Number and Options.

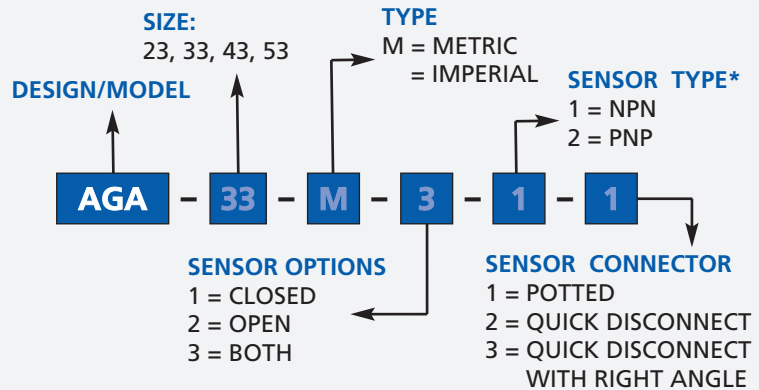

* NOTE: Hall Effect 4mm dia., 5-24 VDC, 22 mA and comes with 2 meter cable.

Sensor Part # SNQ04, SNC02, SPC02, SPQ04

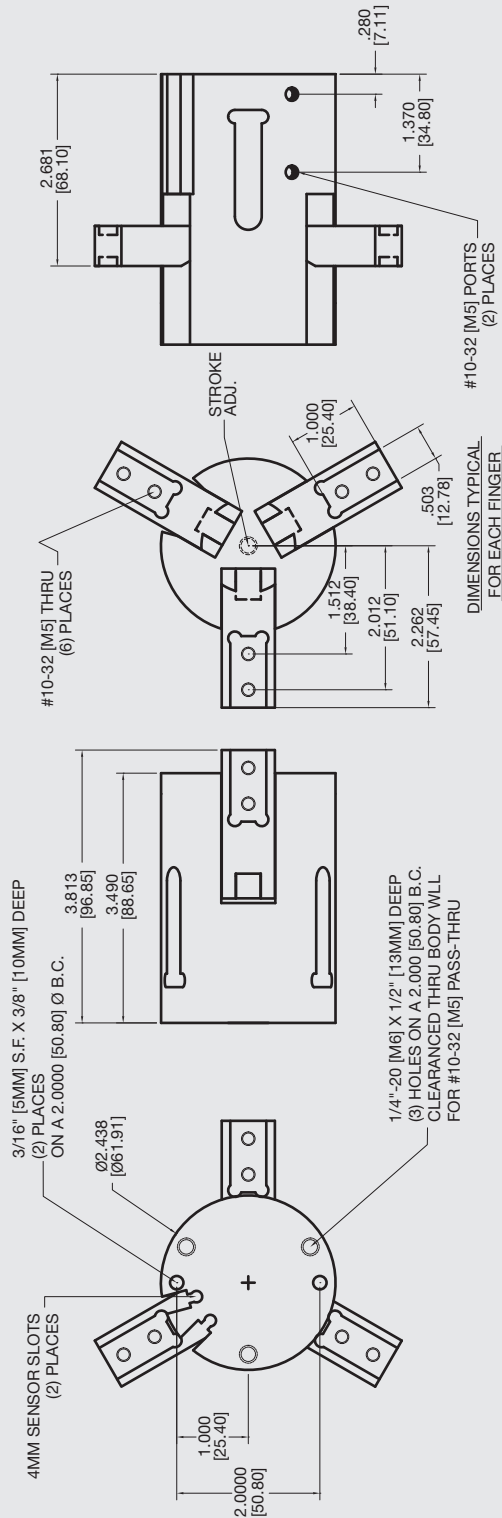

Unless noted, all tolerances are as indicated here:



All Dowel Holes are SF (Slip Fit) Locational Tolerance $\pm .0005"$ [0.13mm]



Metric Threads Course Pitch

Imperial:
Inch 0.00 = ± 0.1
0.000 = ± 0.005
0.0000 = ± 0.0005

Metric: [0.] = ± 0.25
[0.0] = ± 0.13
[0.00] = ± 0.13



AGA-43 Angular Gripper

180° Three Jaw



FEATURES AND BENEFITS

- Grippers provide up to 180° of angular jaw travel allowing the jaws to completely retract from the work area eliminating another required axis of travel.
- High gripping force to weight ratio.
- Compact design with long, adjustable stroke.
- Jaw rotations can be adjusted from 0-90° to allow the gripper to be custom fit to each application.
- Units are permanently lubricated for non-lube air operation, allowing for compliance with OSHA regulation.
- Proximity sensors are available to monitor open and closed position of the jaws.
- AGA is fully field repairable for cost savings and minimum down time.
- The gripper body has two mounting surfaces with dowel pin holes to provide accurate mounting in a variety of positions.

SPECIFICATIONS

Design: 3-Jaw Angular

Stroke: 0-180° adjustable

Gripping Force @ 80 PSI [5.5 BAR]

Closing: 60 lbs [266 N]
Opening: 55 lbs [244 N]

Time:

Close: 0.4 sec [0.4 sec]
Open: 0.4 sec [0.4 sec]

Pressure Range:

Low/High 10-120 PSI [7-8 BAR]

Temperature Range:

Low/High -20°/180°F [-28°/80°C]

Side Play: ± 0.001 [.03 mm]

Repeatability from Center: ± 0.002 [.06 mm]

Loading Capacity:

	Static	Dynamic
Max Tensile T	90 lbs [400 N]	40 lbs [177 N]
Max Compressive C	90 lbs [400 N]	40 lbs [177 N]

Max Moment M_x 150 in/lb [17 Nm] 430 in/lb [4.5 Nm]

Max Moment M_y 180 in/lb [20.3 Nm] 45 in/lb [5 Nm]

Max Moment M_z 150 in/lb [17 Nm] 40 in/lb [4.5 Nm]

Material: High Strength, Hard Coated aluminum bronze alloys, Steel

Weight: 3.5 lbs [1.6 kg]

Piston Diameter: 1.5 in [38 mm]

January 2009 - PATENTED Made in the USA

HOLDING FORCES CHART

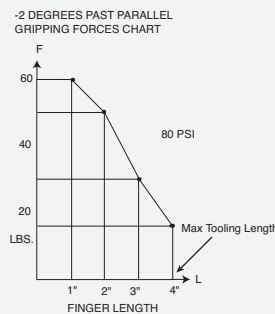

WARNING! Do not exceed tooling jaw length. See Chart above.

LOADING INFORMATION

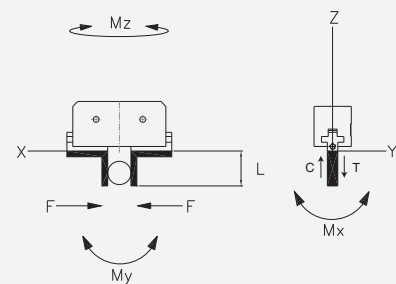

LOOK! More Technical specifications for sensors on "Sensors Accessories" page.

HOW TO ORDER

When ordering, please specify:
Design/Model Number and Options.

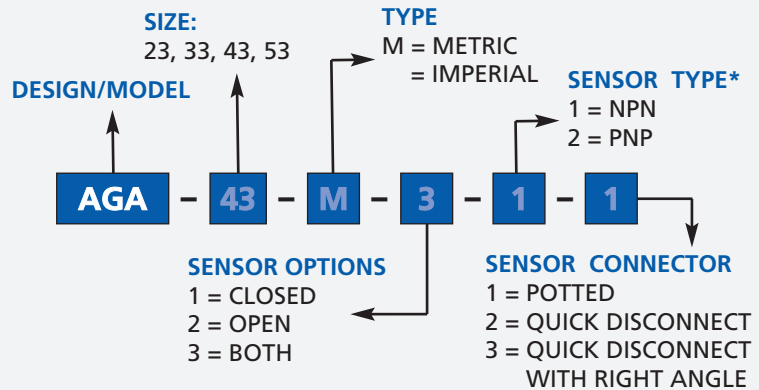

* NOTE: Hall Effect 4mm dia., 5-24 VDC, 22 mA and comes with 2 meter cable.

Sensor Part # SNQ04, SNC02, SPC02, SPQ04

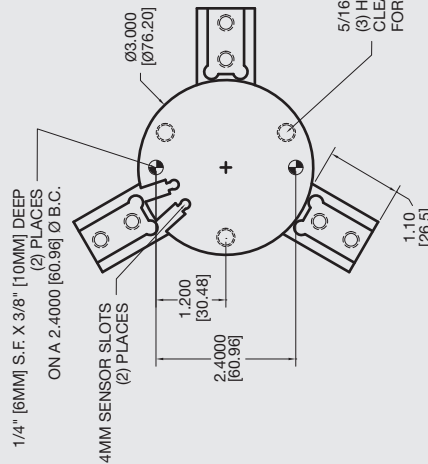
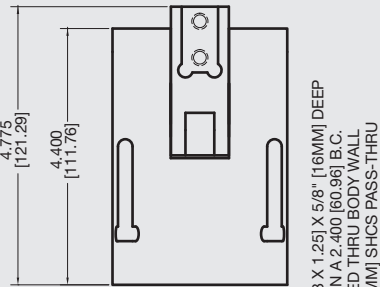
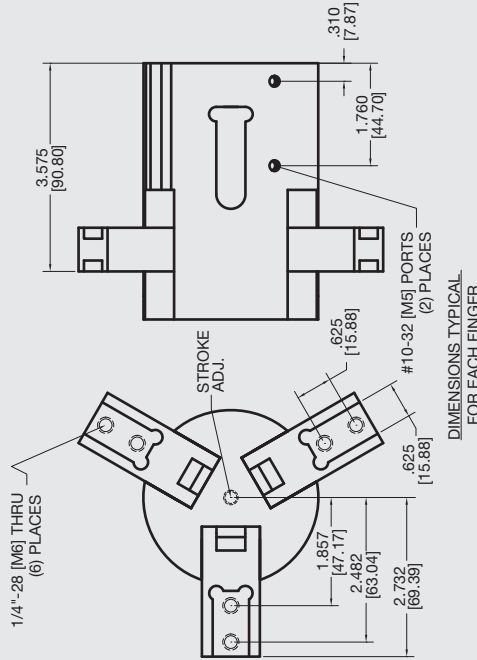

Unless noted, all tolerances are as indicated here:



All Dowel Holes are SF (Slip Fit) Locational Tolerance $\pm .0005"$ [0.13mm]



Metric Threads Course Pitch

Imperial:
Inch 0.00 = ± 0.01
0.000 = ± 0.005
0.0000 = ± 0.0005

Metric: [0.] = ± 0.25
[0.0] = ± 0.13
[0.00] = ± 0.13



AGA-53 Angular Gripper

180° Three Jaw



FEATURES AND BENEFITS

- Grippers provide up to 180° of angular jaw travel allowing the jaws to completely retract from the work area eliminating another required axis of travel.
- High gripping force to weight ratio.
- Compact design with long, adjustable stroke.
- Jaw rotations can be adjusted from 0-90° to allow the gripper to be custom fit to each application.
- Units are permanently lubricated for non-lube air operation, allowing for compliance with OSHA regulation.
- Proximity sensors are available to monitor open and closed position of the jaws.
- AGA is fully field repairable for cost savings and minimum down time.
- The gripper body has two mounting surfaces with dowel pin holes to provide accurate mounting in a variety of positions.

SPECIFICATIONS

Design: 3-Jaw Angular

Stroke: 0-180° adjustable

Gripping Force @ 80 PSI [5.5 BAR]

Closing: 200 lbs [888 N]
Opening: 170 lbs [758 N]

Time:

Close: 0.4 sec [0.4 sec]
Open: 0.4 sec [0.4 sec]

Pressure Range:

Low/High 10-120 PSI [7-8 BAR]

Temperature Range:

Low/High -20°/180°F [-28°/80°C]

Side Play: ± 0.001 [.03 mm]

Repeatability from Center: ± 0.002 [.06 mm]

Loading Capacity:

	Static	Dynamic
Max Tensile T	1200 lbs [5330 N]	400 lbs [1780 N]
Max Compressive C	1200 lbs [5330 N]	400 lbs [1780 N]

Max Moment M_x 930 in/lb [105 Nm] 310 in/lb [35 Nm]

Max Moment M_y 880 in/lb [99.5 Nm] 276 in/lb [31.2 Nm]

Max Moment M_z 880 in/lb [99.5 Nm] 276 in/lb [31.2 Nm]

Material: High Strength, Hard Coated aluminum bronze alloys, Steel

Weight: 8 lbs [3.6 kg]

Piston Diameter: 2.25 in [57.2 mm]

January 2009 - PATENTED Made in the USA

HOLDING FORCES CHART

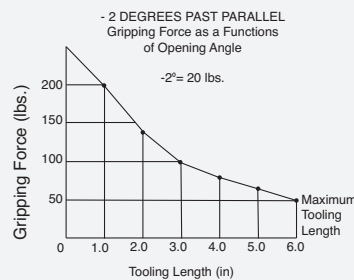

WARNING! Do not exceed tooling jaw length. See Chart above.

LOADING INFORMATION

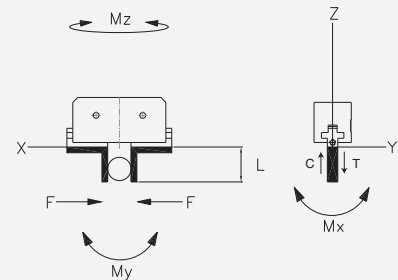

LOOK! More Technical specifications for sensors on "Sensors Accessories" page.

HOW TO ORDER

When ordering, please specify:
Design/Model Number and Options.

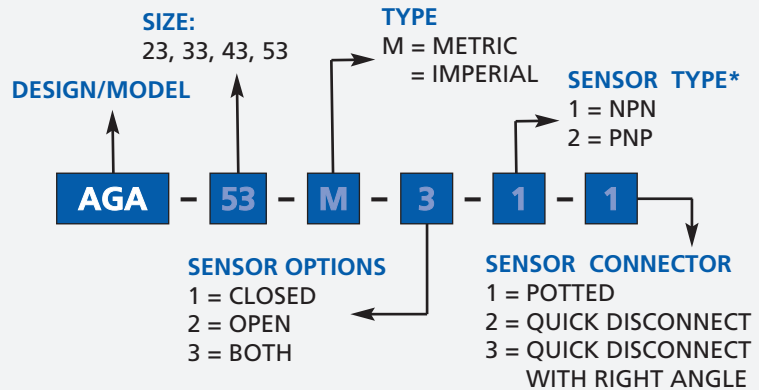

* NOTE: Hall Effect 4mm dia., 5-24 VDC, 22 mA and comes with 2 meter cable.

Sensor Part # SNQ04, SNC02, SPC02, SPQ04

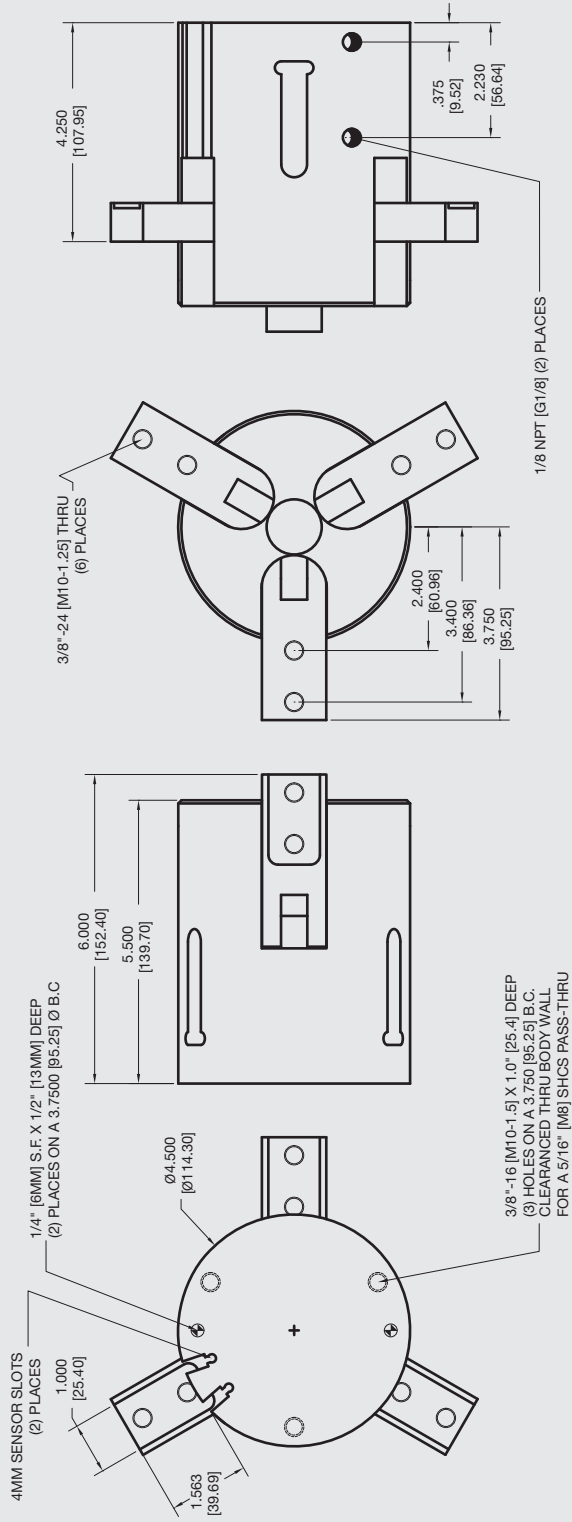

AGI
AUTOMATION COMPONENTS
2D & 3D
Download 2D & 3D CAD Files
@ www.AGI-Automation.com

Unless noted, all tolerances are as indicated here:



All Dowel Holes are SF (Slip Fit) Locational Tolerance ± .0005" [0.13mm]



Metric Threads Course Pitch

Imperial:
Inch 0.00 = ±.01
0.000 = ±.005
0.0000 = ±.0005

Metric: [0.] = ±.25
[mm] [0.0] = ±.13
[0.00] = ±.013

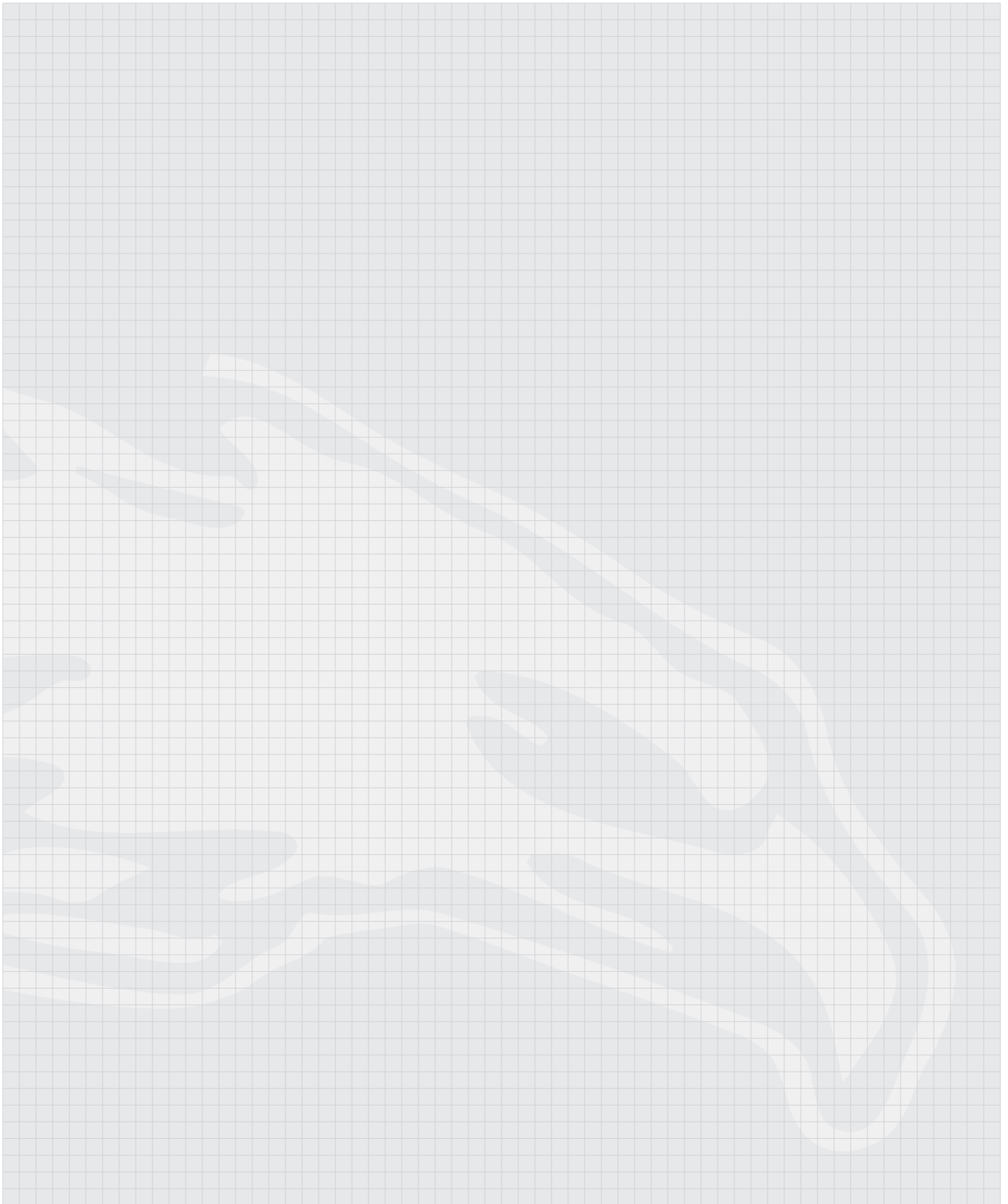

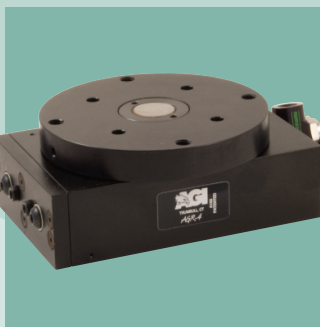
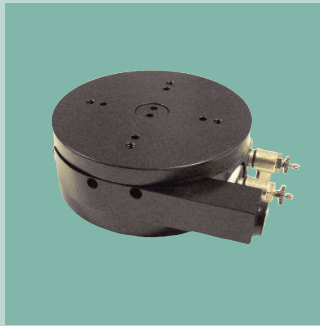

AGR Series

Rotaries





AGR-1 Rotary Actuator

Low Profile, Zero Backlash



FEATURES AND BENEFITS

- Built in adjustable hardstops on output flange stops against a dowel pin imbedded in the body to prevent pinion breakage, and give accurate specific rotation requirements.
- Two large bearings, one on either side of the pinion, provides for steady output flange with high loading capacity.
- Ultra high torque to weight ratio for faster cycle times.
- Compact body design to fit into tight space applications.
- Units are permanently lubricated for non-lube air operation, allowing compliance with OSHA regulations.
- All rotary units have zero backlash at either end of rotation, this keeps the output flange against the hard stop.
- Built in adjustable flow controls allow for maximum cycle times and smooth deceleration.
- Proximity switches are available to monitor end of rotation.
- The AGR unit is fully repairable for cost savings and minimum down time.

SPECIFICATIONS

Design: Rack and Pinion with Flange Hard Stop

Rotation Range: 0°-180° (Adj. +/- 5°)

Payload: 1 lb central to axis of rotation [.44 Kg]

Torque:
@80 psi [5.5 BAR] 5 in/lb [.56 Nm]

Bearing Load:
Dynamic 198 lbs [880 N]
Static 385 lbs [1620 N]

Rotation Time: No load .1 second

Pressure Range:
Low/High 30-120 PSI [2-8 BAR]

Temperature Range:
Low/High -20°/180°F [-28°/80°C]

Backlash: Zero

Accuracy: .001 concentric and perpendicular to axis of rotation

Material: High Strength, Hard Coated Aluminum Alloys, Steel

Weight: 7 oz [198 g]

Piston Diameter: (2x) .5 in [12.7 mm]

January 2009 - PATENTED Made in the USA

LOADING CAPACITY

	Static	Dynamic
Max Tensile T	50 lbs [222 N]	12 lbs [53 N]
Max Compressive C	250 lbs [1110 N]	50 lbs [222 N]
Max Moment M_x	100 in/lb [11.3 Nm]	25 in/lb [2.8 Nm]
Max Moment M_y	100 in/lb [11.3 Nm]	25 in/lb [2.8 Nm]

LOADING INFORMATION

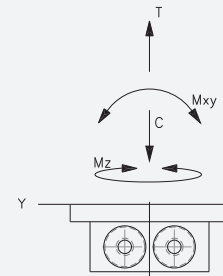

LOOK! More Technical specifications for sensors on "Sensors Accessories" page.

HOW TO ORDER

When ordering, please specify:
Design/Model Number and Options.

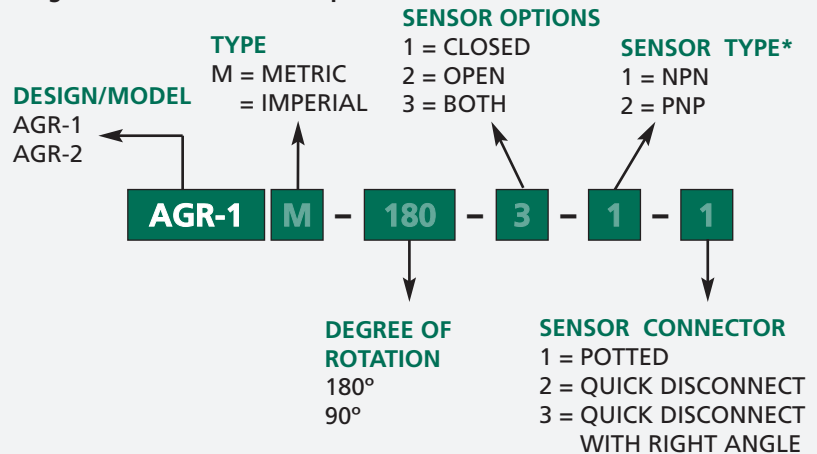

* NOTE: Proximity 4mm dia., 5-24 VDC, 22 mA and comes with 2 meter cable.

Sensor Part # SPC05, SPQ05, SNC05, SNQ05

AGR-1 Rotary Actuator

Low Profile, Zero Backlash

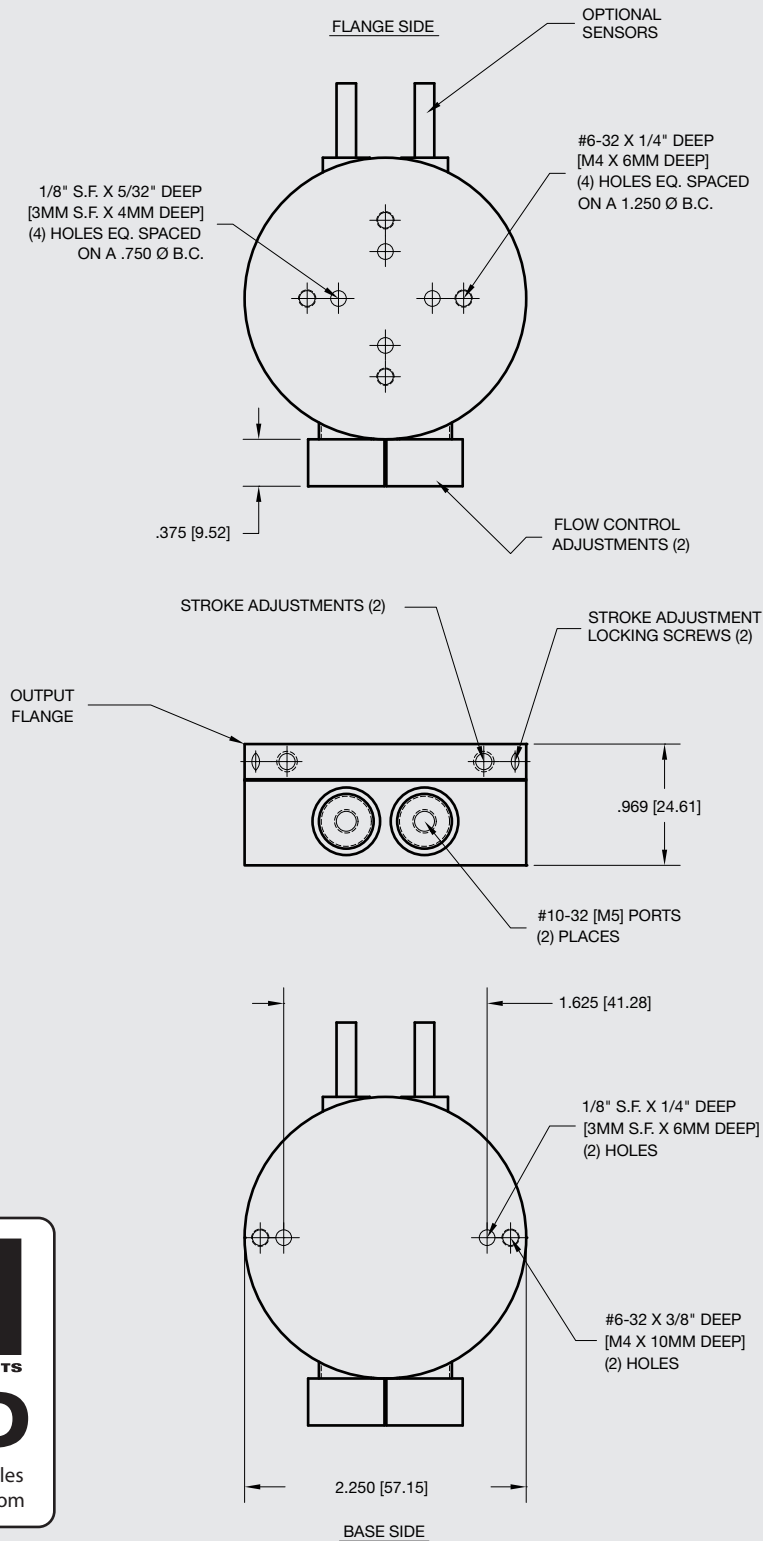

Unless noted, all tolerances are as indicated here:



All Dowel Holes are SF (Slip Fit) Locational Tolerance $\pm .0005$ " [.013mm]



Metric Threads Course Pitch

Imperial: 0.00 = $\pm .01$
0.000 = $\pm .005$
0.0000 = $\pm .0005$

Metric: [0.] = $\pm .25$
[mm] [0.0] = $\pm .13$
[0.00] = $\pm .013$



AGR-2 Rotary Actuator

Low Profile, Zero Backlash



FEATURES AND BENEFITS

- Built in adjustable hardstops on output flange stops against a dowel pin imbedded in the body to prevent pinion breakage, and give accurate specific rotation requirements.
- Two large bearings, one on either side of the pinion, provides for steady output flange with high loading capacity.
- Ultra high torque to weight ratio for faster cycle times.
- Compact body design to fit into tight space applications.
- Units are permanently lubricated for non-lube air operation, allowing compliance with OSHA regulations.
- All rotary units have zero backlash at either end of rotation, this keeps the output flange against the hard stop.
- Built in adjustable flow controls allow for maximum cycle times and smooth deceleration.
- Proximity switches are available to monitor end of rotation.
- The AGR unit is fully repairable for cost savings and minimum down time.

SPECIFICATIONS

Design: Rack and Pinion with Flange Hard Stop

Rotation Range: 0°-180° (Adj. +/- 5°)

Payload: 3 lbs central to axis of rotation [1.4 Kg]

Torque:
@80 psi [5.5 BAR] 17 in/lb [1.9 Nm]

Bearing Load:
Dynamic 198 lbs [880 N]
Static 385 lbs [1620 N]

Rotation Time: No load .2 second

Pressure Range:
Low/High 30-120 PSI [2-8 BAR]

Temperature Range:
Low/High -20°/180°F [-28°/80°C]

Backlash: Zero

Accuracy: .001 concentric and perpendicular to axis of rotation

Material: High Strength, Hard Coated Aluminum Alloys, Steel

Weight: 1.2 lb [1.2 kg]

Piston Diameter: (2x) .75 in [19 mm]

January 2009 - PATENTED Made in the USA

LOADING CAPACITY

	Static	Dynamic
Max Tensile T	75 lbs [333 N]	20 lbs [88 N]
Max Compressive C	350 lbs [1550 N]	75 lbs [333 N]
Max Moment M_x	200 in/lb [22.6 Nm]	50 in/lb [5.6 Nm]
Max Moment M_y	200 in/lb [22.6 Nm]	50 in/lb [5.6 Nm]

LOADING INFORMATION

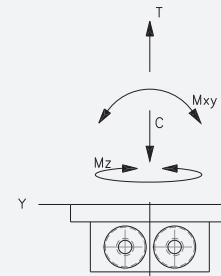

LOOK! More Technical specifications for sensors on "Sensors Accessories" page.

HOW TO ORDER

When ordering, please specify:
Design/Model Number and Options.

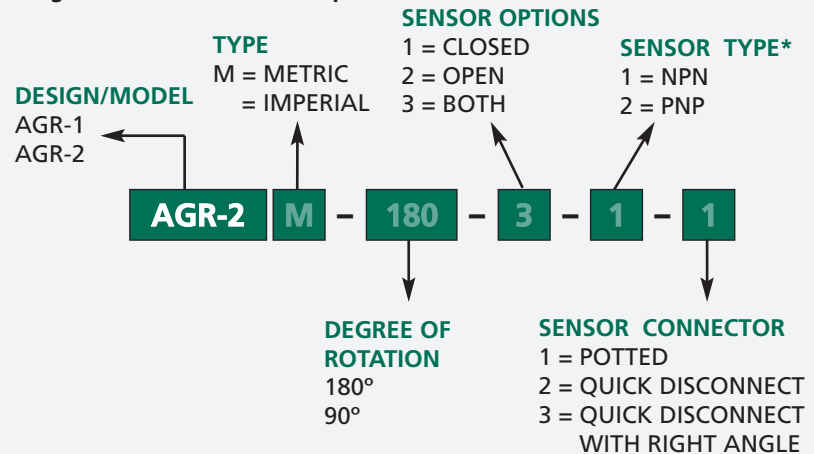

* NOTE: Proximity 4mm dia., 5-24 VDC, 22 mA and comes with 2 meter cable.

Sensor Part # SPC05, SPQ05, SNC05, SNQ05

AGR-2 Rotary Actuator

Low Profile, Zero Backlash

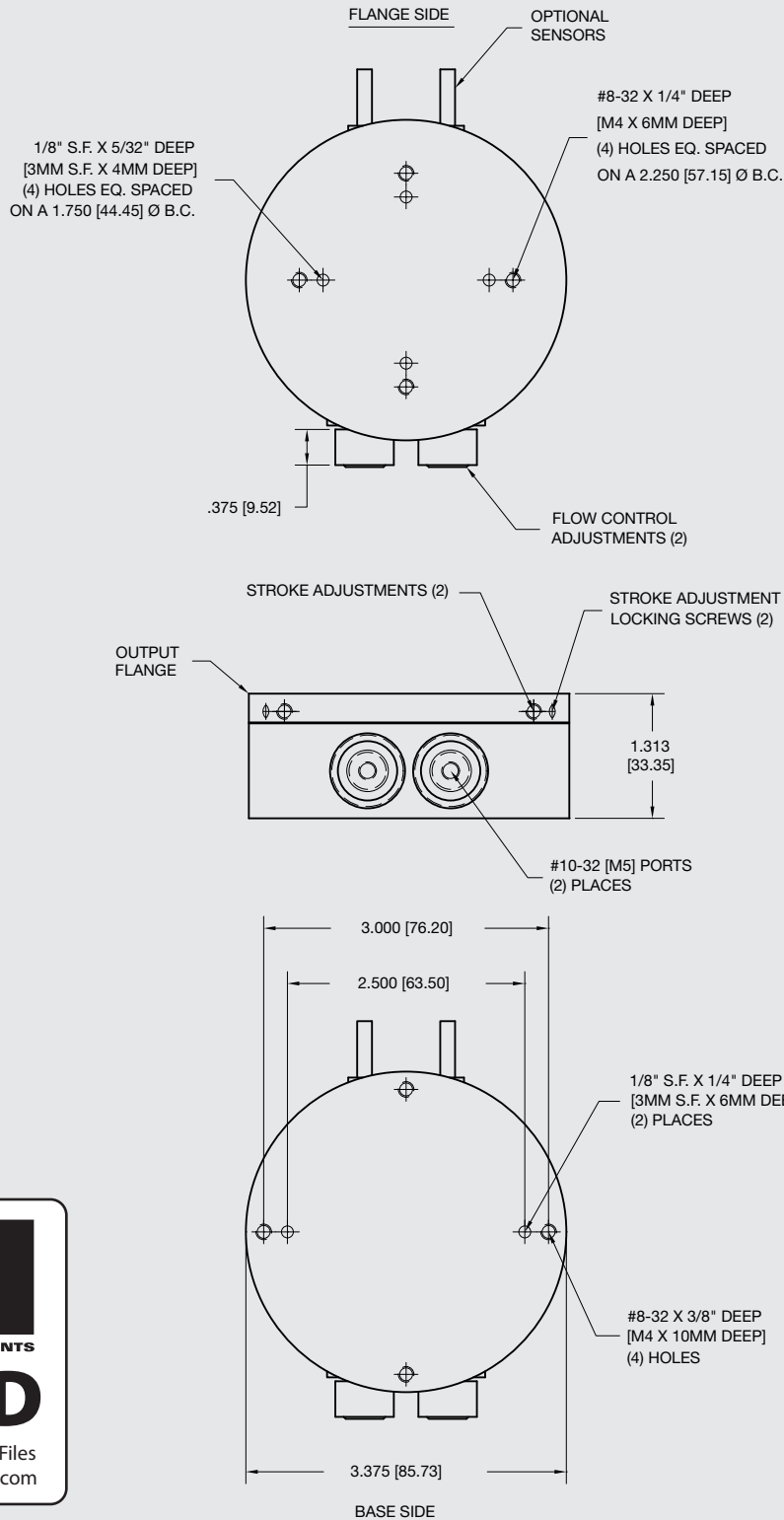

Unless noted, all tolerances are as indicated here:



All Dowel Holes are SF (Slip Fit) Locational Tolerance $\pm .0005$ " [0.13mm]



Metric Threads Course Pitch

Imperial: 0.00 = ± 0.1
0.000 = ± 0.005
0.0000 = ± 0.0005

Metric: [0.] = ± 0.25
[mm] [0.0] = ± 0.13
[0.00] = ± 0.13

AGR-2P/AGR-2H Rotary Actuator

Mid Position and External Shock Options

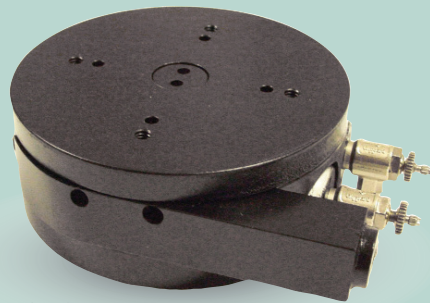

AGR-2P

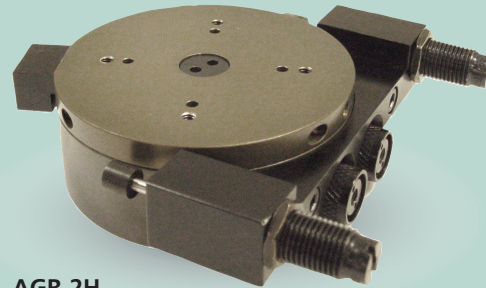

AGR-2H

SPECIFICATIONS

Design: Rack and Pinion with Flange Hard Stop

Rotation Range: 0°-180° (Adj. +/- 5°)

Payload: 3 lbs central to axis of rotation [1.4 Kg]

Torque:
@80 psi [5.5 BAR] 17 in/lb [1.9 Nm]

Bearing Load:
Dynamic 198 lbs [880 N]
Static 385 lbs [1620 N]

Rotation Time:
No load .2 Sec [.2 sec]

Pressure Range:
Low/High 30-120 PSI [2-8 BAR]

Temperature Range:
Low/High -20°/180°F [-28°/80°C]

Backlash: Zero

Accuracy: .001 concentric and perpendicular to axis of rotation

Material: High Strength, Hard Coated Aluminum Alloys, Steel

Weight: 1.2 lb [.5 kg]

Piston Diameter: (2x) .75 in [1.9 mm]

January 2009 - PATENTED Made in the USA

THREE POSITION STOP

The three-position stop option is available on the AGR-2. It provides an extra stop at 90 degrees between 0 and 180 degree of rotation. The mid stop cylinder is single acting, so a three way / two-position valve is required to actuate it. The rotary will need its own four way / two-position valve.

SEQUENCING

The rotary actuator ports A and B will only control clockwise and counter clockwise rotation. Port C will control the mid position stop. With no air pressure on port C the 180 degree rotary will stop at 90 degree. With air pressure on port C the rotary will travel the full 180 degree.

CAUTION: Rotary actuator must be in the full clockwise position before removing pressure from port C.

EXTERNAL SHOCK OPTION

Double the payload of the AGR-2 with the external shock option. Two shocks decelerate the load and allow higher payloads and fast cycle times.

HOW TO ORDER

When ordering, please specify:
Design/Model Number and Options.

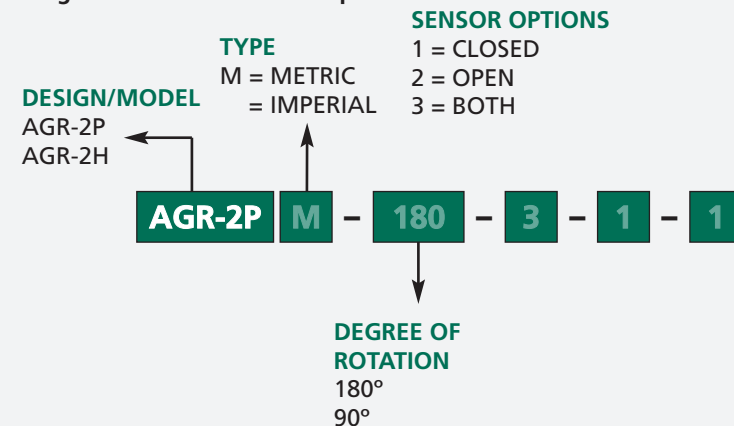

* NOTE: Proximity 4mm dia., 5-24 VDC, 22 mA and comes with 2 meter cable.

Sensor Part # SPC05, SPQ05, SNC05, SNQ05

AGR-2P/AGR-2H Rotary Actuator

Mid Position and External Shock Options

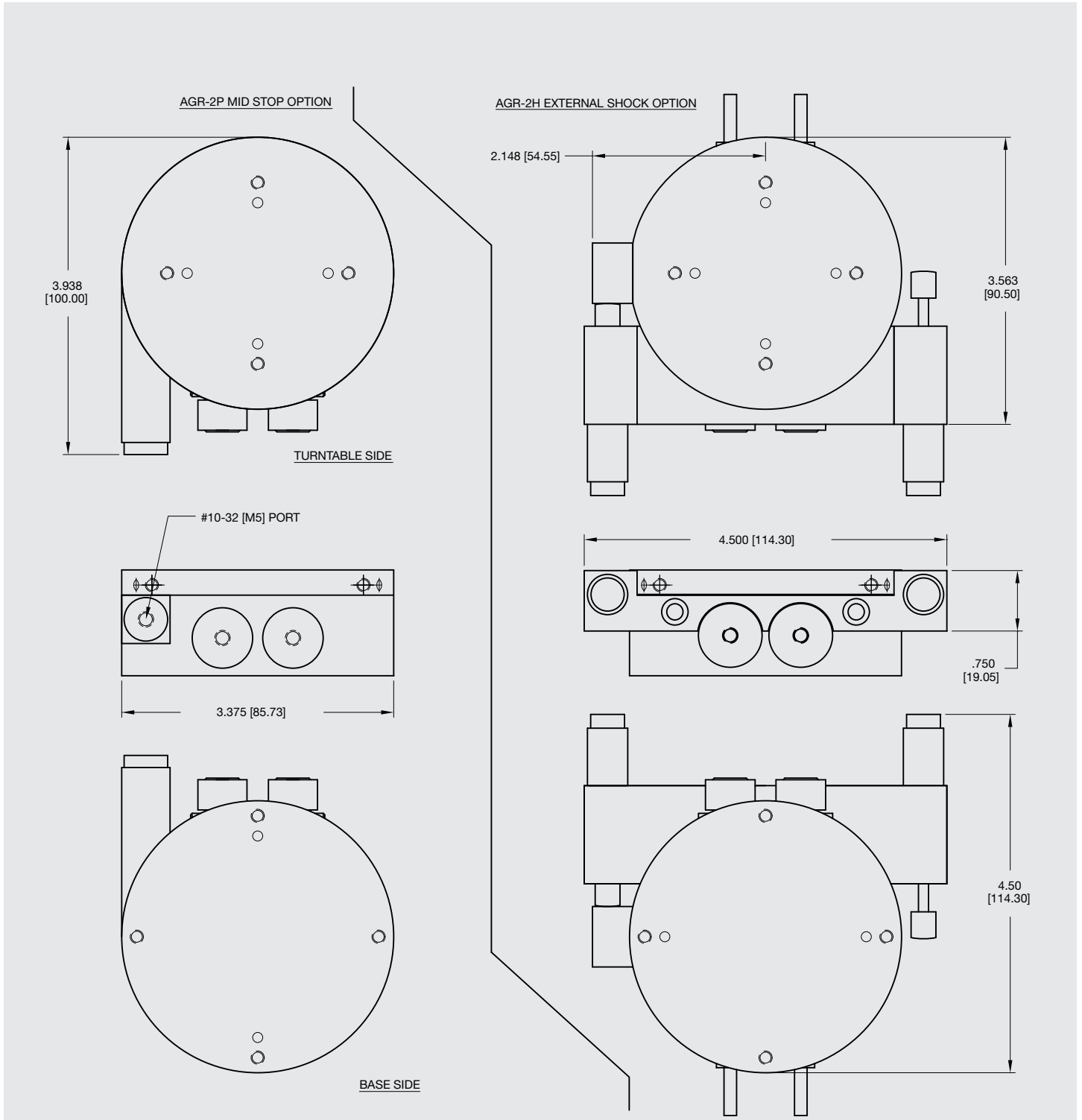

Unless noted, all tolerances are as indicated here:



All Dowel Holes are SF (Slip Fit) Locational Tolerance $\pm .0005"$ [0.13mm]



Metric Threads Course Pitch

Imperial: 0.00 = ± 0.1
0.000 = ± 0.005
0.0000 = ± 0.0005

Metric: [0.] = ± 0.25
[0.0] = ± 0.13
[0.00] = ± 0.13

AGR-3 Rotary Actuator

Low Profile, Zero Backlash, Optional Rotary Manifold

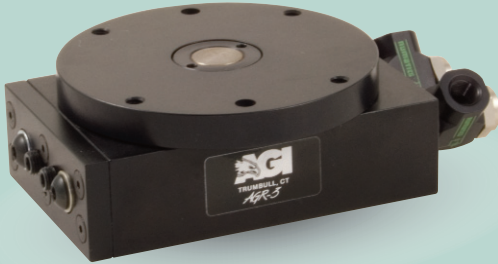

FEATURES AND BENEFITS

- Built in adjustable hardstops on output flange stops against a dowel pin imbedded in the body to prevent pinion breakage, and give accurate specific rotation requirements.
- Two large bearings, one on either side of the pinion, provides for steady output flange with high loading capacity.
- Ultra high torque to weight ratio for faster cycle times.
- Compact body design to fit into tight space applications.
- Units are permanently lubricated for non-lube air operation, allowing compliance with OSHA regulations.
- All rotary units have zero backlash at either end of rotation, this keeps the output flange against the hard stop.
- Built in adjustable flow controls allow for maximum cycle times and smooth deceleration.
- Proximity switches are available to monitor end of rotation.
- The AGR unit is fully repairable for cost savings and minimum down time.

SPECIFICATIONS

Design: Rack and Pinion with Flange Hard Stop

Rotation Range:	0°-180° (Adj. +/- 5°)	
Payload:	8 lbs central to axis of rotation [3.6 Kg]	
Torque: @80 psi [5.5 BAR]	50 in/lb	[5.6 Nm]
Bearing Load:		
Dynamic	360 lbs	[1600 N]
Static	940 lbs	[4180 N]
Rotation Time:	No load	.35 second
Pressure Range: Low/High	30-120 PSI [2-8 BAR]	
Temperature Range: Low/High	-20°/180°F [-28°/80°C]	
Backlash:	Zero	
Accuracy:	.001 concentric and perpendicular to axis of rotation	

Material: High Strength, Hard Coated Aluminum Alloys, Steel

Weight:	3.0 lb	[1.4 kg]
Piston Diameter: (2x)	1.0 in	[25.4 mm]

January 2009 - PATENTED Made in the USA

LOADING INFORMATION

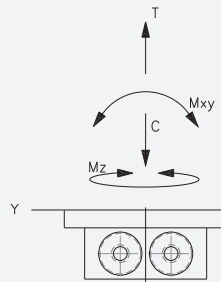

	Static	Dynamic
Max Tensile T	100 lbs [444 N]	20 lbs [89 N]
Max Compressive C	500 lbs [2224 N]	100 lbs [444 N]
Max Moment M _x	300 in/lb [33.8 Nm]	75 in/lb [8.5 Nm]
Max Moment M _y	300 in/lb [33.8 Nm]	75 in/lb [8.5 Nm]

WARNING! Do not exceed tooling jaw length.

HOW TO ORDER

When ordering, please specify:
Design/Model Number and Options.

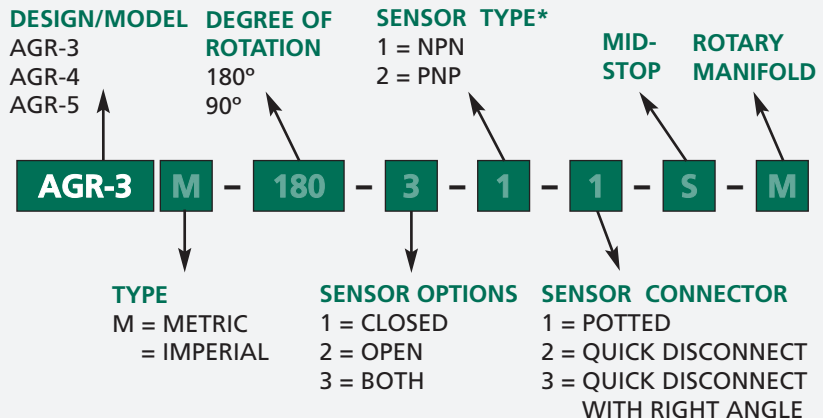

* NOTE: Proximity 4mm dia., 5-24 VDC, 22 mA and comes with 2 meter cable.

Sensor Part # SPC05, SPQ05, SNC05, SNQ05

AGR-3 Rotary Actuator

Low Profile, Zero Backlash, Optional Rotary Manifold

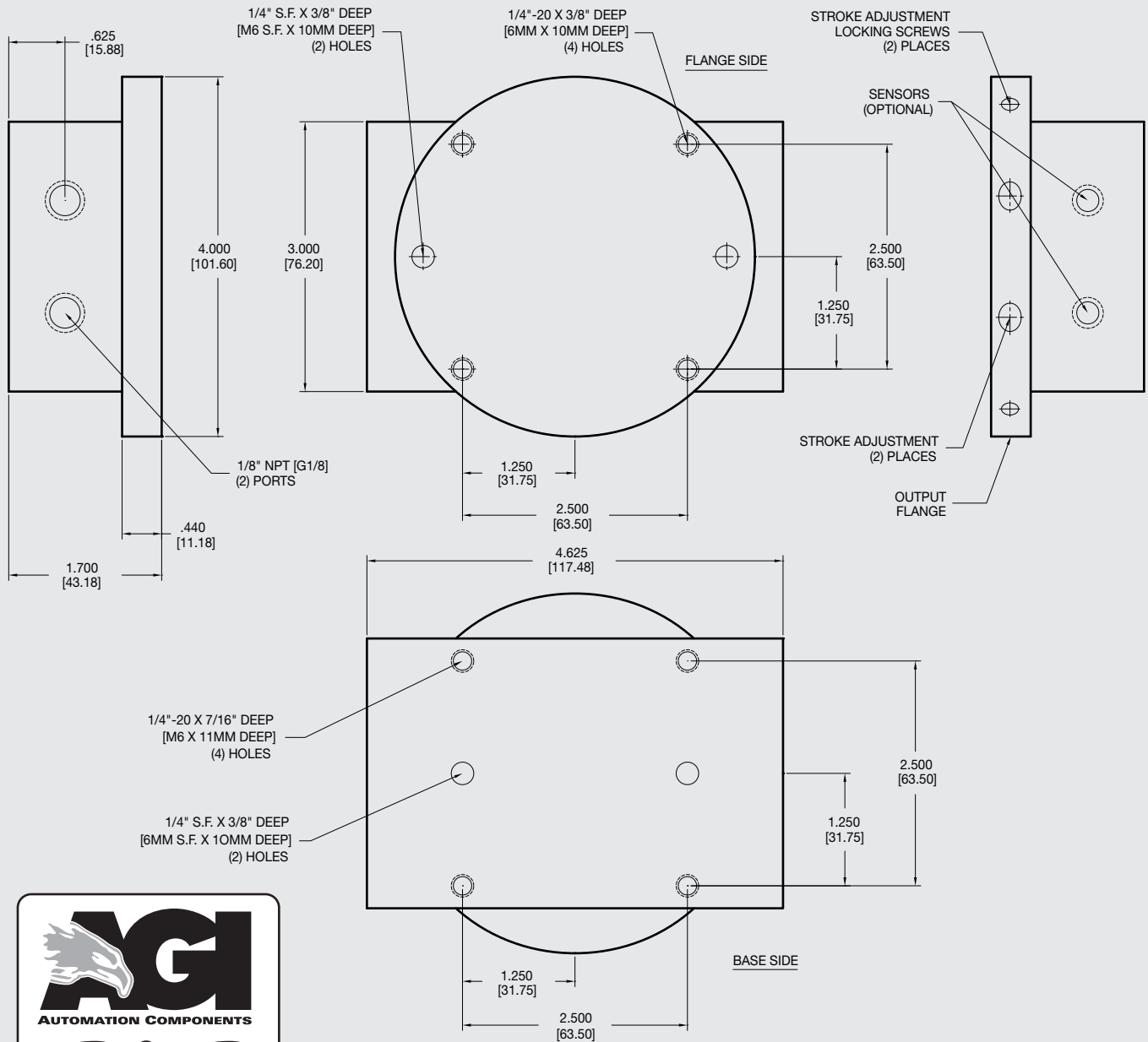

Unless noted, all tolerances are as indicated here:



All Dowel Holes are SF (Slip Fit) Locational Tolerance $\pm .0005"$ [0.013mm]



Metric Threads Course Pitch

Imperial:
Inch

0.00 = $\pm .01$
0.000 = $\pm .005$
0.0000 = $\pm .0005$

Metric:
[mm]
[0.] = $\pm .25$
[0.0] = $\pm .13$
[0.00] = $\pm .013$

AGR-3 Rotary Actuator

Low Profile, Zero Backlash, Optional Rotary Manifold

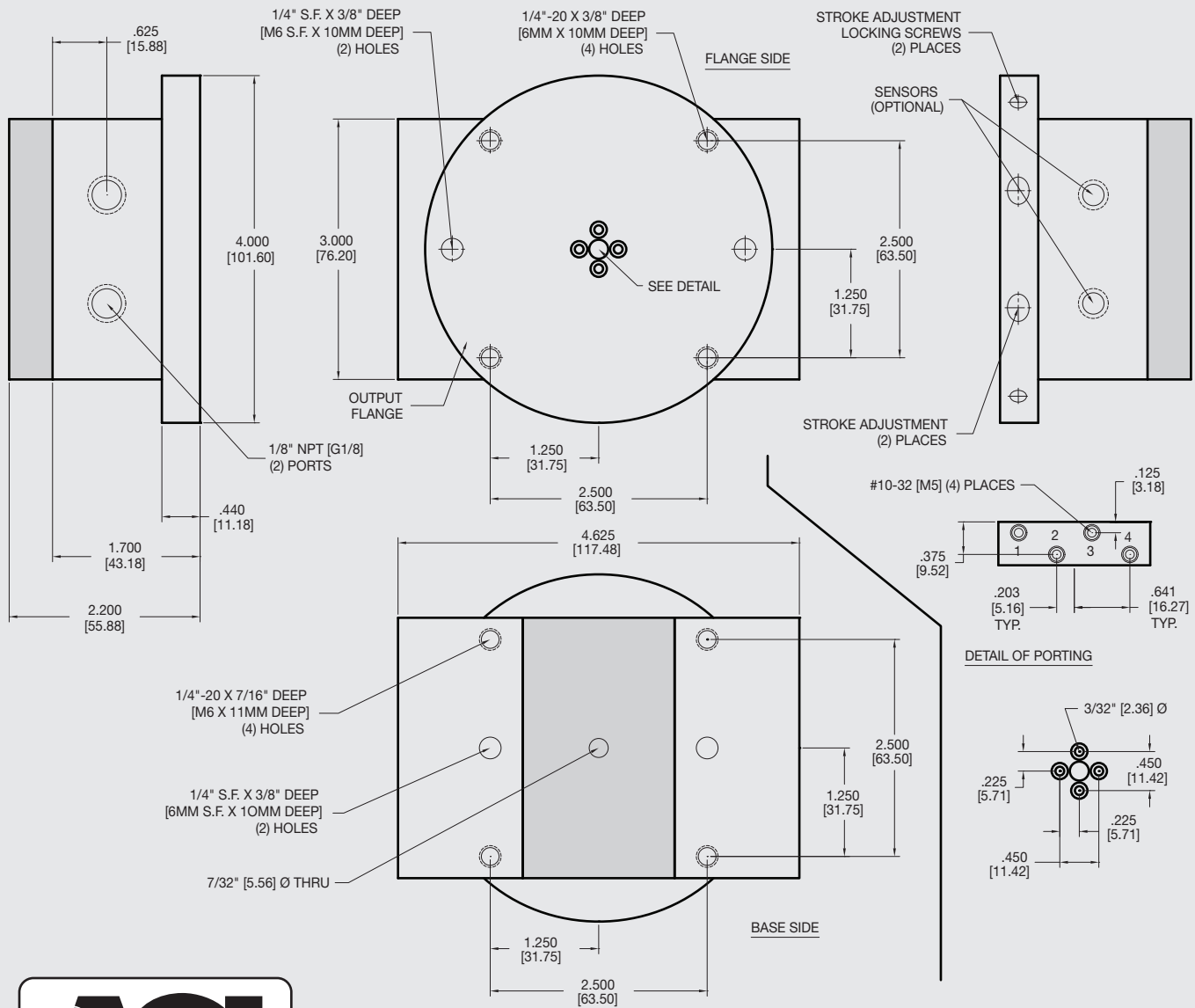

AGI
AUTOMATION COMPONENTS
2D & 3D
Download 2D & 3D CAD Files
@ www.AGI-Automation.com

-M option
Rotary Manifold shown shaded

Unless noted, all tolerances are as indicated here:



All Dowel Holes are SF (Slip Fit) Locational Tolerance ± .0005" [.013mm]



Metric Threads Course Pitch

Imperial: 0.00 = ±.01
Inch 0.000 = ±.005
0.0000 = ±.0005

Metric: [0.] = ±.25
[mm] [0.0] = ±.13
[0.00] = ±.013

AGR-3 Rotary Actuator

Low Profile, Zero Backlash, Optional Rotary Manifold

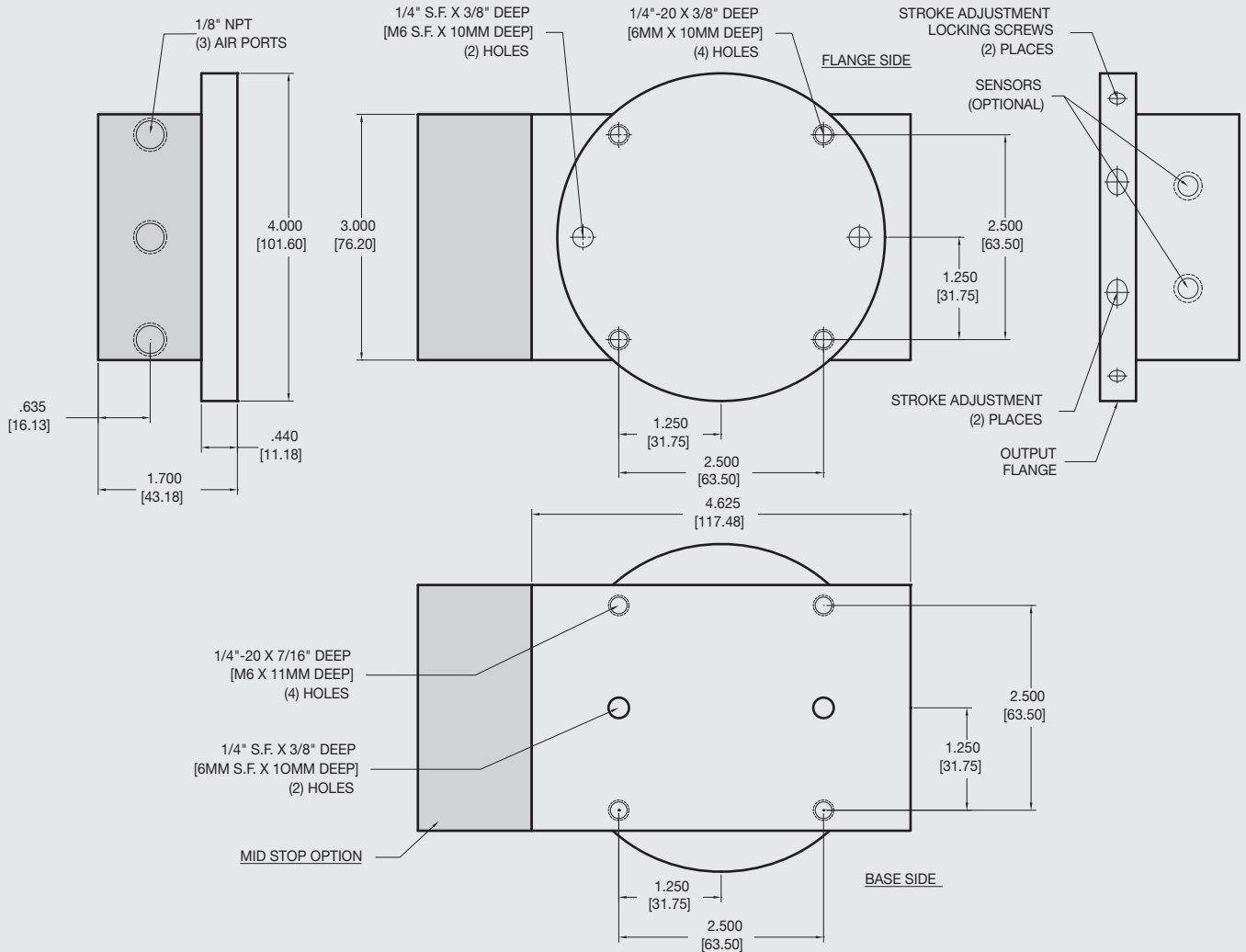

-S option
Mid-Stop shown shaded

Unless noted, all tolerances are as indicated here:



All Dowel Holes are SF (Slip Fit) Locational Tolerance $\pm .0005"$ [.013mm]



Metric Threads Course Pitch

Imperial:
Inch 0.00 = $\pm .01$
0.000 = $\pm .005$
0.0000 = $\pm .0005$

Metric: [0.] = $\pm .25$
[mm] [0.0] = $\pm .13$
[0.00] = $\pm .013$



AGR-4 Rotary Actuator

Low Profile, Zero Backlash, Optional Rotary Manifold

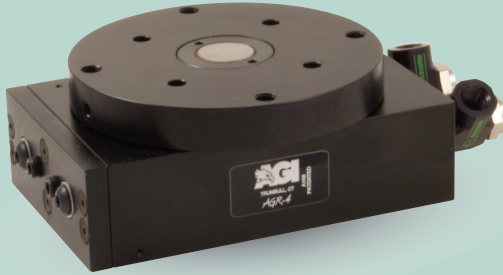

FEATURES AND BENEFITS

- Built in adjustable hardstops on output flange stops against a dowel pin imbedded in the body to prevent pinion breakage, and give accurate specific rotation requirements.
- Two large bearings, one on either side of the pinion, provides for steady output flange with high loading capacity.
- Ultra high torque to weight ratio for faster cycle times.
- Compact body design to fit into tight space applications.
- Units are permanently lubricated for non-lube air operation, allowing compliance with OSHA regulations.
- All rotary units have zero backlash at either end of rotation, this keeps the output flange against the hard stop.
- Built in adjustable flow controls allow for maximum cycle times and smooth deceleration.
- Proximity switches are available to monitor end of rotation.
- The AGR unit is fully repairable for cost savings and minimum down time.

SPECIFICATIONS

Design: Rack and Pinion with Flange Hard Stop

Rotation Range: 0°-180° (Adj. +/- 5°)

Payload: 15 lbs central to axis of rotation [6.8 Kg]

Torque:
@80 psi [5.5 BAR] 100 in/lb [11.3 Nm]

Bearing Load:
Dynamic 1390 lbs [6180 N]
Static 2150 lbs [9560 N]

Rotation Time: No load .40 second

Pressure Range:
Low/High 30-120 PSI [2-8 BAR]

Temperature Range:
Low/High -20°/180°F [-28°/80°C]

Backlash: Zero

Accuracy: .001 concentric and perpendicular to axis of rotation

Material: High Strength, Hard Coated Aluminum Alloys, Steel

Weight: 5.0 lb [2.3 kg]

Piston Diameter: (2x) 1.25 in [32 mm]

January 2009 - PATENTED Made in the USA

LOADING INFORMATION

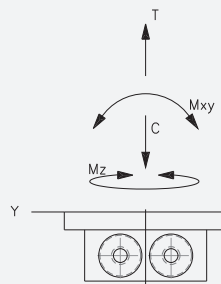

	Static	Dynamic
Max Tensile T	200 lbs [889 N]	40 lbs [177 N]
Max Compressive C	1000 lbs [4448 N]	200 lbs [899 N]
Max Moment M_x	500 in/lb [56.5 Nm]	100 in/lb [11.3 Nm]
Max Moment M_y	500 in/lb [56.5 Nm]	100 in/lb [11.3 Nm]

WARNING! Do not exceed tooling jaw length.

HOW TO ORDER

When ordering, please specify:
Design/Model Number and Options.

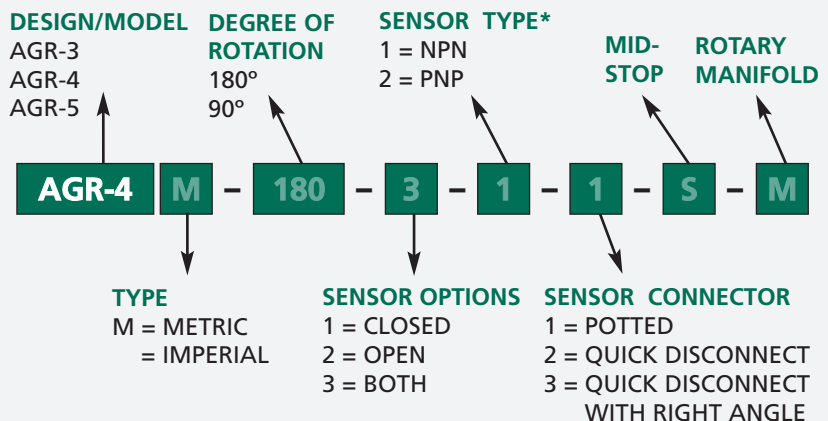

* NOTE: Proximity 4mm dia., 5-24 VDC, 22 mA and comes with 2 meter cable.

Sensor Part # SPC05, SPQ05, SNC05, SNQ05

AGR-4 Rotary Actuator

Low Profile, Zero Backlash, Optional Rotary Manifold

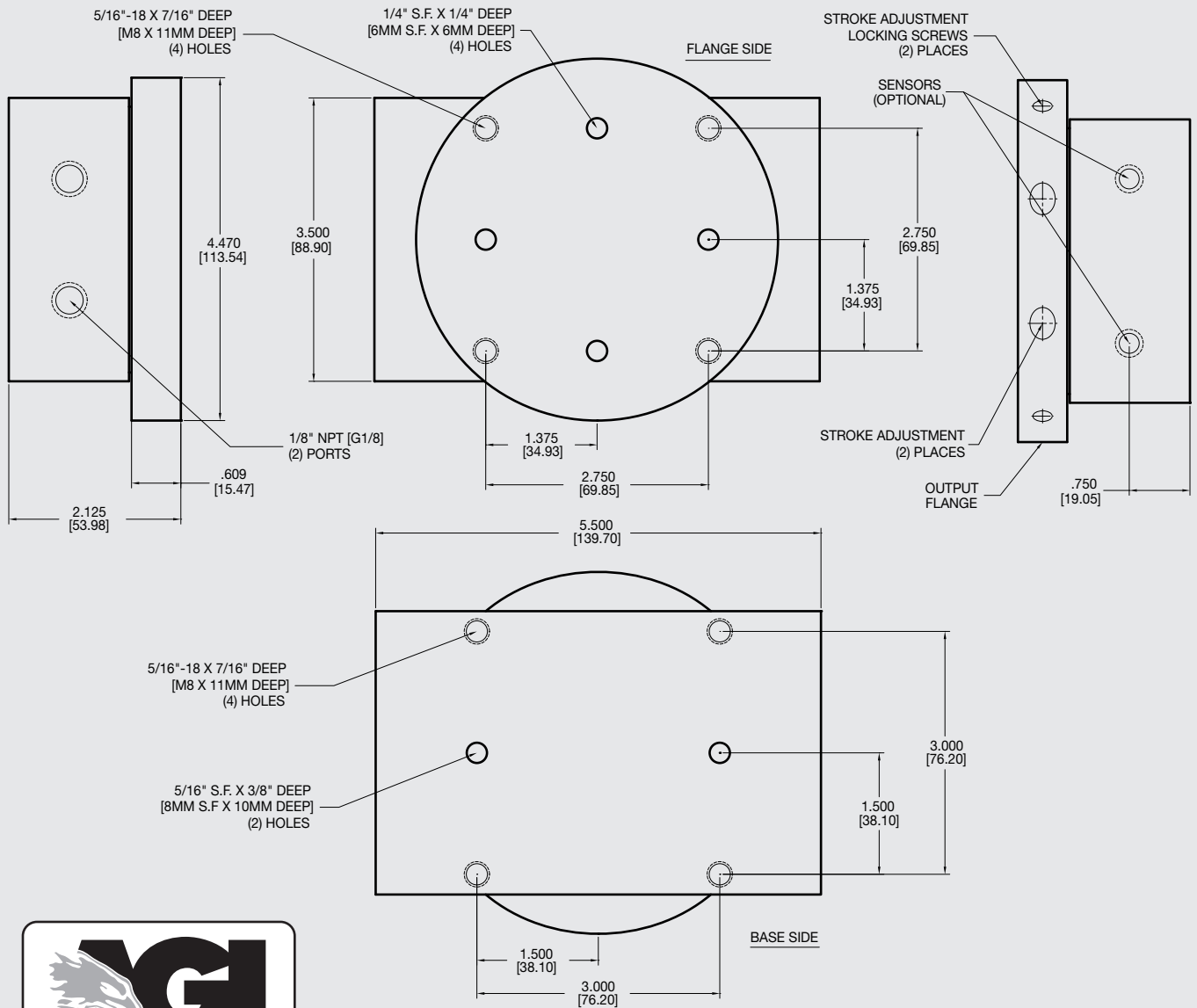

Unless noted, all tolerances are as indicated here:



All Dowel Holes are SF (Slip Fit) Locational Tolerance $\pm .0005"$ [.013mm]



Metric Threads Course Pitch

Imperial:
Inch 0.00 = $\pm .01$
0.000 = $\pm .005$
0.0000 = $\pm .0005$

Metric: [0.] = $\pm .25$
[0.0] = $\pm .13$
[0.00] = $\pm .013$

AGR-4 Rotary Actuator

Low Profile, Zero Backlash, Optional Rotary Manifold

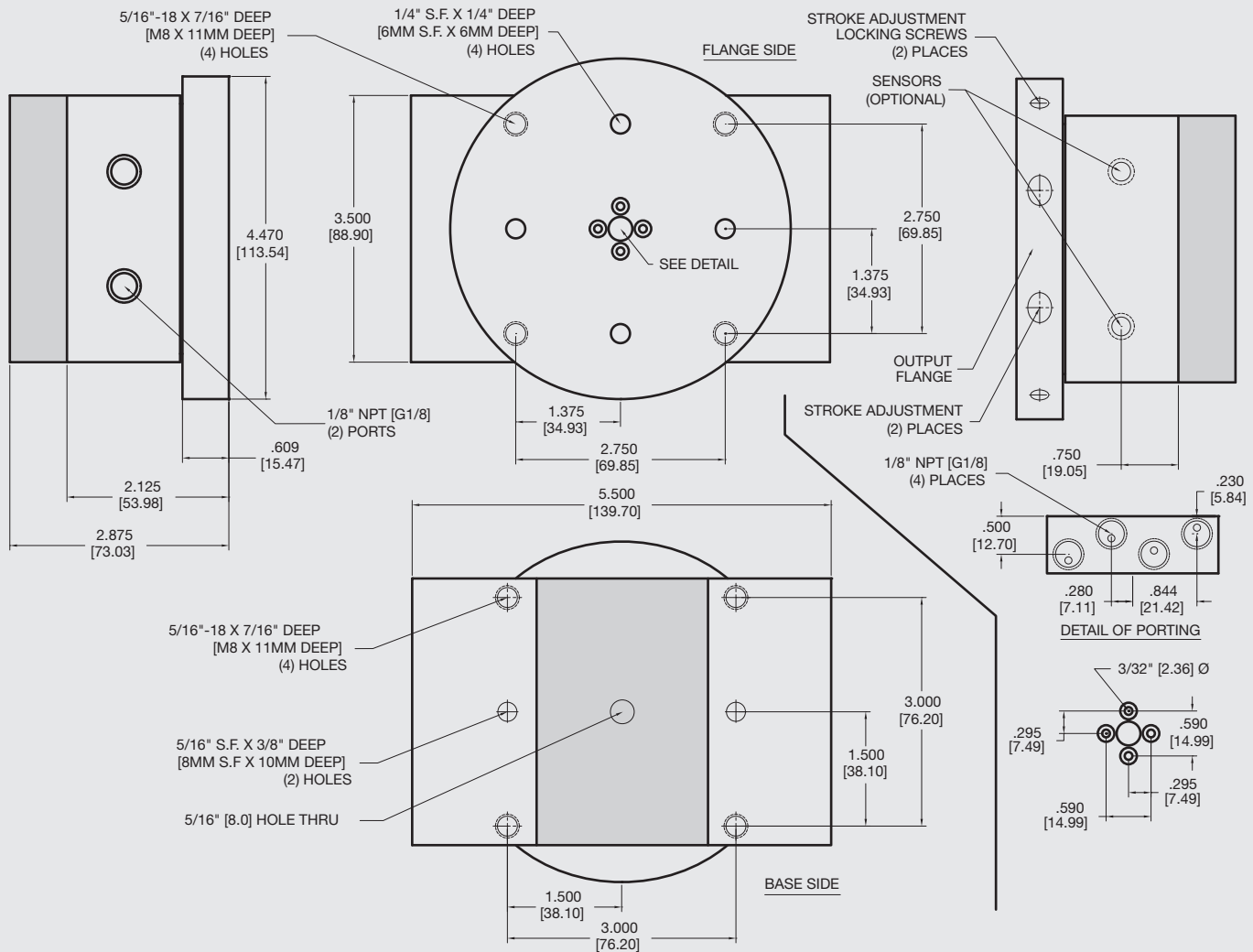

-M option
Rotary Manifold shown shaded

Unless noted, all tolerances are as indicated here:



All Dowel Holes are SF (Slip Fit) Locational Tolerance ± .0005" [0.013mm]



Metric Threads Course Pitch

Imperial: 0.00 = ±.01
Inch 0.000 = ±.005
0.0000 = ±.0005

Metric: [0.] = ±.25
[mm] [0.0] = ±.13
[0.00] = ±.013

AGR-4 Rotary Actuator

Low Profile, Zero Backlash, Optional Rotary Manifold

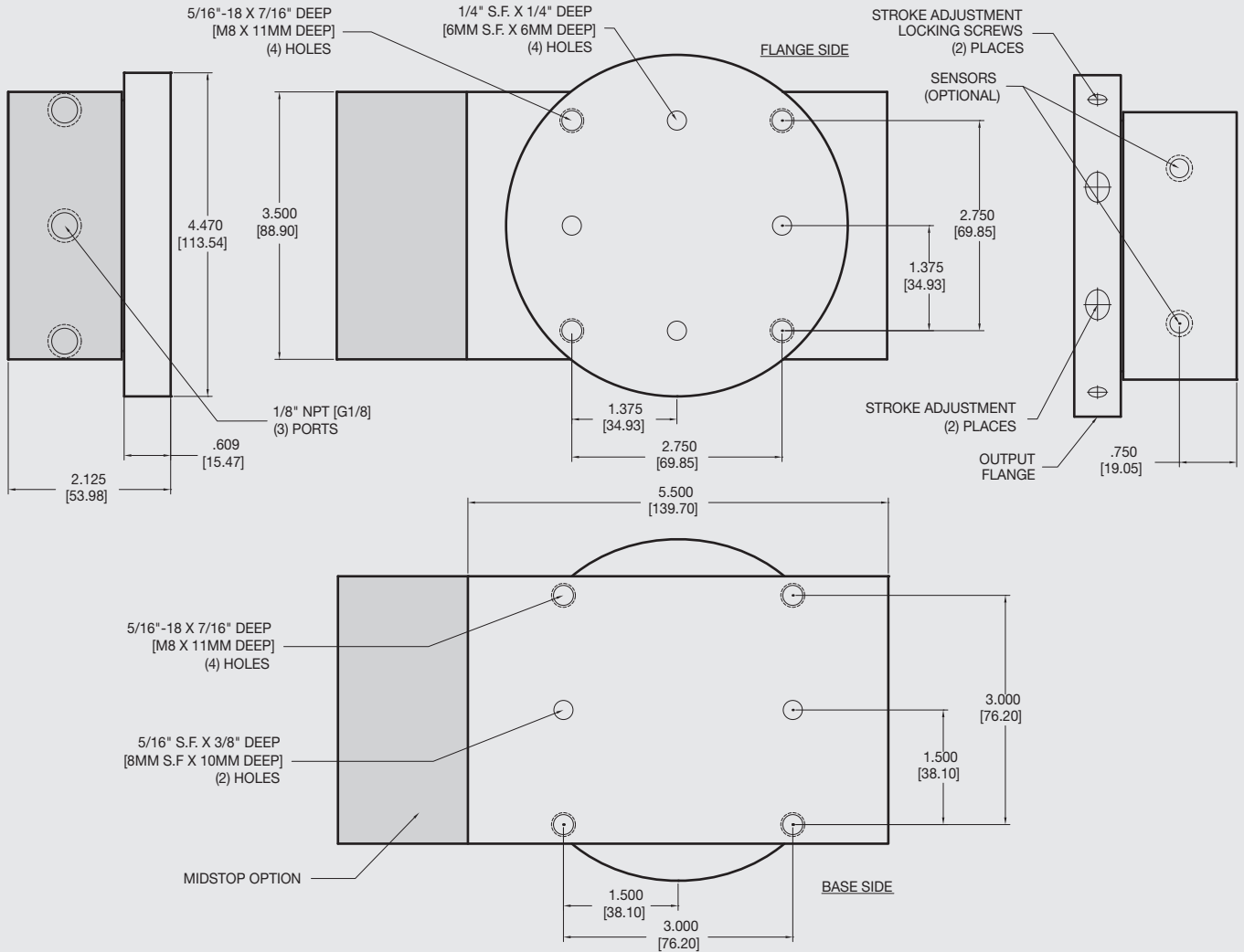

-S option
Mid-Stop shown shaded

Unless noted, all tolerances are as indicated here:



All Dowel Holes are SF (Slip Fit) Locational Tolerance $\pm .0005"$ [.013mm]



Metric Threads Course Pitch

Imperial:
Inch

0.00 = $\pm .01$
0.000 = $\pm .005$
0.0000 = $\pm .0005$

Metric:
[mm]
[0.] = $\pm .25$
[0.0] = $\pm .13$
[0.00] = $\pm .013$



AGR-5 Rotary Actuator

Low Profile, Zero Backlash

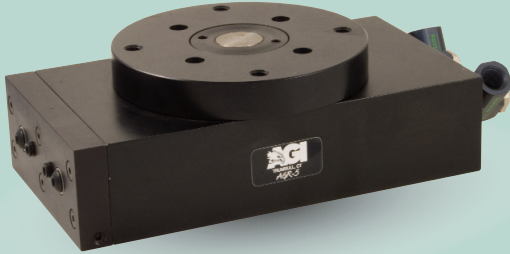

FEATURES AND BENEFITS

- Built in adjustable hardstops on output flange stops against a dowel pin imbedded in the body to prevent pinion breakage, and give accurate specific rotation requirements.
- Two large bearings, one on either side of the pinion, provides for steady output flange with high loading capacity.
- Ultra high torque to weight ratio for faster cycle times.
- Compact body design to fit into tight space applications.
- Units are permanently lubricated for non-lube air operation, allowing compliance with OSHA regulations.
- All rotary units have zero backlash at either end of rotation, this keeps the output flange against the hard stop.
- Built in adjustable flow controls allow for maximum cycle times and smooth deceleration.
- Proximity switches are available to monitor end of rotation.
- The AGR unit is fully repairable for cost savings and minimum down time.

SPECIFICATIONS

Design: Rack and Pinion with Flange Hard Stop

Rotation Range:	0°-180° (Adj. +/- 5°)
Payload:	30 lbs central to axis of rotation [13.6 Kg]
Torque: @80 psi [5.5 BAR]	248 in/lb [28 Nm]
Bearing Load:	
Dynamic	1495 lbs [6650 N]
Static	2260 lbs [10050 N]
Rotation Time:	No load .40 second
Pressure Range:	
Low/High	30-120 PSI [2-8 BAR]
Temperature Range:	
Low/High	-20°/180°F [-28°/80°C]
Backlash:	Zero
Accuracy:	.001 concentric and perpendicular to axis of rotation

Material: High Strength, Hard Coated Aluminum Alloys, Steel

Weight:	8.5 lb [3.9 kg]
Piston Diameter: (2x)	1.625 in [41.3 mm]

January 2009 - PATENTED Made in the USA

LOADING INFORMATION

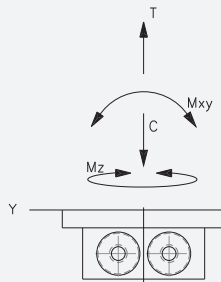

Max Tensile T	Static 800 lbs [3558 N]	Dynamic 160 lbs [711 N]
Max Compressive C	2000 lbs [8800 N]	400 lbs [1780 N]
Max Moment M_x	1000 in/lb [113 Nm]	200 in/lb [22.6 Nm]
Max Moment M_y	1000 in/lb [113 Nm]	200 in/lb [22.6 Nm]

WARNING! Do not exceed tooling jaw length.

HOW TO ORDER

When ordering, please specify:
Design/Model Number and Options.

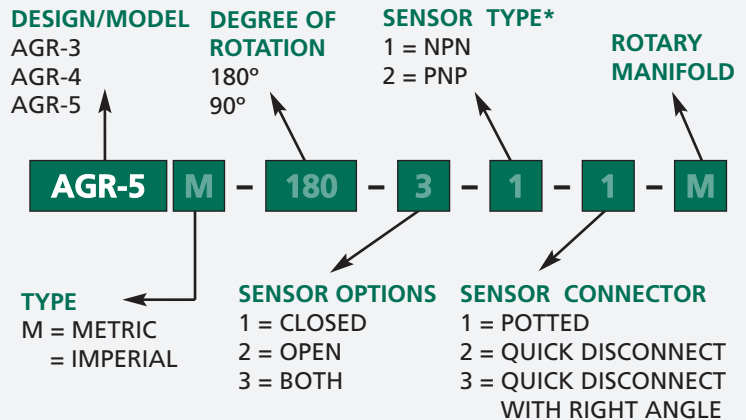

* NOTE: Proximity 4mm dia., 5-24 VDC, 22 mA and comes with 2 meter cable.

Sensor Part # SPC05, SPQ05, SNC05, SNQ05

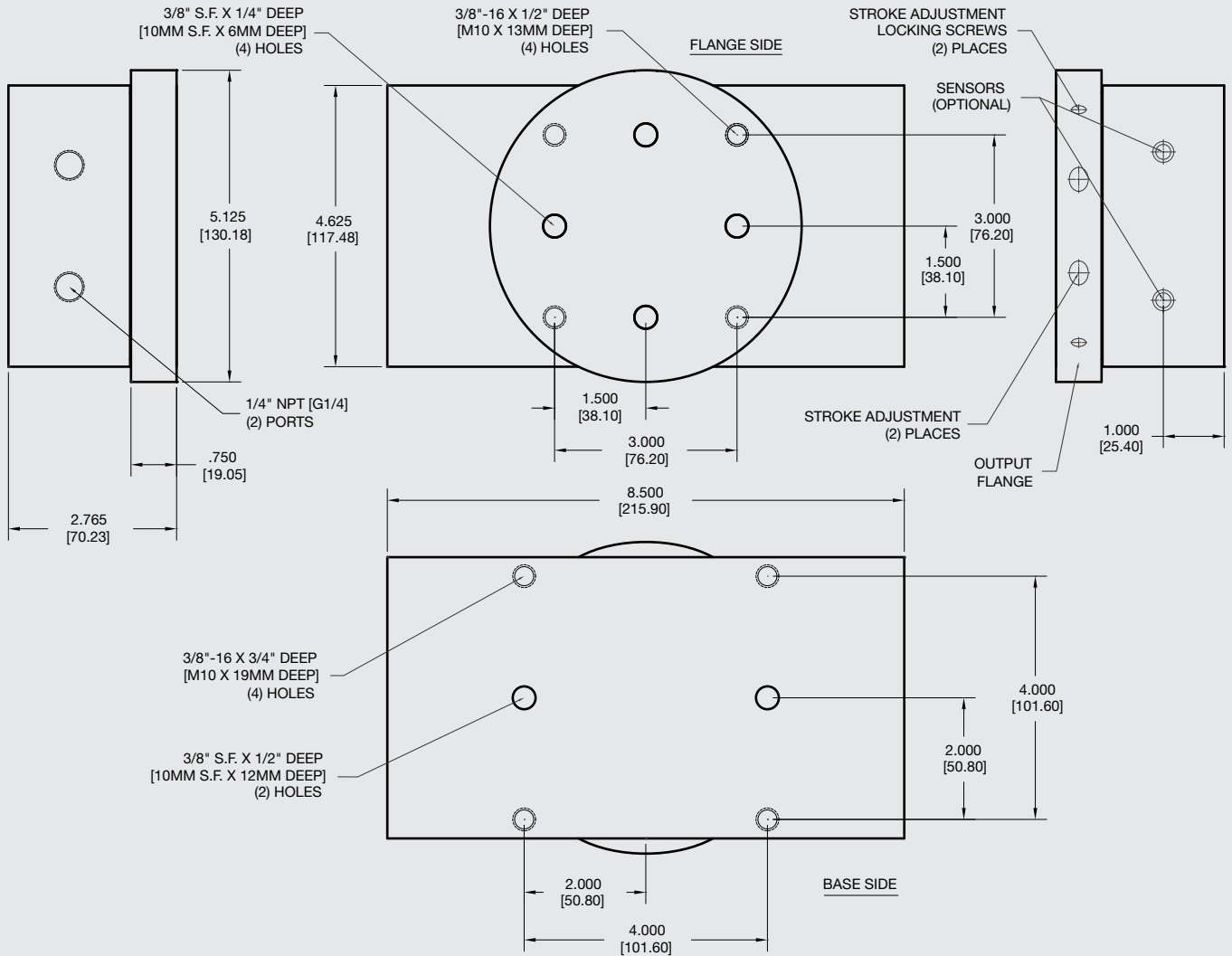

Unless noted, all tolerances are as indicated here:



All Dowel Holes are SF (Slip Fit) Locational Tolerance $\pm .0005"$ [.013mm]



Metric Threads Course Pitch

Imperial: 0.00 = $\pm .01$
0.000 = $\pm .005$
0.0000 = $\pm .0005$

Metric: [0.] = $\pm .25$
[mm] [0.0] = $\pm .13$
[0.00] = $\pm .013$

AGR-5 Rotary Actuator

Low Profile, Zero Backlash, Optional Rotary Manifold

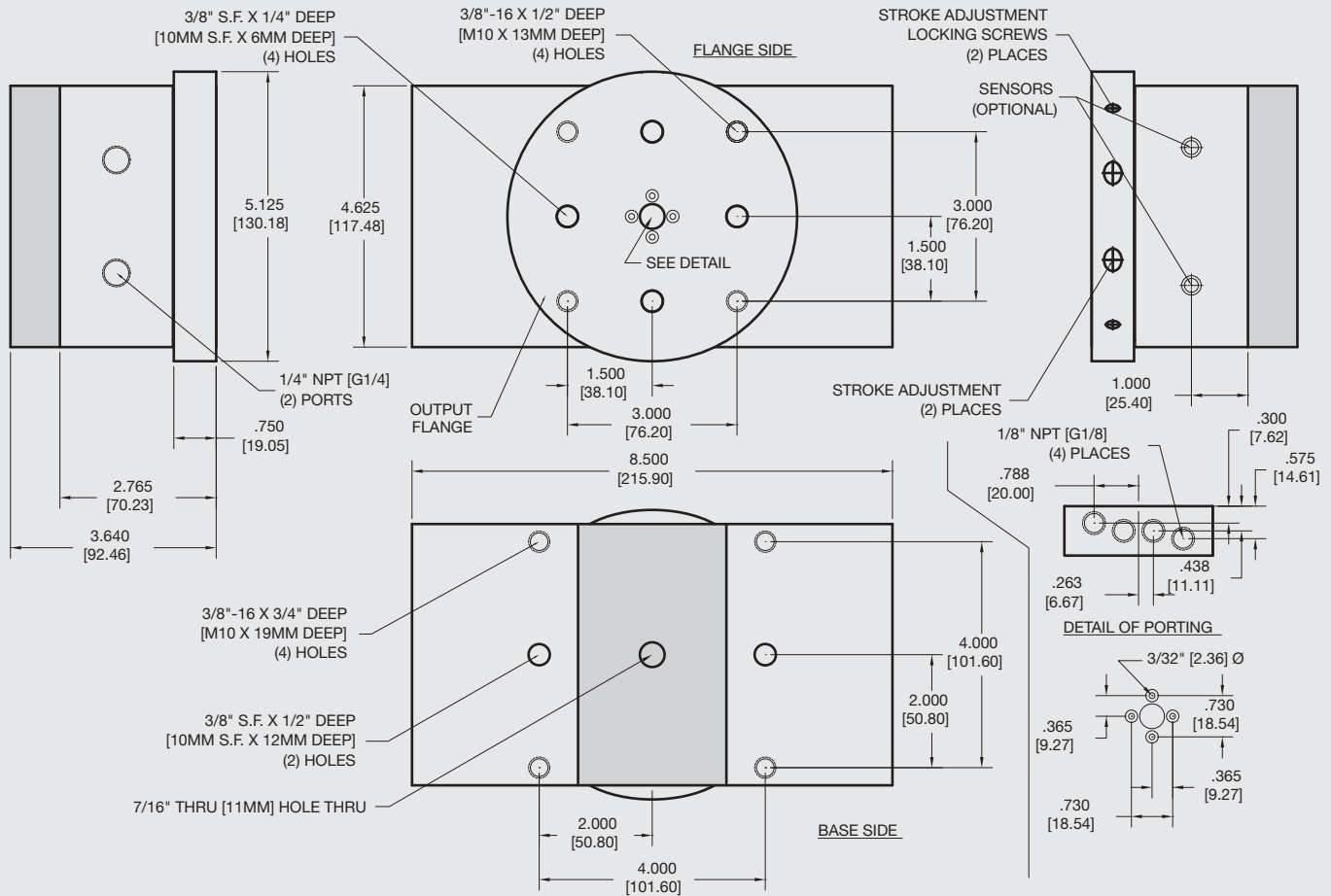

-M option
Rotary Manifold shown shaded

Unless noted, all tolerances are as indicated here:



All Dowel Holes are SF (Slip Fit) Locational Tolerance ± .0005" [.013mm]



Metric Threads Course Pitch

Imperial: 0.00 = ±.01
Inch 0.000 = ±.005
0.0000 = ±.0005

Metric: [0.] = ±.25
[mm] [0.0] = ±.13
[0.00] = ±.013

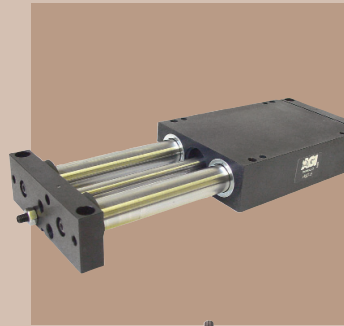

AGMS Series
AGS Series
AGT Series

S
l
i
d
e
s





AGMS-1-1 Mini Powered Slide

Built-In Air Cylinder

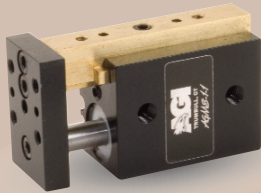

FEATURES AND BENEFITS

- T-Slot bearing support for the carriage and end plate offers superior load bearing performance throughout the stroke.
- Standard built-in stroke adjustment and stroke lock for precise, repetitive operation.
- Compact, lightweight unit with built-in cylinder.
- Piston seals are U-CUP type for long service life.
- Hall Effect sensors are available to monitor stroke position.
- Multiple mounting surfaces on the body and endplate with threaded and counterbored holes for easy mounting choices.

SPECIFICATIONS

Design: Built-in air cylinder
T-slot slide

Stroke: .5 in adj [12.7 mm]

Thrust Force @ 80 PSI [5.5 BAR]

Extended: 15 lbs [66.7 N]
Retract: 13 lbs [57.8 N]

Recommended Speed:

2-12 in/sec
[0.5-.3m/sec]

Pressure Range:

Low/High 20-120 PSI [1.4-8 BAR]

Temperature Range:

Low/High -20°/150°F [-28°/80°C]

Side Play:

± 0.001 [0.03 mm]

Maximum Payload:

3 lbs [1.3 kg]

Material: High Strength, Aluminum Alloys, Bronze

Weight:

2.5 oz [70.1 g]

Piston Diameter:

.50 in [12.7 mm]

January 2009 - PATENTED Made in the USA

MAXIMUM FORCES & MOMENTS

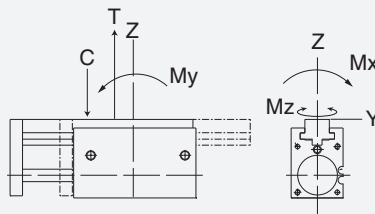

	Static	Dynamic
Max Tensile T	50 lbs [222 N]	20 lbs [89 N]
Max Compressive C	50 lbs [222 N]	20 lbs [89 N]
Max Moment M_x	25 in/lb [2.8 Nm]	15 in/lb [1.7Nm]
Max Moment M_y	30 in/lb [3.4 Nm]	15 in/lb [1.7Nm]
Max Moment M_z	30 in/lb [3.4 Nm]	15 in/lb [1.7Nm]

HOW TO ORDER

When ordering, please specify:
Design/Model Number and Options.

DESIGN/MODEL

- AGMS-1-1
- AGMS-1-2
- AGMS-1-3
- AGMS-1-4

TYPE

M = METRIC
= IMPERIAL

SENSOR TYPE

- 1 = NPN
- 2 = PNP

AGMS-1-1 M - 3 - 1 - 1

SENSOR OPTIONS*

- 1 = LEFT
- 2 = RIGHT
- 3 = BOTH

SENSOR CONNECTOR

- 1 = POTTED
- 2 = QUICK DISCONNECT
- 3 = QUICK DISCONNECT WITH RIGHT ANGLE

* NOTE: Hall Effect sensors – Potted or Quick disconnect.

Sensor Part # SHN01, SHP01, SHNQ3, SHPQ3

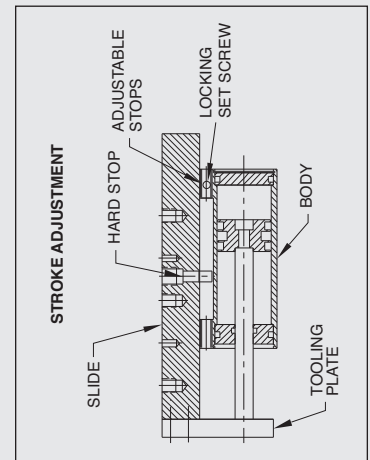
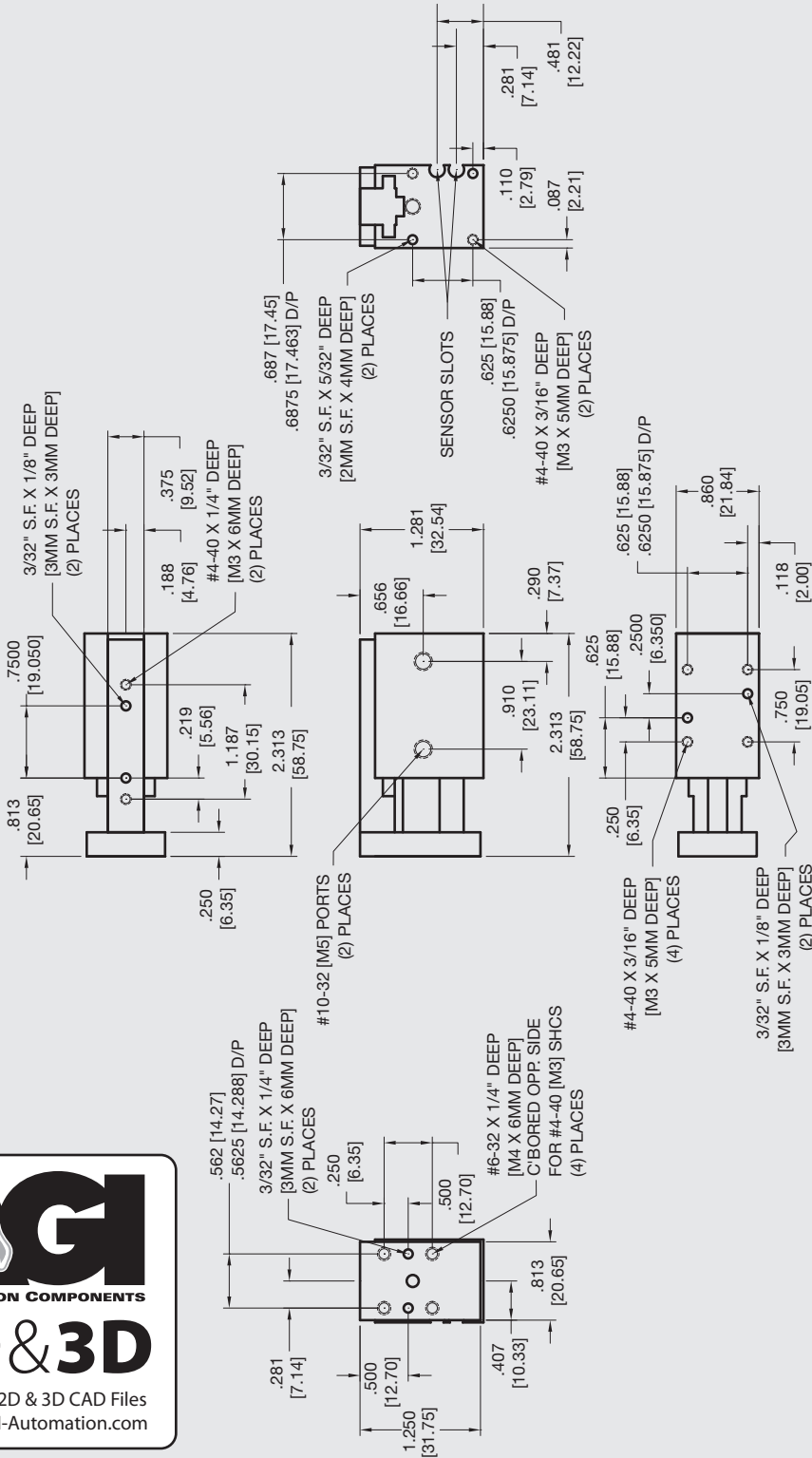

Download 2D & 3D CAD Files
@ www.AGI-Automation.com

Unless noted, all tolerances are as indicated here:



All Dowel Holes are SF (Slip Fit) Locational Tolerance $\pm .0005$ [0.13mm]



Metric Threads Course Pitch

Imperial: 0.00 = $\pm .01$
Inch 0.000 = $\pm .005$
0.0000 = $\pm .0005$

Metric: [0.] = $\pm .25$
[mm] [0.0] = $\pm .13$
[0.00] = $\pm .013$



AGMS-1-2 Mini Powered Slide

Built-In Air Cylinder

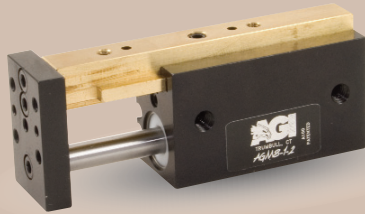

FEATURES AND BENEFITS

- T-Slot bearing support for the carriage and end plate offers superior load bearing performance throughout the stroke.
- Standard built-in stroke adjustment and stroke lock for precise, repetitive operation.
- Compact, lightweight unit with built-in cylinder.
- Piston seals are U-CUP type for long service life.
- Hall Effect sensors are available to monitor stroke position.
- Multiple mounting surfaces on the body and endplate with threaded and counterbored holes for easy mounting choices.

SPECIFICATIONS

Design: Built-in air cylinder
T-slot slide

Stroke: 1 inch [25.4 mm]

Thrust Force @ 80 PSI [5.5 BAR]

Extended: 15 lbs [66.7 N]
Retract: 13 lbs [57.8 N]

Recommended Speed: 2-12 in/sec [0.5-.3m/sec]

Pressure Range: Low/High 20-120 PSI [1.4-8 BAR]

Temperature Range: Low/High -20°/150°F [-28°/80°C]

Side Play: ± 0.001 [.03 mm]

Maximum Payload: 7 lbs [3.2 kg]

Material: High Strength, Aluminum Alloys, Bronze

Weight: 3.2 oz [90 g]

Piston Diameter: .50 in [12.7 mm]

January 2009 - PATENTED Made in the USA

MAXIMUM FORCES & MOMENTS

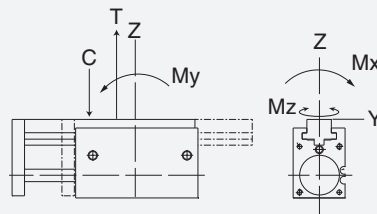

	Static	Dynamic
Max Tensile T	75 lbs [333 N]	32 lbs [142 N]
Max Compressive C	75 lbs [333 N]	32 lbs [142 N]
Max Moment M_x	60 in/lb [6.7 Nm]	30 in/lb [3.4 Nm]
Max Moment M_y	60 in/lb [6.7 Nm]	30 in/lb [3.4 Nm]
Max Moment M_z	60 in/lb [6.7 Nm]	30 in/lb [3.4 Nm]

HOW TO ORDER

When ordering, please specify:
Design/Model Number and Options.

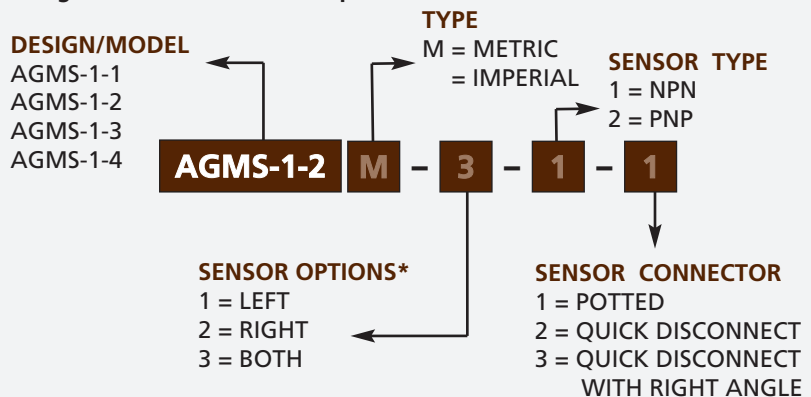

* NOTE: Hall Effect sensors – Potted or Quick disconnect.
Sensor Part # SHN01, SHP01, SHNQ3, SHPQ3

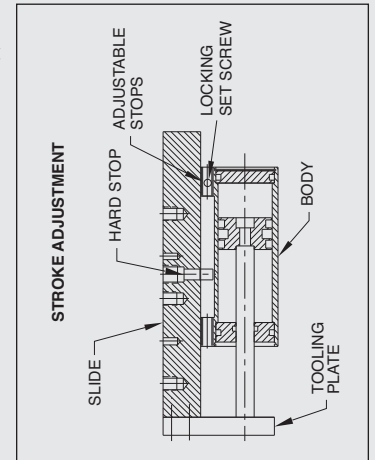
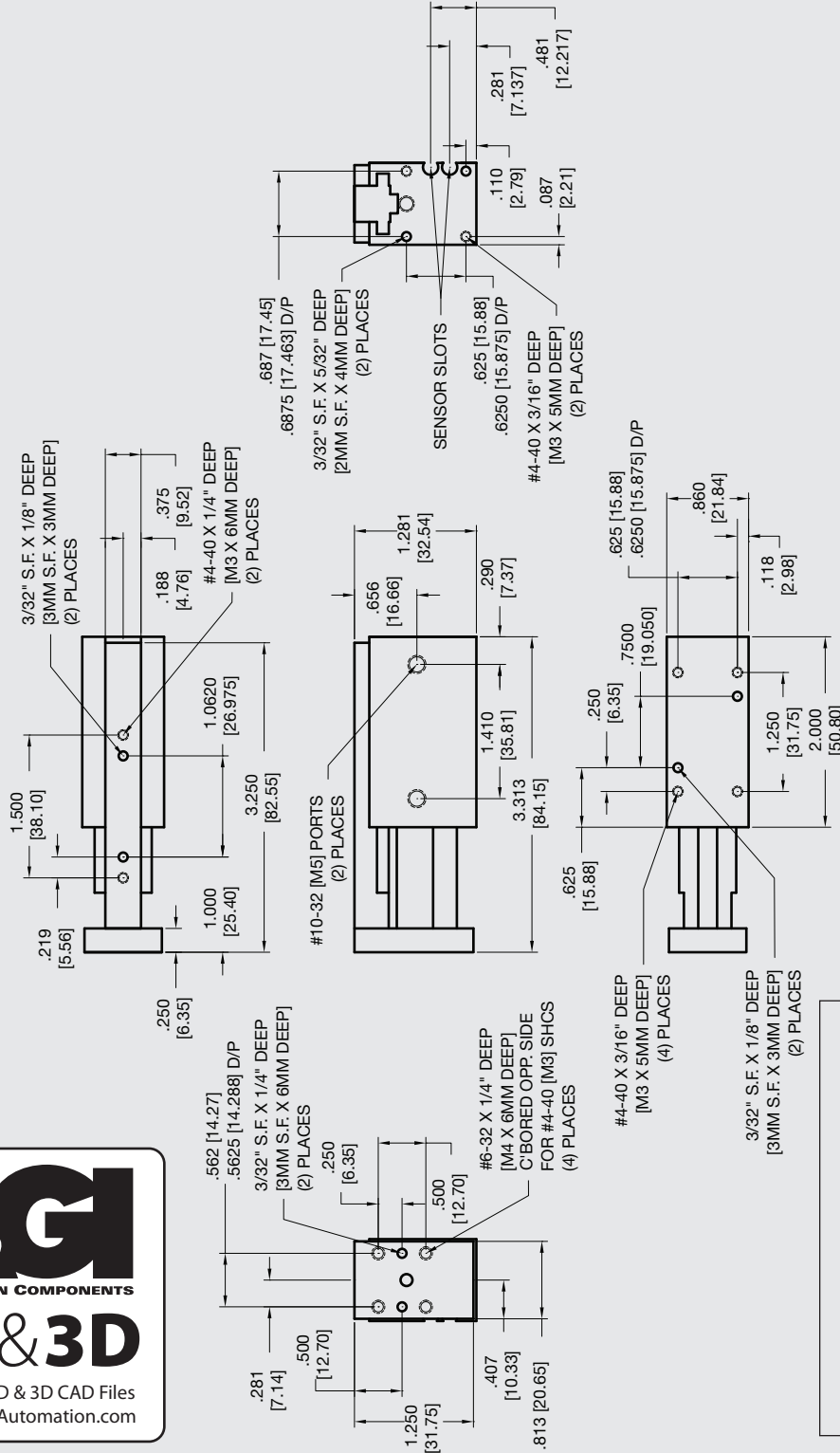

Unless noted, all tolerances are as indicated here:



All Dowel Holes are SF (Slip Fit) Locational Tolerance ± .0005" [0.13mm]



Metric Threads Course Pitch

Imperial:
Inch 0.00 = ±.01
0.000 = ±.005
0.0000 = ±.0005

Metric: [0.] = ±.25
[0.0] = ±.13
[0.00] = ±.013



AGMS-1-3 Mini Powered Slide

Built-In Air Cylinder

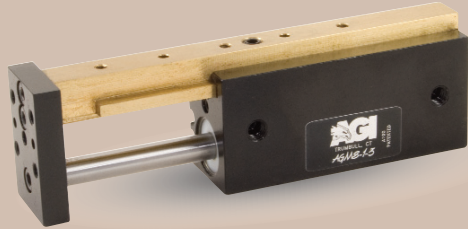

FEATURES AND BENEFITS

- T-Slot bearing support for the carriage and end plate offers superior load bearing performance throughout the stroke.
- Standard built-in stroke adjustment and stroke lock for precise, repetitive operation.
- Compact, lightweight unit with built-in cylinder.
- Piston seals are U-CUP type for long service life.
- Hall Effect sensors are available to monitor stroke position.
- Multiple mounting surfaces on the body and endplate with threaded and counterbored holes for easy mounting choices.

SPECIFICATIONS

Design: Built-in air cylinder
T-slot slide

Stroke: 1.5 in [38.1 mm]

Thrust Force @ 80 PSI [5.5 BAR]

Extended: 15 lbs [66.7 N]
Retract: 13 lbs [57.8 N]

Recommended Speed: 2-12 in/sec
[0.5-.3m/sec]

Pressure Range: Low/High 20-120 PSI [1.4-8 BAR]

Temperature Range: Low/High -20°/150°F [-28°/80°C]

Side Play: ± 0.001 [0.03 mm]

Maximum Payload: 12 lbs [5.4 kg]

Material: High Strength, Aluminum Alloys, Bronze

Weight: 4 oz [113 g]

Piston Diameter: .50 in [12.7 mm]

January 2009 - PATENTED Made in the USA

MAXIMUM FORCES & MOMENTS

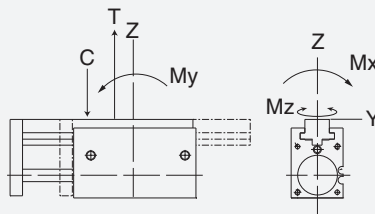

	Static	Dynamic
Max Tensile T	100 lbs [444 N]	42 lbs [186 N]
Max Compressive C	100 lbs [444 N]	42 lbs [186 N]
Max Moment M_x	80 in/lb [9 Nm]	40 in/lb [4.5 Nm]
Max Moment M_y	80 in/lb [9 Nm]	40 in/lb [4.5 Nm]
Max Moment M_z	80 in/lb [9 Nm]	40 in/lb [4.5 Nm]

HOW TO ORDER

When ordering, please specify:
Design/Model Number and Options.

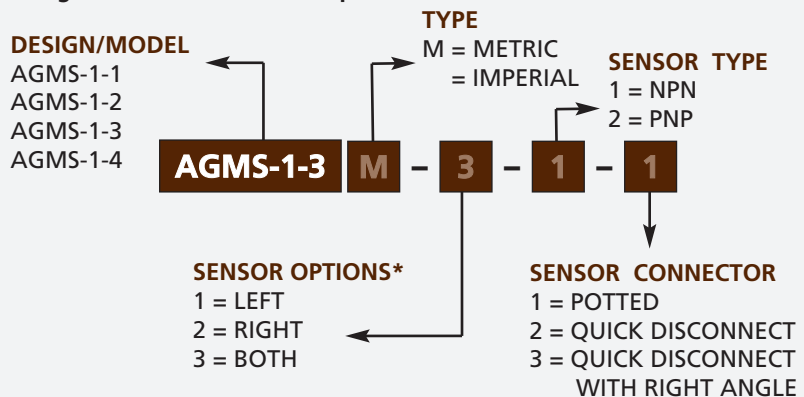

* NOTE: Hall Effect sensors – Potted or Quick disconnect.
Sensor Part # SHN01, SHP01, SHNQ3, SHPQ3

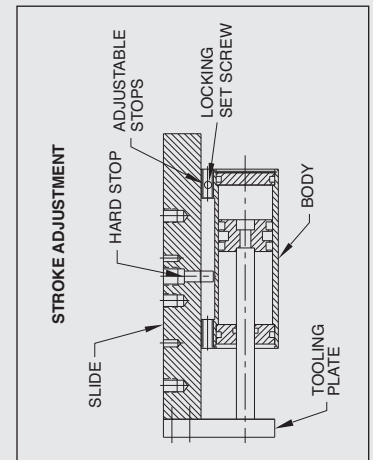
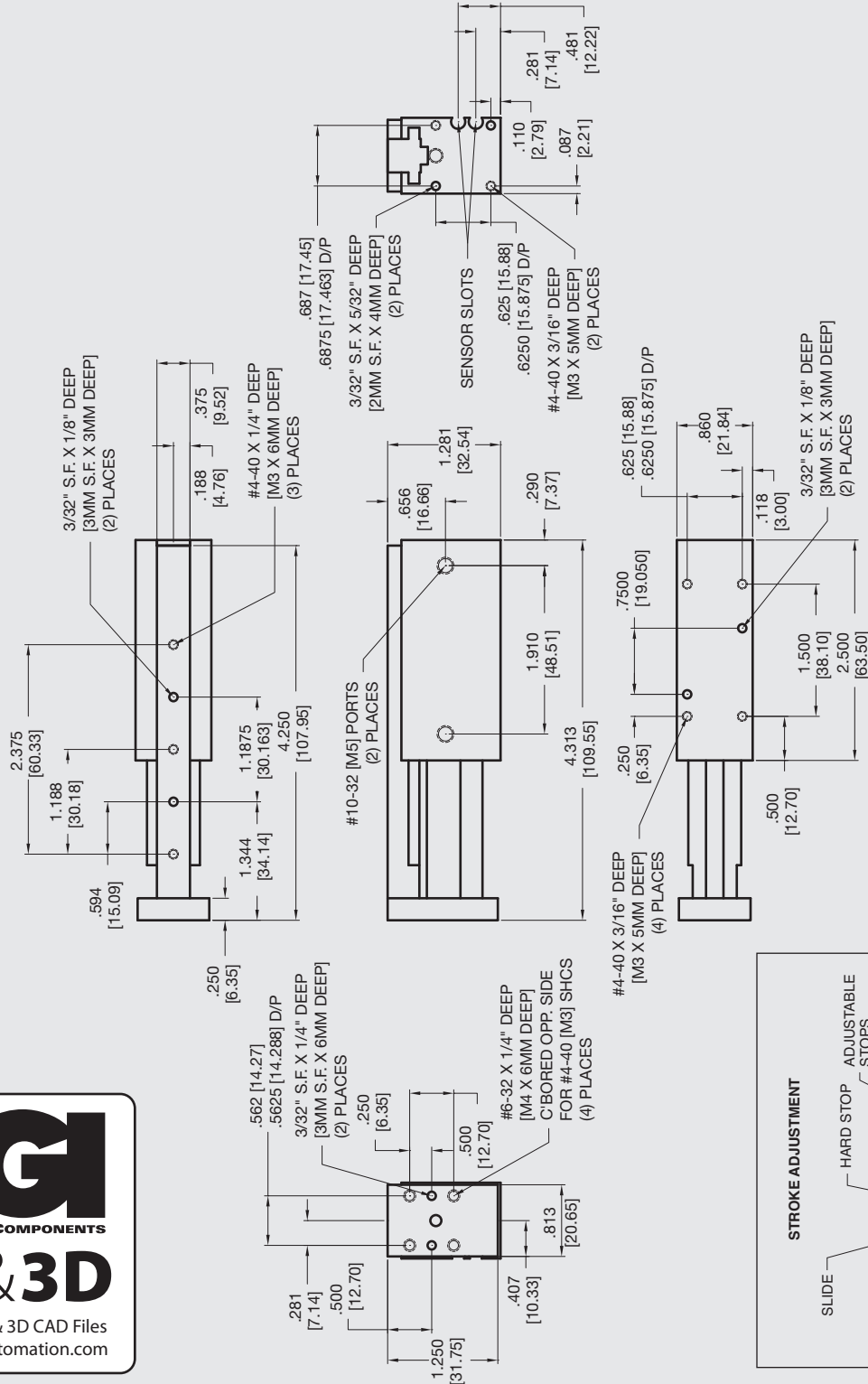

Unless noted, all tolerances are as indicated here:



All Dowel Holes are SF (Slip Fit) Locational Tolerance $\pm .0005"$ [0.13mm]



Metric Threads Course Pitch

Imperial: 0.00 = ± 0.01
Inch 0.000 = ± 0.005
0.0000 = ± 0.0005

Metric: [0.] = ± 0.25
[mm] [0.0] = ± 0.13
[0.00] = ± 0.13



AGMS-1-4 Mini Powered Slide

Built-In Air Cylinder

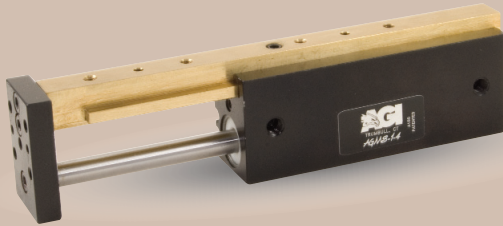

FEATURES AND BENEFITS

- T-Slot bearing support for the carriage and end plate offers superior load bearing performance throughout the stroke.
- Standard built-in stroke adjustment and stroke lock for precise, repetitive operation.
- Compact, lightweight unit with built-in cylinder.
- Piston seals are U-CUP type for long service life.
- Hall Effect sensors are available to monitor stroke position.
- Multiple mounting surfaces on the body and endplate with threaded and counterbored holes for easy mounting choices.

SPECIFICATIONS

Design: Built-in air cylinder
T-slot slide

Stroke: 2.0 in [50.8 mm]

Thrust Force @ 80 PSI [5.5 BAR]

Extended: 15 lbs [66.7 N]
Retract: 13 lbs [57.8 N]

Recommended Speed:

2-12 in/sec
[0.5-.3m/sec]

Pressure Range:

Low/High 20-120 PSI [1.4-8 BAR]

Temperature Range:

Low/High -20°/150°F [-28°/80°C]

Side Play:

± 0.001 [0.03 mm]

Maximum Payload:

18 lbs [81.6 kg]

Material: High Strength, Aluminum Alloys, Bronze

Weight:

5 oz [142 g]

Piston Diameter:

.50 in [12.7 mm]

January 2009 - PATENTED Made in the USA

MAXIMUM FORCES & MOMENTS

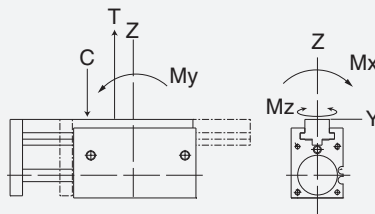

	Static	Dynamic
Max Tensile T	130 lbs [578 N]	55 lbs [244 N]
Max Compressive C	130 lbs [578 N]	55 lbs [244 N]
Max Moment M_x	110 in/lb [12.5 Nm]	50 in/lb [6.7 Nm]
Max Moment M_y	110 in/lb [12.5 Nm]	50 in/lb [6.7 Nm]
Max Moment M_z	110 in/lb [12.5 Nm]	50 in/lb [6.7 Nm]

HOW TO ORDER

When ordering, please specify:
Design/Model Number and Options.

DESIGN/MODEL

- AGMS-1-1
- AGMS-1-2
- AGMS-1-3
- AGMS-1-4

TYPE

- M = METRIC
- = IMPERIAL

SENSOR TYPE

- 1 = NPN
- 2 = PNP

AGMS-1-4 M - 3 - 1 - 1

SENSOR OPTIONS*

- 1 = LEFT
- 2 = RIGHT
- 3 = BOTH

SENSOR CONNECTOR

- 1 = POTTED
- 2 = QUICK DISCONNECT
- 3 = QUICK DISCONNECT WITH RIGHT ANGLE

* NOTE: Hall Effect sensors – Potted or Quick disconnect.

Sensor Part # SHN01, SHP01, SHNQ3, SHPQ3

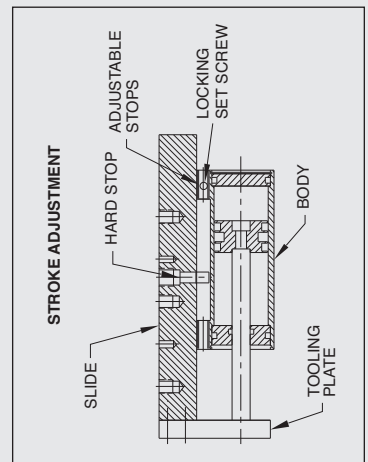
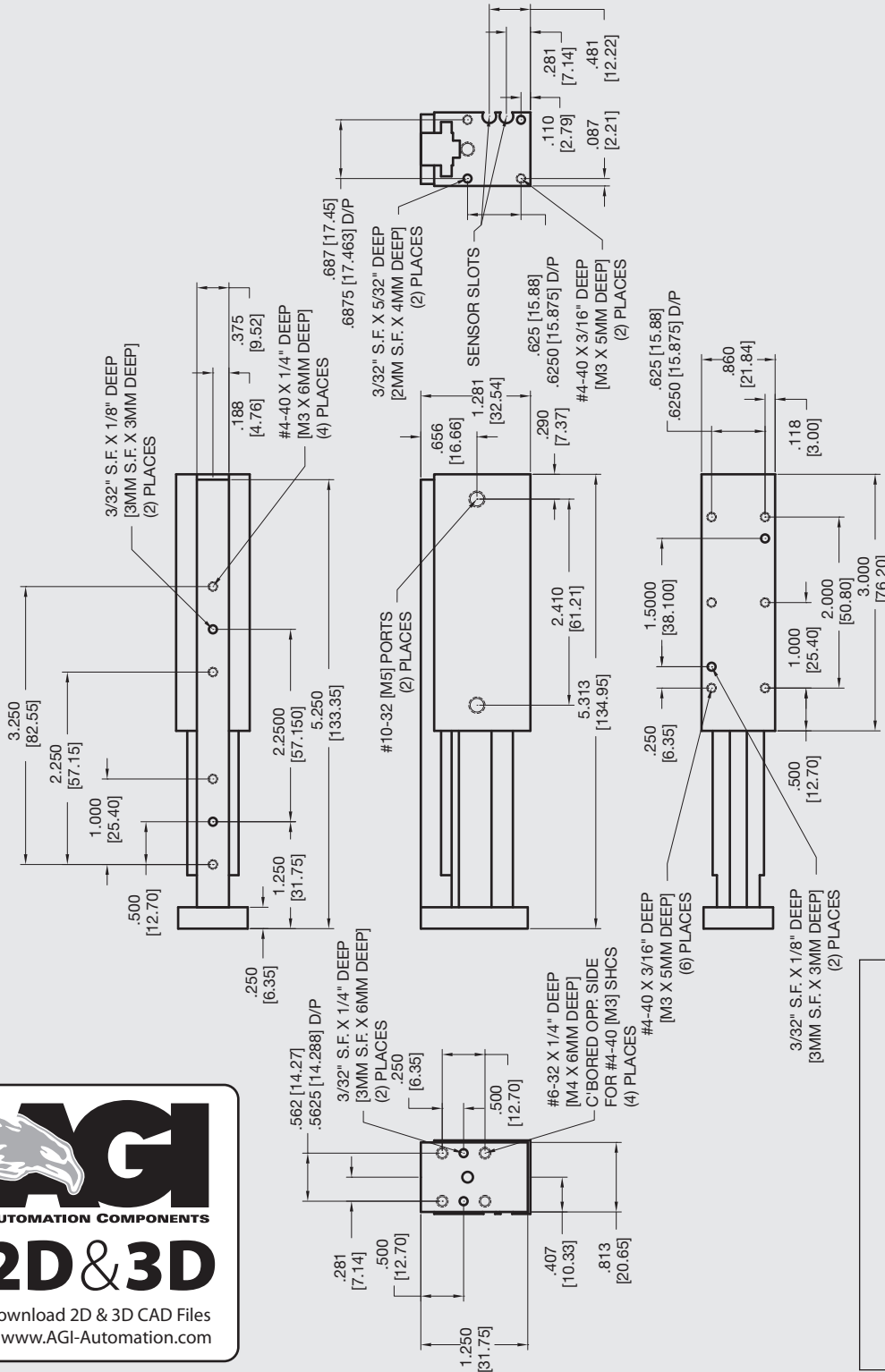

Unless noted, all tolerances are as indicated here:



All Dowel Holes are SF (Slip Fit) Locational Tolerance $\pm .0005$ [0.13mm]



Metric Threads Course Pitch

Imperial:
Inch 0.00 = $\pm .01$
0.000 = $\pm .005$
0.0000 = $\pm .0005$

Metric: [0.] = $\pm .25$
[mm] [0.0] = $\pm .13$
[0.00] = $\pm .013$



AGMS-2-1 Mini Powered Slide

Built-In Air Cylinder

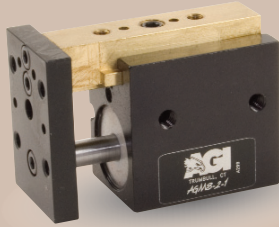

FEATURES AND BENEFITS

- T-Slot bearing support for the carriage and end plate offers superior load bearing performance throughout the stroke.
- Standard built-in stroke adjustment and stroke lock for precise, repetitive operation.
- Compact, lightweight unit with built-in cylinder.
- Piston seals are U-CUP type for long service life.
- Hall Effect sensors are available to monitor stroke position.
- Multiple mounting surfaces on the body and endplate with threaded and counterbored holes for easy mounting choices.

SPECIFICATIONS

Design: Built-in air cylinder
T-slot slide

Stroke: 0.5 in [12.7 mm]

Thrust Force @ 80 PSI [5.5 BAR]

Extended: 35 lbs [155 N]
Retract: 33 lbs [146 N]

Recommended Speed: 2-12 in/sec [0.5-.3m/sec]

Pressure Range: Low/High 20-120 PSI [1.4-8 BAR]

Temperature Range: Low/High -20°/150°F [-28°/80°C]

Side Play: ± 0.001 [0.03 mm]

Maximum Payload: 7 lbs [3.2 kg]

Material: High Strength, Aluminum Alloys, Bronze

Weight: 4.2 oz [120 g]

Piston Diameter: .750 in [19 mm]

January 2009 - PATENTED Made in the USA

MAXIMUM FORCES & MOMENTS

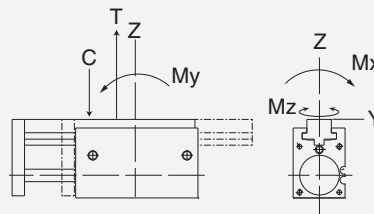

	Static	Dynamic
Max Tensile T	80 lbs [355 N]	34 lbs [151 N]
Max Compressive C	80 lbs [355 N]	34 lbs [151 N]
Max Moment M_x	35 in/lb [3.9 Nm]	19 in/lb [2.2 Nm]
Max Moment M_y	35 in/lb [3.9 Nm]	19 in/lb [2.2 Nm]
Max Moment M_z	35 in/lb [3.9 Nm]	19 in/lb [2.2 Nm]

HOW TO ORDER

When ordering, please specify:
Design/Model Number and Options.

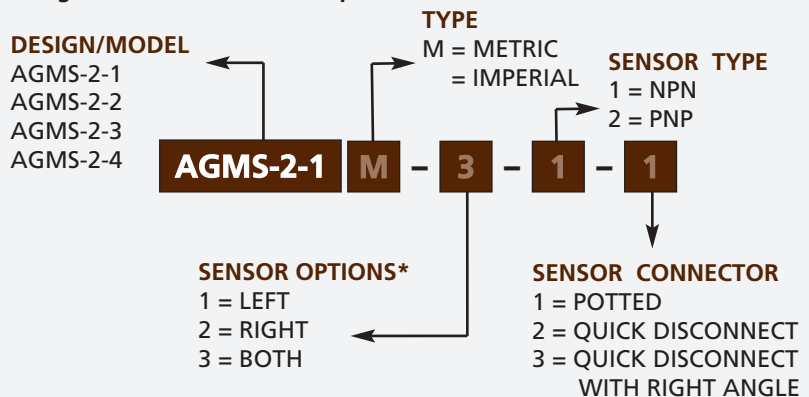

* NOTE: Hall Effect sensors are hard wired with 20" pigtail.

Sensor Part # SHN01, SHP01, SHNQ3, SHPQ3

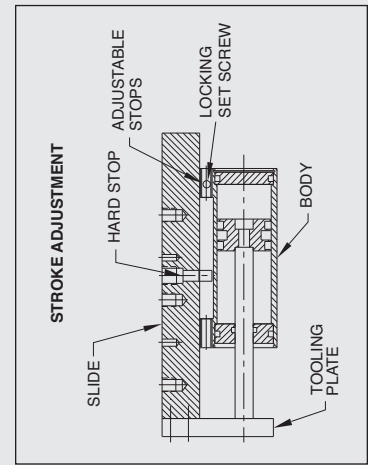
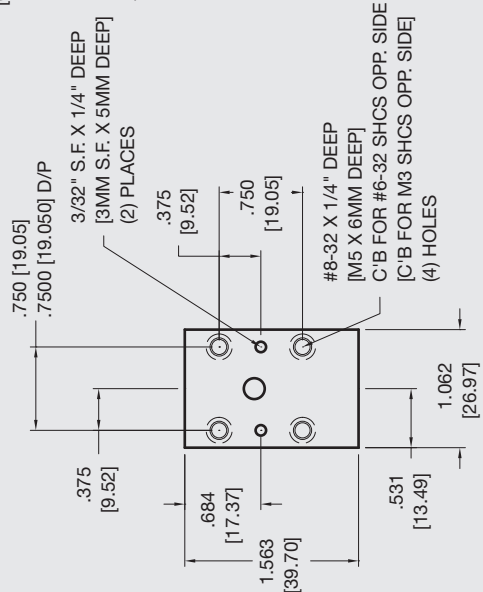
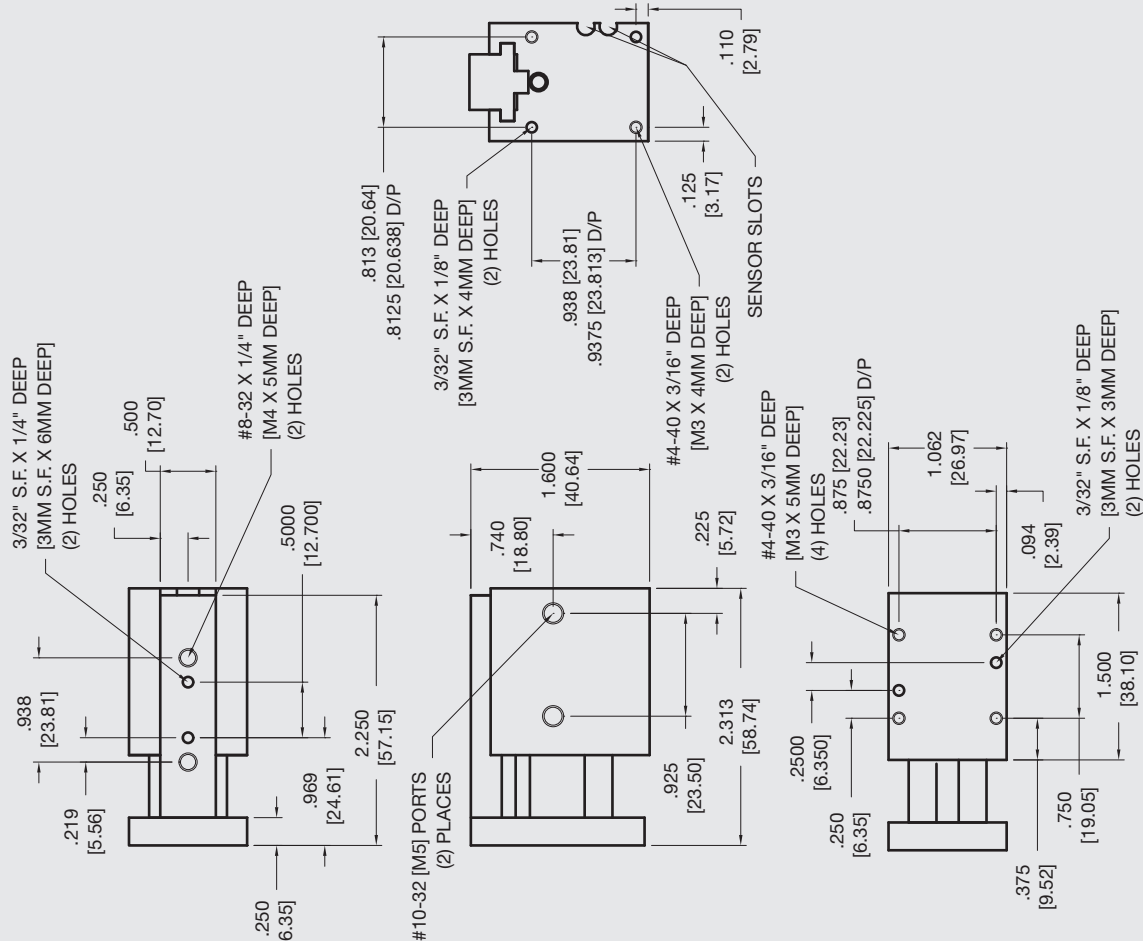

Unless noted, all tolerances are as indicated here:



All Dowel Holes are SF (Slip Fit) Locational Tolerance $\pm .0005$ [0.13mm]



Metric Threads Course Pitch

Imperial:
Inch 0.00 = $\pm .01$
0.000 = $\pm .005$
0.0000 = $\pm .0005$

Metric: [0.] = $\pm .25$
[mm] [0.0] = $\pm .13$
[0.00] = $\pm .013$

AGMS-2-2 Mini Powered Slide

Built-In Air Cylinder

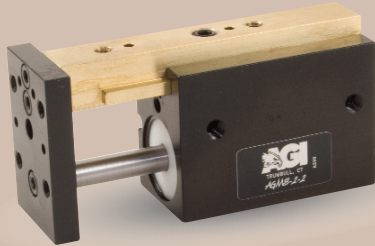

FEATURES AND BENEFITS

- T-Slot bearing support for the carriage and end plate offers superior load bearing performance throughout the stroke.
- Standard built-in stroke adjustment and stroke lock for precise, repetitive operation.
- Compact, lightweight unit with built-in cylinder.
- Piston seals are U-CUP type for long service life.
- Hall Effect sensors are available to monitor stroke position.
- Multiple mounting surfaces on the body and endplate with threaded and counterbored holes for easy mounting choices.

SPECIFICATIONS

Design: Built-in air cylinder
T-slot slide

Stroke: 1 in [25.4 mm]

Thrust Force @ 80 PSI [5.5 BAR]

Extended: 35 lbs [155 N]
Retract: 33 lbs [146 N]

Recommended Speed:

2-12 in/sec
[0.5-.3m/sec]

Pressure Range:

Low/High 20-120 PSI [1.4-8 BAR]

Temperature Range:

Low/High -20°/150°F [-28°/80°C]

Side Play:

± 0.001 [0.03 mm]

Maximum Payload:

13 lbs [5.9 kg]

Material: High Strength, Aluminum Alloys,
Bronze

Weight:

5.6 oz [160 g]

Piston Diameter:

.750 in [19 mm]

January 2009 - PATENTED Made in the USA

MAXIMUM FORCES & MOMENTS

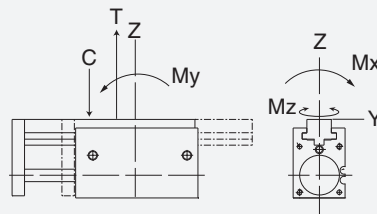

	Static	Dynamic
Max Tensile T	140 lbs [622 N]	60 lbs [266 N]
Max Compressive C	140 lbs [622 N]	60 lbs [266 N]
Max Moment M_x	70 in/lb [8 Nm]	30 in/lb [3.4 Nm]
Max Moment M_y	70 in/lb [8 Nm]	30 in/lb [3.4 Nm]
Max Moment M_z	70 in/lb [8 Nm]	30 in/lb [3.4 Nm]

HOW TO ORDER

When ordering, please specify:
Design/Model Number and Options.

DESIGN/MODEL

AGMS-2-1
AGMS-2-2
AGMS-2-3
AGMS-2-4

TYPE

M = METRIC
= IMPERIAL

SENSOR TYPE

1 = NPN
2 = PNP

AGMS-2-2 M - 3 - 1 - 1

SENSOR OPTIONS*

1 = LEFT
2 = RIGHT
3 = BOTH

SENSOR CONNECTOR

1 = POTTED
2 = QUICK DISCONNECT
3 = QUICK DISCONNECT
WITH RIGHT ANGLE

* NOTE: Hall Effect sensors are hard wired with 20" pigtail.

Sensor Part # SHN01, SHP01, SHNQ3, SHPQ3

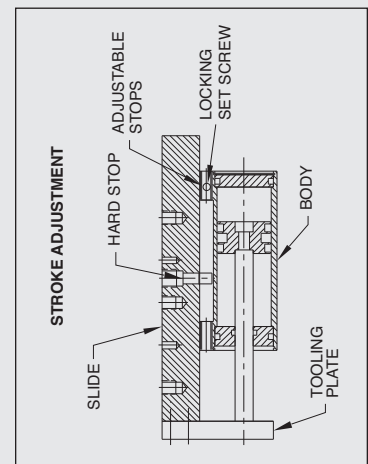
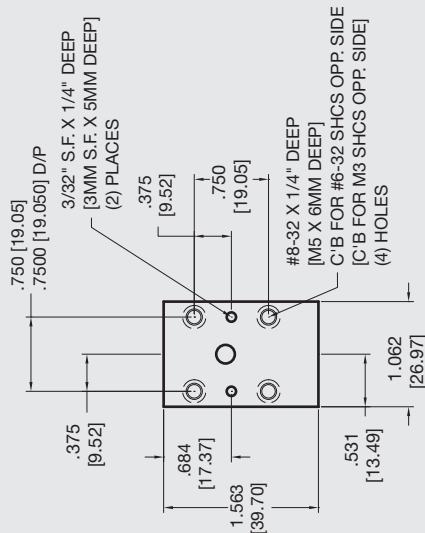
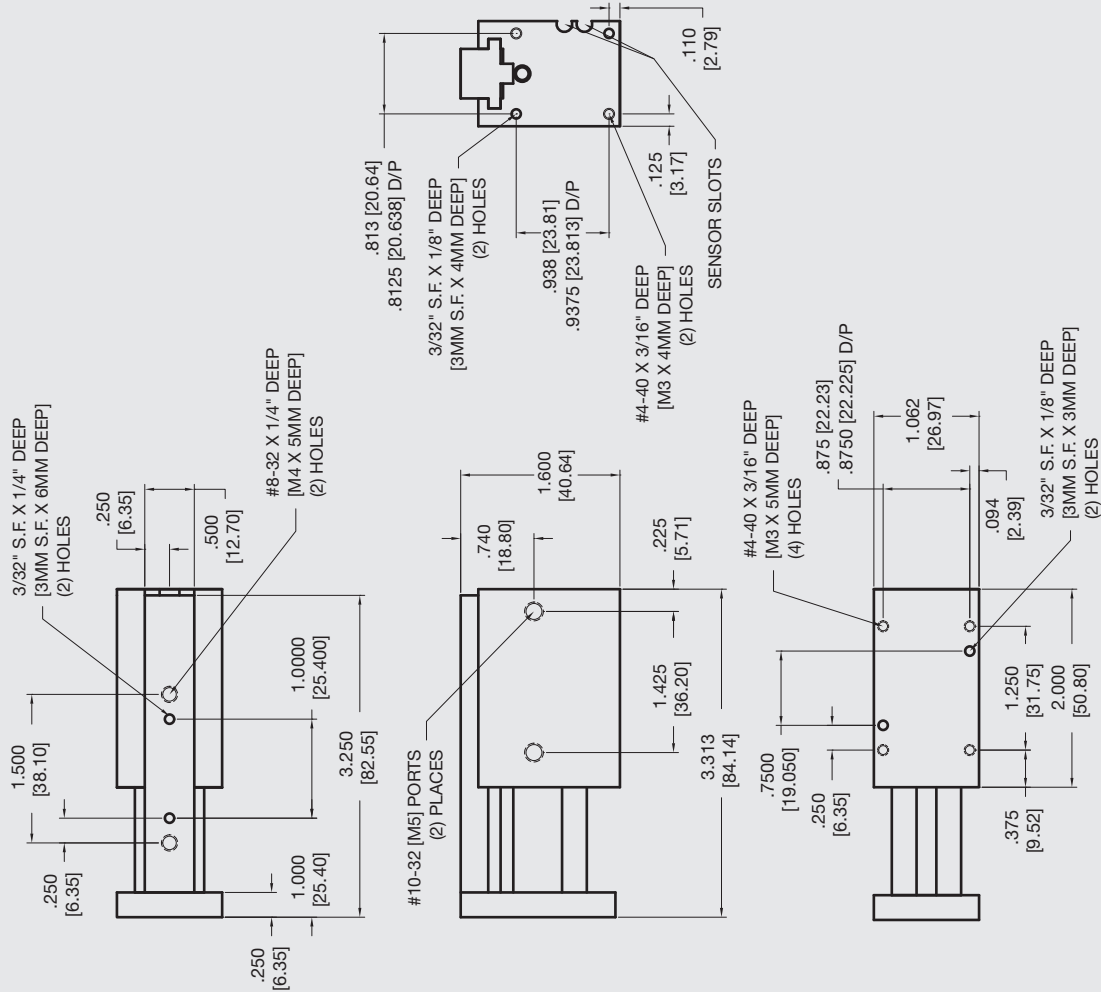

Unless noted, all tolerances are as indicated here:



All Dowel Holes are SF (Slip Fit) Locational Tolerance $\pm .0005"$ [0.13mm]



Metric Threads Course Pitch

Imperial: 0.00 = ± 0.01
Inch 0.000 = ± 0.005
0.0000 = ± 0.0005

Metric: [0.] = ± 0.25
[mm] [0.0] = ± 0.13
[0.00] = ± 0.13



AGMS-2-3 Mini Powered Slide

Built-In Air Cylinder

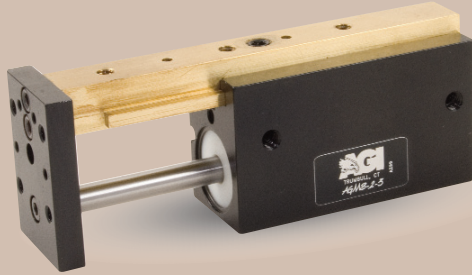

FEATURES AND BENEFITS

- T-Slot bearing support for the carriage and end plate offers superior load bearing performance throughout the stroke.
- Standard built-in stroke adjustment and stroke lock for precise, repetitive operation.
- Compact, lightweight unit with built-in cylinder.
- Piston seals are U-CUP type for long service life.
- Hall Effect sensors are available to monitor stroke position.
- Multiple mounting surfaces on the body and endplate with threaded and counterbored holes for easy mounting choices.

SPECIFICATIONS

Design: Built-in air cylinder
T-slot slide

Stroke: 1.5 in [38.1 mm]

Thrust Force @ 80 PSI [5.5 BAR]

Extended: 35 lbs [155 N]
Retract: 33 lbs [146 N]

Recommended Speed:

2-12 in/sec
[0.5-.3m/sec]

Pressure Range:

Low/High 20-120 PSI [1.4-8 BAR]

Temperature Range:

Low/High -20°/150°F [-28°/80°C]

Side Play:

± 0.001 [0.03 mm]

Maximum Payload:

24 lbs [10.8 kg]

Material: High Strength, Aluminum Alloys,
Bronze

Weight:

6.8 oz [193 g]

Piston Diameter:

.750 in [19 mm]

January 2009 - PATENTED Made in the USA

MAXIMUM FORCES & MOMENTS

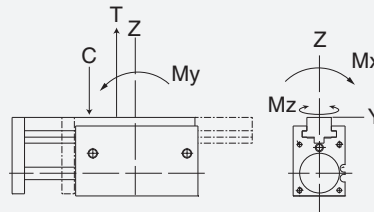

	Static	Dynamic
Max Tensile T	180 lbs [800 N]	77 lbs [342 N]
Max Compressive C	180 lbs [800 N]	77 lbs [342 N]
Max Moment M_x	70 in/lb [8 Nm]	34 in/lb [3.8 Nm]
Max Moment M_y	70 in/lb [8 Nm]	34 in/lb [3.8 Nm]
Max Moment M_z	70 in/lb [8 Nm]	34 in/lb [3.8 Nm]

HOW TO ORDER

When ordering, please specify:
Design/Model Number and Options.

DESIGN/MODEL

AGMS-2-1
AGMS-2-2
AGMS-2-3
AGMS-2-4

TYPE

M = METRIC
= IMPERIAL

SENSOR TYPE

1 = NPN
2 = PNP

AGMS-2-3 **M** - **3** - **1** - **1**

SENSOR OPTIONS*

1 = LEFT
2 = RIGHT
3 = BOTH

SENSOR CONNECTOR

1 = POTTED
2 = QUICK DISCONNECT
3 = QUICK DISCONNECT
WITH RIGHT ANGLE

* NOTE: Hall Effect sensors are hard wired with 20" pigtail.

Sensor Part # SHN01, SHP01, SHNQ3, SHPQ3

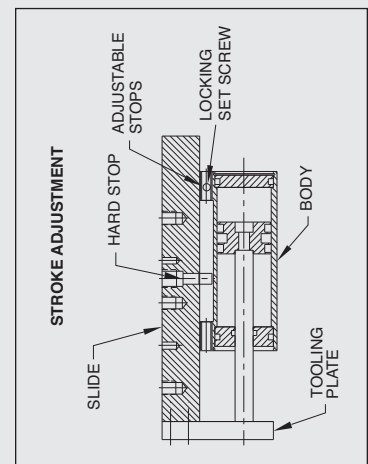
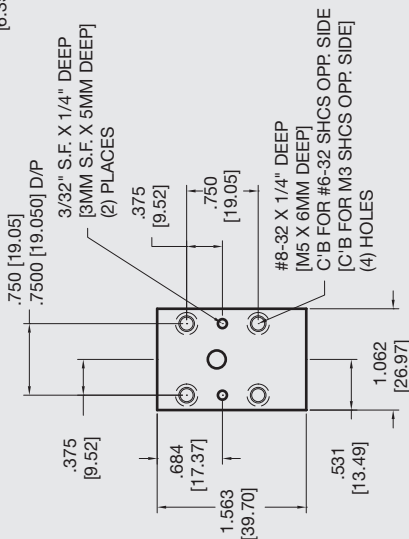
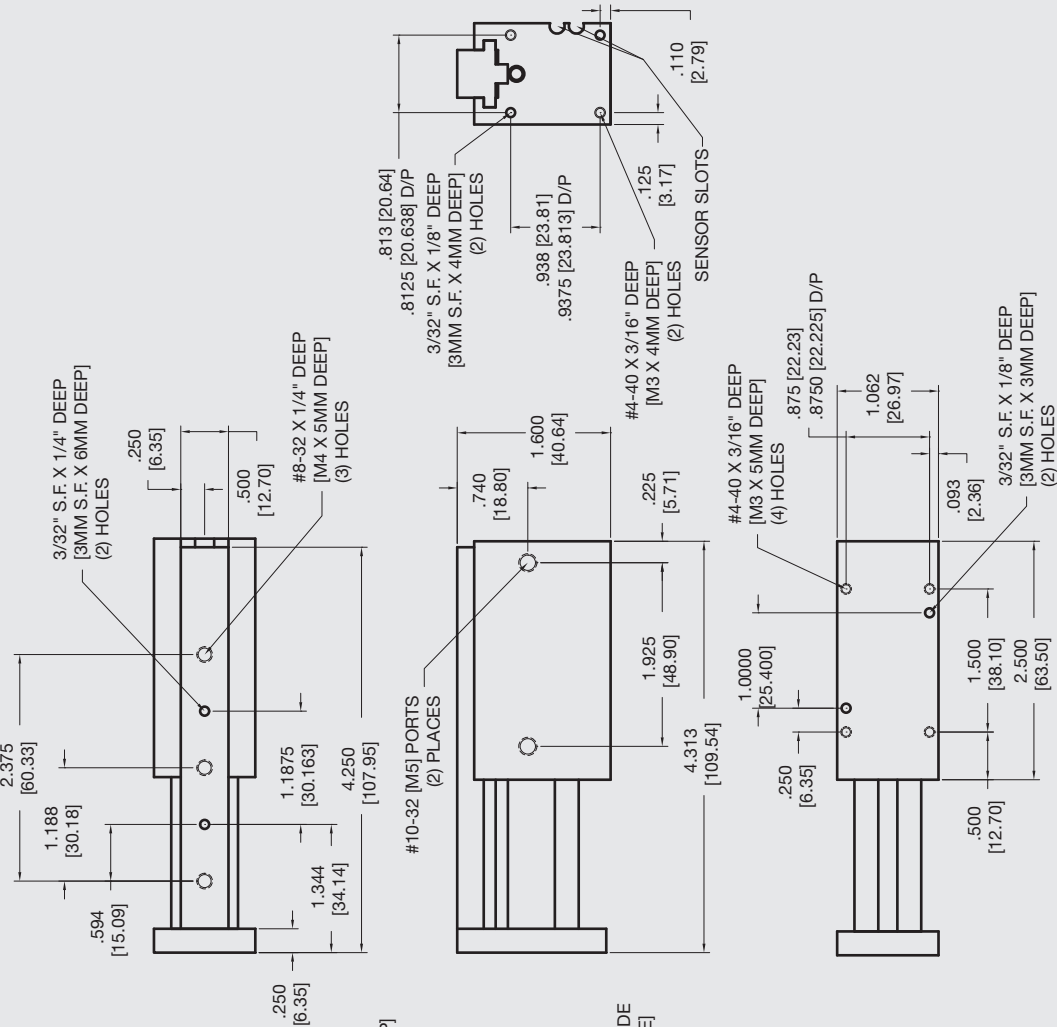

Unless noted, all tolerances are as indicated here:



All Dowel Holes are SF (Slip Fit) Locational Tolerance ± .0005" [0.13mm]



Metric Threads Course Pitch

Imperial:
Inch 0.00 = ±.01
0.000 = ±.005
0.0000 = ±.0005

Metric: [0.] = ±.25
[0.0] = ±.13
[0.00] = ±.013



AGMS-2-4 Mini Powered Slide

Built-In Air Cylinder

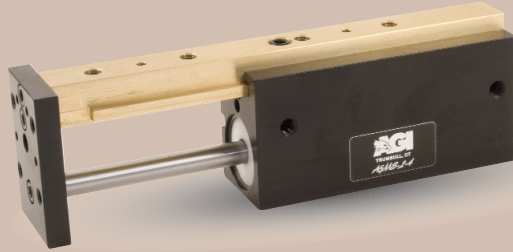

FEATURES AND BENEFITS

- T-Slot bearing support for the carriage and end plate offers superior load bearing performance throughout the stroke.
- Standard built-in stroke adjustment and stroke lock for precise, repetitive operation.
- Compact, lightweight unit with built-in cylinder.
- Piston seals are U-CUP type for long service life.
- Standard built-in stroke adjustment and stroke lock for precise, repetitive operation.
- Hall Effect sensors are available to monitor stroke position.
- Multiple mounting surfaces on the body and endplate with threaded and counterbored holes for easy mounting choices.

SPECIFICATIONS

Design: Built-in air cylinder
T-slot slide

Stroke: 2 in [50.8 mm]

Thrust Force @ 80 PSI [5.5 BAR]

Extended: 35 lbs [155 N]
Retract: 33 lbs [146 N]

Recommended Speed: 2-12 in/sec [0.5-.3m/sec]

Pressure Range: Low/High 20-120 PSI [1.4-8 BAR]

Temperature Range: Low/High -20°/150°F [-28°/80°C]

Side Play: ± 0.001 [0.03 mm]

Maximum Payload: 30 lbs [13.6 kg]

Material: High Strength, Aluminum Alloys, Bronze

Weight: 8.4 oz [240 g]

Piston Diameter: .750 in [19 mm]

January 2009 - PATENTED Made in the USA

MAXIMUM FORCES & MOMENTS

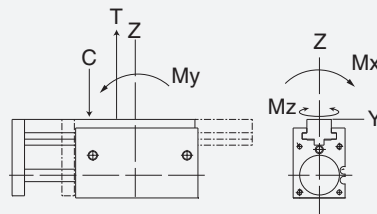

	Static	Dynamic
Max Tensile T	250 lbs [1112 N]	108 lbs [800 N]
Max Compressive C	250 lbs [1112 N]	108 lbs [800 N]
Max Moment M_x	120 in/lb [8 Nm]	62 in/lb [7 Nm]
Max Moment M_y	120 in/lb [8 Nm]	62 in/lb [7 Nm]
Max Moment M_z	120 in/lb [8 Nm]	62 in/lb [7 Nm]

HOW TO ORDER

When ordering, please specify:
Design/Model Number and Options.

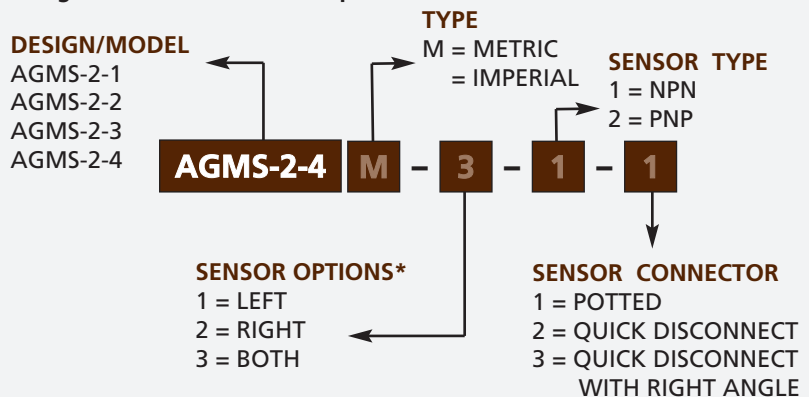

* NOTE: Hall Effect sensors are hard wired with 20" pigtail.
Sensor Part # SHN01, SHP01, SHNQ3, SHPQ3

AGMS-2-4 Mini Powered Slide

Built-In Air Cylinder

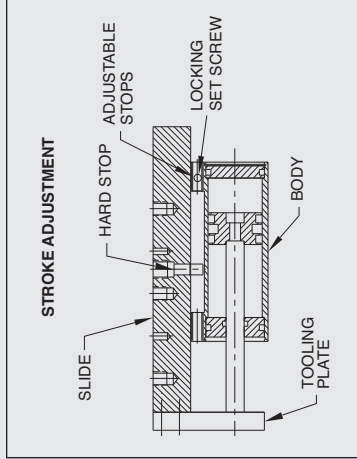
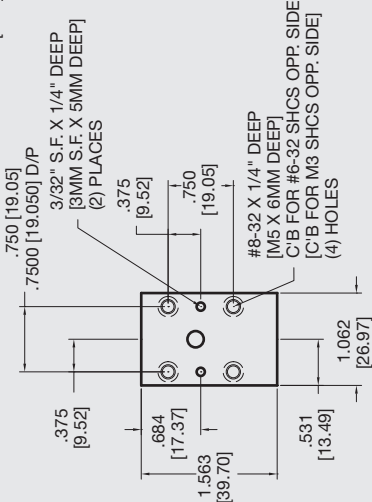
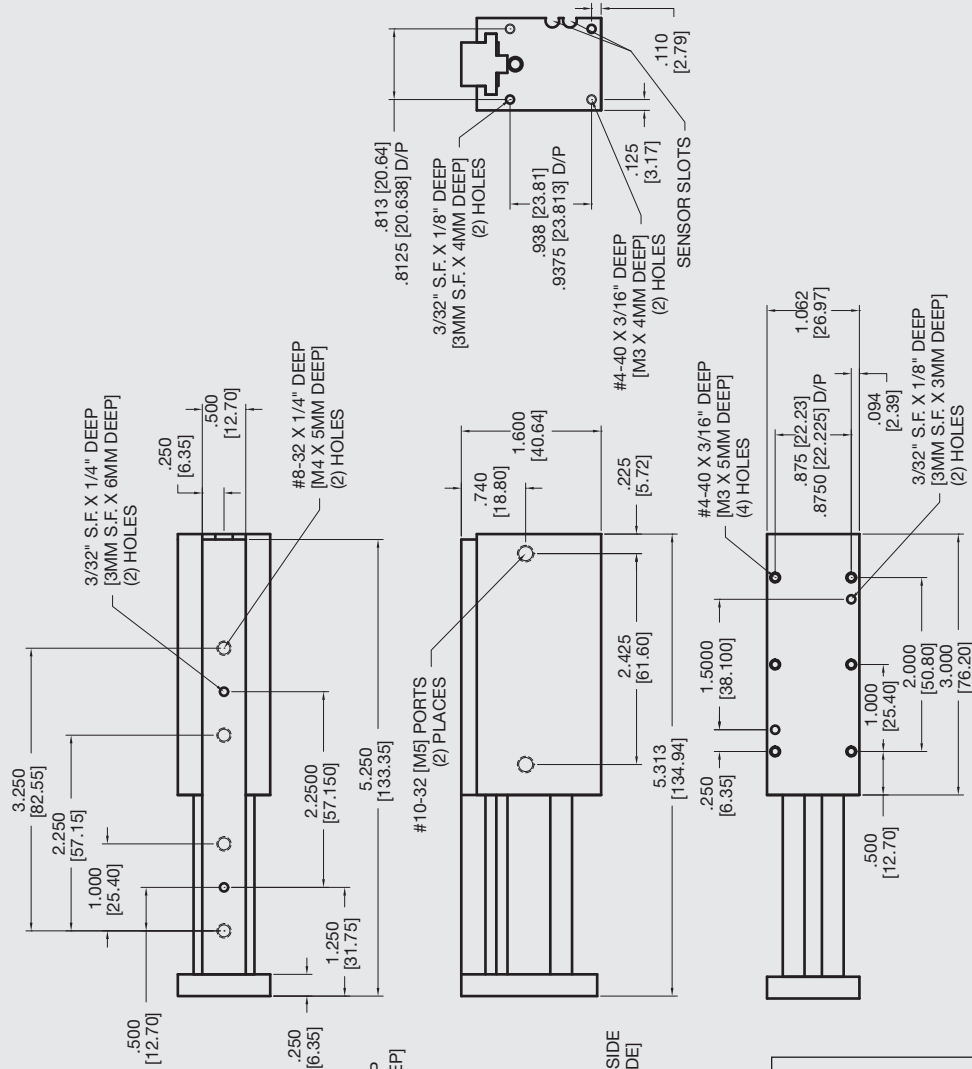

Unless noted, all tolerances are as indicated here:



All Dowel Holes are SF (Slip Fit) Locational Tolerance ± .0005" [0.13mm]



Metric Threads Course Pitch

Imperial:
 Inch 0.00 = ±.01
 0.000 = ±.005
 0.0000 = ±.0005

Metric: [0.] = ±.25
 [mm] [0.0] = ±.13
 [0.00] = ±.013



AGS-4 Powered Slide

Built-In Air Cylinder

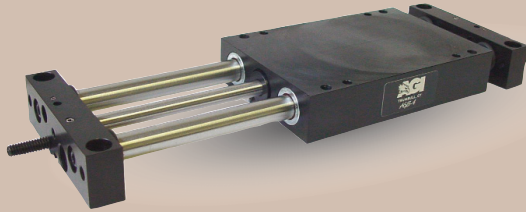

FEATURES AND BENEFITS

- Compact lightweight unit with built-in air cylinder.
- Linear ball bearings ride on precision hardened ground steel shafts.
- Units are permanently lubricated.
- Pistons seals are U-Cup type for long service life.
- Aluminum body and end blocks contain tapped holes and dowel pin holes for precision mounting or fixturing.
- Custom mounting holes and air ports can be added. Please consult factory.
- Main body or end blocks can be anchored due to the 1/16" height clearance.
- Standard built-in stroke adjustment for precise repetitive operation.
- Proximity switches are available to monitor end of stroke position of the body.
- Optional shock absorbers can be ordered for smooth operation.
- Series AGS is fully field repairable for cost savings and minimum down time. Repair kits are available for repairs or maintenance.

SPECIFICATIONS: AGS-4

Design: Built-in air cylinder, linear bearings on steel hardened shafts

Stroke: 1 to 4 in [25.4 mm to 101 mm]

Thrust Force @ 80 PSI [5.5 BAR]
25 lbs [111 N]

Recommended Speed: 2-14 in/sec [0.5-.35 m/sec]

Pressure Range:
Low/High 20-120 PSI [1.4-8 BAR]

Temperature Range:
Low/High -20°/150°F [-28°/80°C]

Side Play: ± 0.001 [.03 mm]

Maximum Payload: 25 lbs [11.3 kg]

Material: High Strength, Aluminum Alloys, Steel Components

Weight: 3.5 lbs [1.6 kg]

Piston Diameter: .750 in [19 mm]

SPECIFICATIONS: AGS-4-X

Custom Stroke: X= 0 to 4 in [101.6 mm]

All Other Specifications: Same As Above

PAYLOAD DATA

Max Tensile T	90 lbs	[400 N]
Max Compressive C	90 lbs	[400 N]
Max Moment M_x	220 in/lb	[25 Nm]
Max Moment M_y	220 in/lb	[25 Nm]
Max Moment M_z	220 in/lb	[25 Nm]

Deflection @ Max load 0.003
Maximum Payload (25 lbs)
Recommended load for smooth operation.

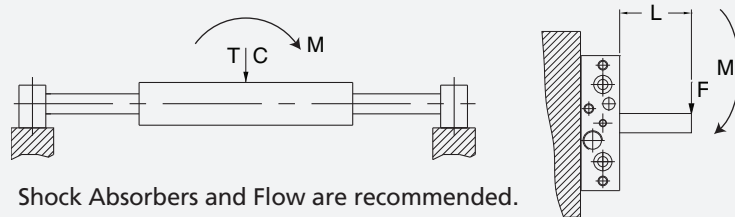

HOW TO ORDER

When ordering, please specify:
Design/Model Number and Options.

DESIGN/MODEL

AGS-4
AGS-5
AGS-6

SENSOR OPTIONS

1 = LEFT
2 = RIGHT
3 = BOTH

SENSOR TYPE*

1 = NPN
2 = PNP

SHOCK ABSORBERS

AGS-4 M - 4 - 3 - 1 - 1 - S

TYPE
M = METRIC
= IMPERIAL

SENSOR CONNECTOR

1 = POTTED
2 = QUICK DISCONNECT
3 = QUICK DISCONNECT WITH RIGHT ANGLE

AGS-4 STROKE (1", 2", 3", 4")
AGS-5 STROKE (1", 2", 3", 4", 5")
AGS-6 STROKE (1", 2", 3", 4", 5", 6")

* NOTE: Proximity sensors are 8 mm diam., 12-30 VDC, 50 mA and come with 2 meter cable.

Sensor Part # SNC08, SNQ08, SPC08, SPQ08

January 2009 - PATENTED Made in the USA

CUSTOM MOUNTING AREA

NOTE: The end blocks and body can be drilled and tapped from top of back side.
 Shaded area available for custom drilling and tapping.
 For drilling and tapping end blocks, please consult the factory.

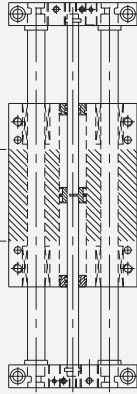

WARNING! Do not exceed mounting screw depth. LOOK! More Technical specifications for sensors on "Sensors Accessories" page.

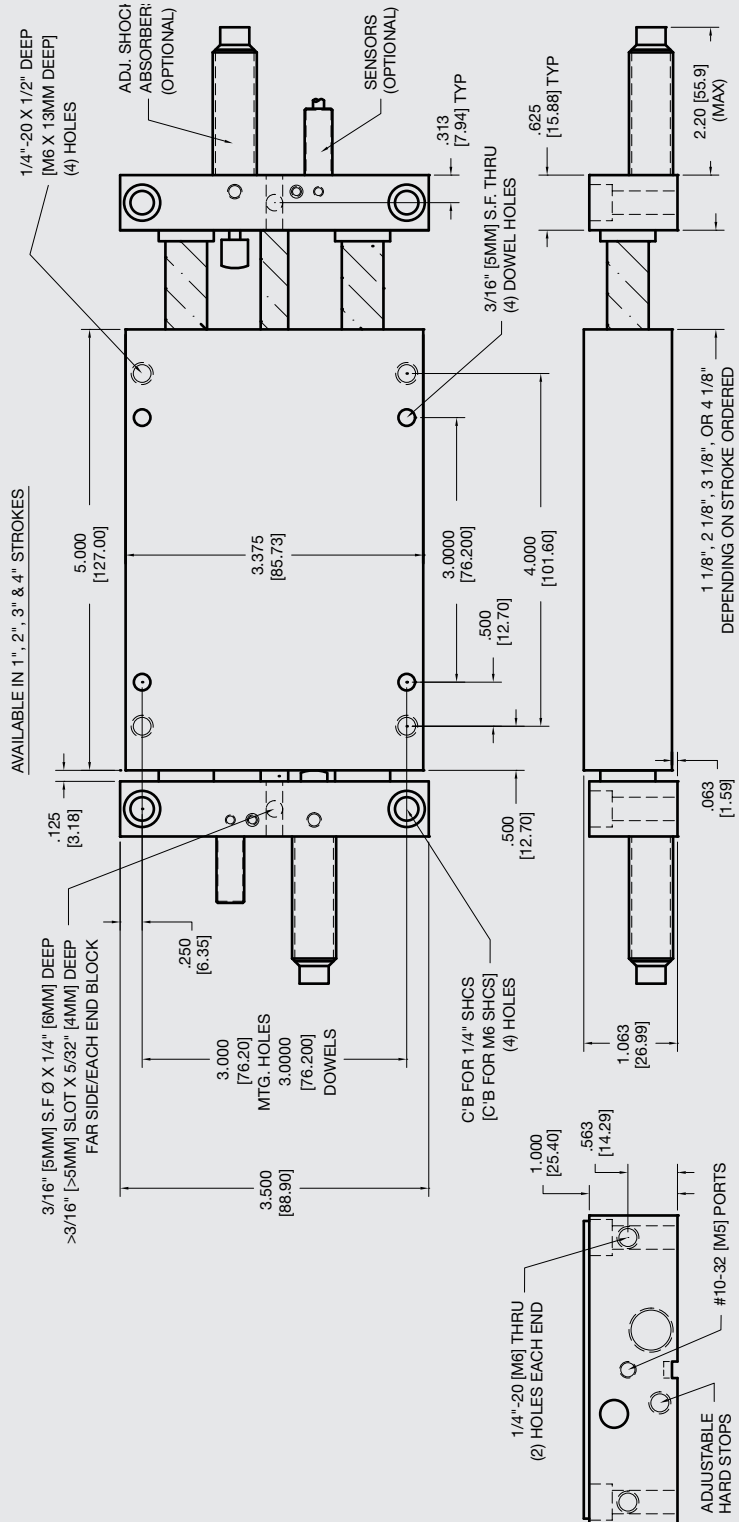

Download 2D & 3D CAD Files
 @ www.AGI-Automation.com

Unless noted, all tolerances are as indicated here:



All Dowel Holes are SF (Slip Fit) Locational Tolerance $\pm .0005$ " [0.13mm]



Metric Threads Course Pitch

Imperial:
 Inch 0.00 = $\pm .01$
 0.000 = $\pm .005$
 0.0000 = $\pm .0005$

Metric:
 [0.] = $\pm .25$
 [0.0] = $\pm .13$
 [0.00] = $\pm .013$



AGS-5 Powered Slide

Built-In Air Cylinder

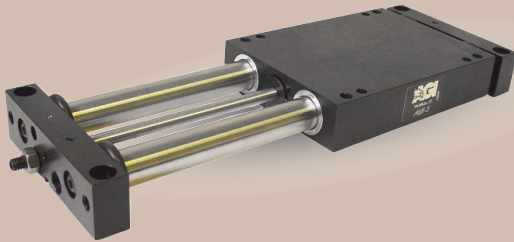

FEATURES AND BENEFITS

- Compact lightweight unit with built-in air cylinder.
- Linear ball bearings ride on precision hardened ground steel shafts.
- Units are permanently lubricated.
- Pistons seals are U-Cup type for long service life.
- Aluminum body and end blocks contain tapped holes and dowel pin holes for precision mounting or fixturing.
- Custom mounting holes and air ports can be added. Please consult factory.
- Main body or end blocks can be anchored due to the 1/16" height clearance.
- Standard built-in stroke adjustment for precise repetitive operation.
- Proximity switches are available to monitor end of stroke position of the body.
- Optional shock absorbers can be ordered for smooth operation.
- Series AGS is fully field repairable for cost savings and minimum down time. Repair kits are available for repairs or maintenance.

SPECIFICATIONS: AGS-5

Design: Built-in air cylinder, linear bearings on steel hardened shafts

Stroke: 5 in

Thrust Force @ 80 PSI [5.5 BAR]

50 lbs [222 N]

Recommended Speed:

2-14 in/sec
[0.5-.35 m/sec]

Pressure Range:
Low/High

20-120 PSI [1.4-8 BAR]

Temperature Range:

Low/High -20°/150°F [-28°/80°C]

Side Play:

± 0.001 [.03 mm]

Maximum Payload:

50 lbs [22.6 kg]

Material: High Strength, Aluminum Alloys, Steel Components

Weight:

6.5 lbs [3 kg]

Piston Diameter:

1.0 in [25 mm]

SPECIFICATIONS: AGS-5-X

Custom Stroke: X= 0 to 5 in [XXX mm]

All Other Specifications: Same As Above

PAYLOAD DATA

Max Tensile T	150 lbs	[667 N]
Max Compressive C	150 lbs	[667 N]
Max Moment M_x	550 in/lb	[62 Nm]
Max Moment M_y	550 in/lb	[62 Nm]
Max Moment M_z	550 in/lb	[62 Nm]

Deflection @ Max load 0.003
Maximum Payload (50 lbs)
Recommended load for smooth operation.

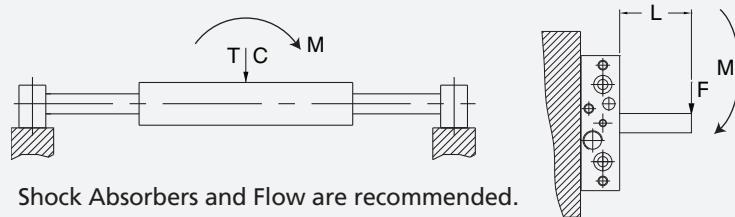

HOW TO ORDER

When ordering, please specify:
Design/Model Number and Options.

DESIGN/MODEL

AGS-4
AGS-5
AGS-6

SENSOR OPTIONS

1 = LEFT
2 = RIGHT
3 = BOTH

SENSOR TYPE*

1 = NPN
2 = PNP

SHOCK ABSORBERS

AGS-5 M - 5 - 3 - 1 - 1 - S

TYPE

M = METRIC
= IMPERIAL

SENSOR CONNECTOR

1 = POTTED
2 = QUICK DISCONNECT
3 = QUICK DISCONNECT WITH RIGHT ANGLE

AGS-4 STROKE (1", 2", 3", 4")
AGS-5 STROKE (1", 2", 3", 4", 5")
AGS-6 STROKE (1", 2", 3", 4", 5", 6")

* NOTE: Proximity sensors are 8 mm diam., 12-30 VDC, 50 mA and come with 2 meter cable.

Sensor Part # SNC08, SNQ08, SPC08, SPQ08

January 2009 - PATENTED Made in the USA

CUSTOM MOUNTING AREA

NOTE: The end blocks and body can be drilled and tapped from top of back side.
 Shaded area available for custom drilling and tapping.
 For drilling and tapping end blocks, please consult the factory.

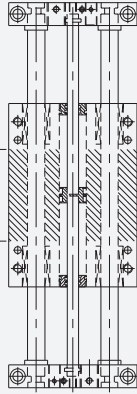

WARNING! Do not exceed mounting screw depth. **LOOK!** More Technical specifications for sensors on "Sensors Accessories" page.

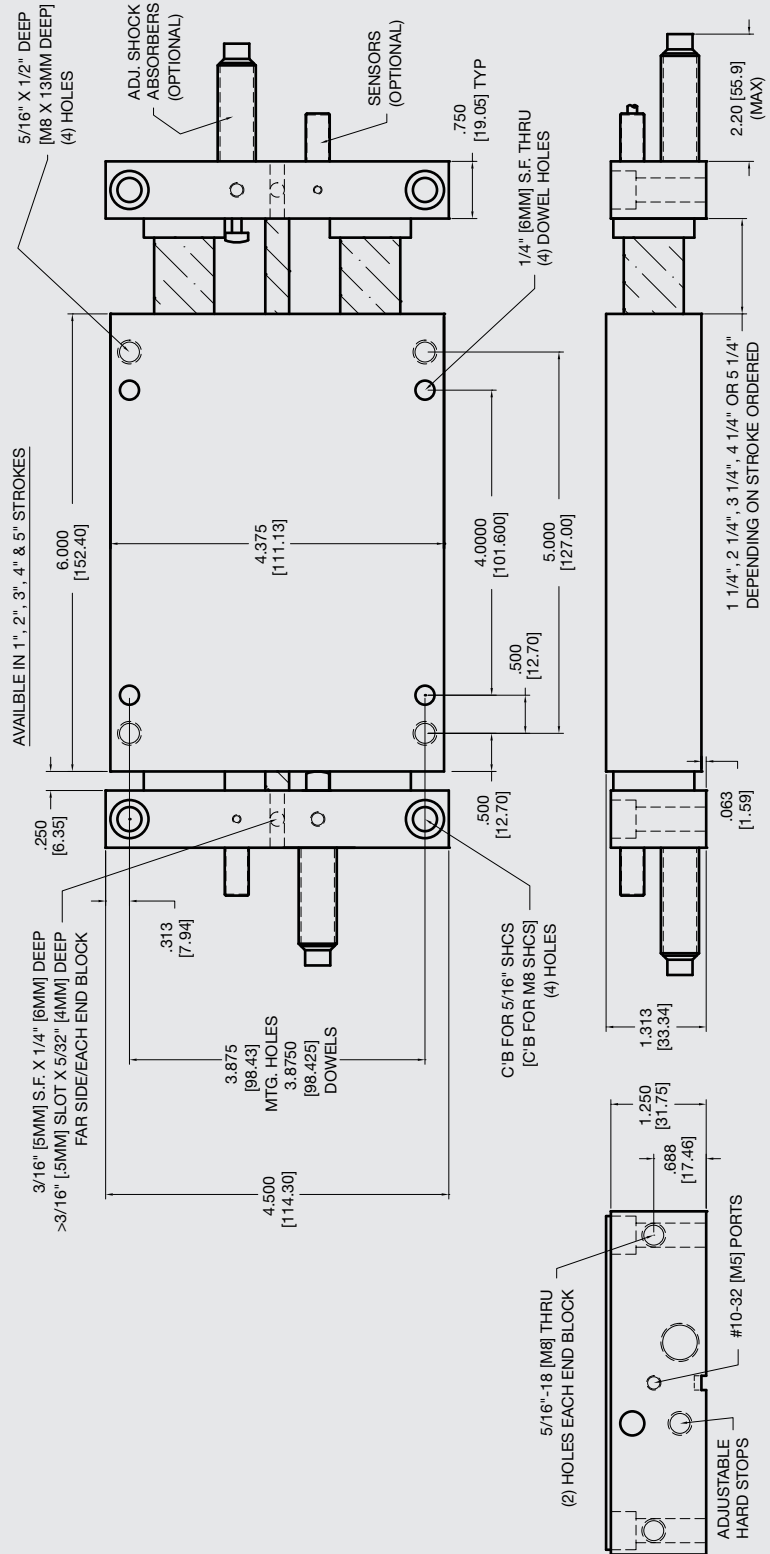

Download 2D & 3D CAD Files
 @ www.AGI-Automation.com

Unless noted, all tolerances are as indicated here:



All Dowel Holes are SF (Slip Fit) Locational Tolerance ± .0005" [0.13mm]



Metric Threads Course Pitch

Imperial:
 Inch 0.00 = ±0.01
 0.000 = ±0.005
 0.0000 = ±0.0005

Metric:
 [0.] = ±.25
 [0.0] = ±.13
 [0.00] = ±0.13

AGS-6 Powered Slide

Built-In Air Cylinder

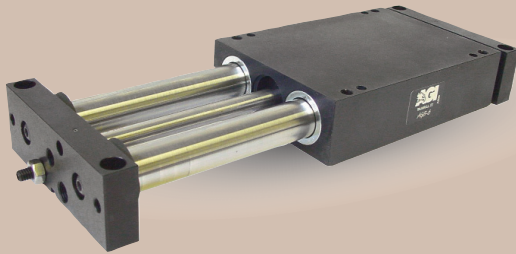

FEATURES AND BENEFITS

- Compact lightweight unit with built-in air cylinder.
- Linear ball bearings ride on precision hardened ground steel shafts.
- Units are permanently lubricated.
- Pistons seals are U-Cup type for long service life.
- Aluminum body and end blocks contain tapped holes and dowel pin holes for precision mounting or fixturing.
- Custom mounting holes and air ports can be added. Please consult factory.
- Main body or end blocks can be anchored due to the 1/16" height clearance.
- Standard built-in stroke adjustment for precise repetitive operation.
- Proximity switches are available to monitor end of stroke position of the body.
- Optional shock absorbers can be ordered for smooth operation.
- Series AGS is fully field repairable for cost savings and minimum down time. Repair kits are available for repairs or maintenance.

SPECIFICATIONS: AGS-6

Design: Built-in air cylinder, linear bearings on steel hardened shafts

Stroke: 1-6 in

Thrust Force @ 80 PSI [5.5 BAR]

80 lbs [355 N]

Recommended Speed:

2-14 in/sec
[0.5-35 m/sec]

Pressure Range:
Low/High

20-120 PSI [1.4-8 BAR]

Temperature Range:

Low/High -20°/150°F [-28°/80°C]

Side Play:

± 0.001 [0.03 mm]

Maximum Payload: 100 lbs [45.3 kg]

Material: High Strength, Aluminum Alloys, Steel Components

Weight:

12 lbs [5.5 kg]

Piston Diameter:

1.25 in [31.7 mm]

SPECIFICATIONS: AGS-6-X

Custom Stroke: X= 0 to 6 in [152 mm]

All Other Specifications: Same As Above

PAYLOAD DATA

Max Tensile T	220 lbs	[980 N]
Max Compressive C	220 lbs	[980 N]
Max Moment M_x	1000 in/lb	[113 Nm]
Max Moment M_y	1000 in/lb	[113 Nm]
Max Moment M_z	1000 in/lb	[113 Nm]

Deflection @ Max load 0.003
Maximum Payload (100 lbs)
Recommended load for smooth operation.

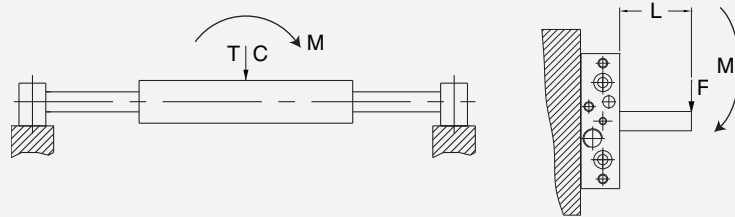

HOW TO ORDER

When ordering, please specify:
Design/Model Number and Options.

DESIGN/MODEL

AGS-4
AGS-5
AGS-6

SENSOR OPTIONS

1 = LEFT
2 = RIGHT
3 = BOTH

SENSOR TYPE*

1 = NPN
2 = PNP

SHOCK ABSORBERS

AGS-6 M - 6 - 3 - 1 - 1 - S

TYPE
M = METRIC
= IMPERIAL

SENSOR CONNECTOR

1 = POTTED
2 = QUICK DISCONNECT
3 = QUICK DISCONNECT WITH RIGHT ANGLE

AGS-4 STROKE (1", 2", 3", 4")
AGS-5 STROKE (1", 2", 3", 4", 5")
AGS-6 STROKE (1", 2", 3", 4", 5", 6")

* NOTE: Proximity sensors are 8 mm diam., 12-30 VDC, 50 mA and come with 2 meter cable.

Sensor Part # SNC08, SNQ08, SPC08, SPQ08

January 2009 - PATENTED Made in the USA

CUSTOM MOUNTING AREA

NOTE: The end blocks and body can be drilled and tapped from top of back side.
Shaded area available for custom drilling and tapping.
For drilling and tapping end blocks, please consult the factory.

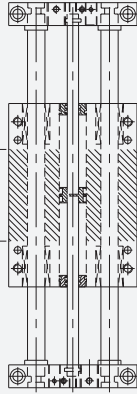

WARNING! Do not exceed mounting screw depth. LOOK! More Technical specifications for sensors on "Sensors Accessories" page.

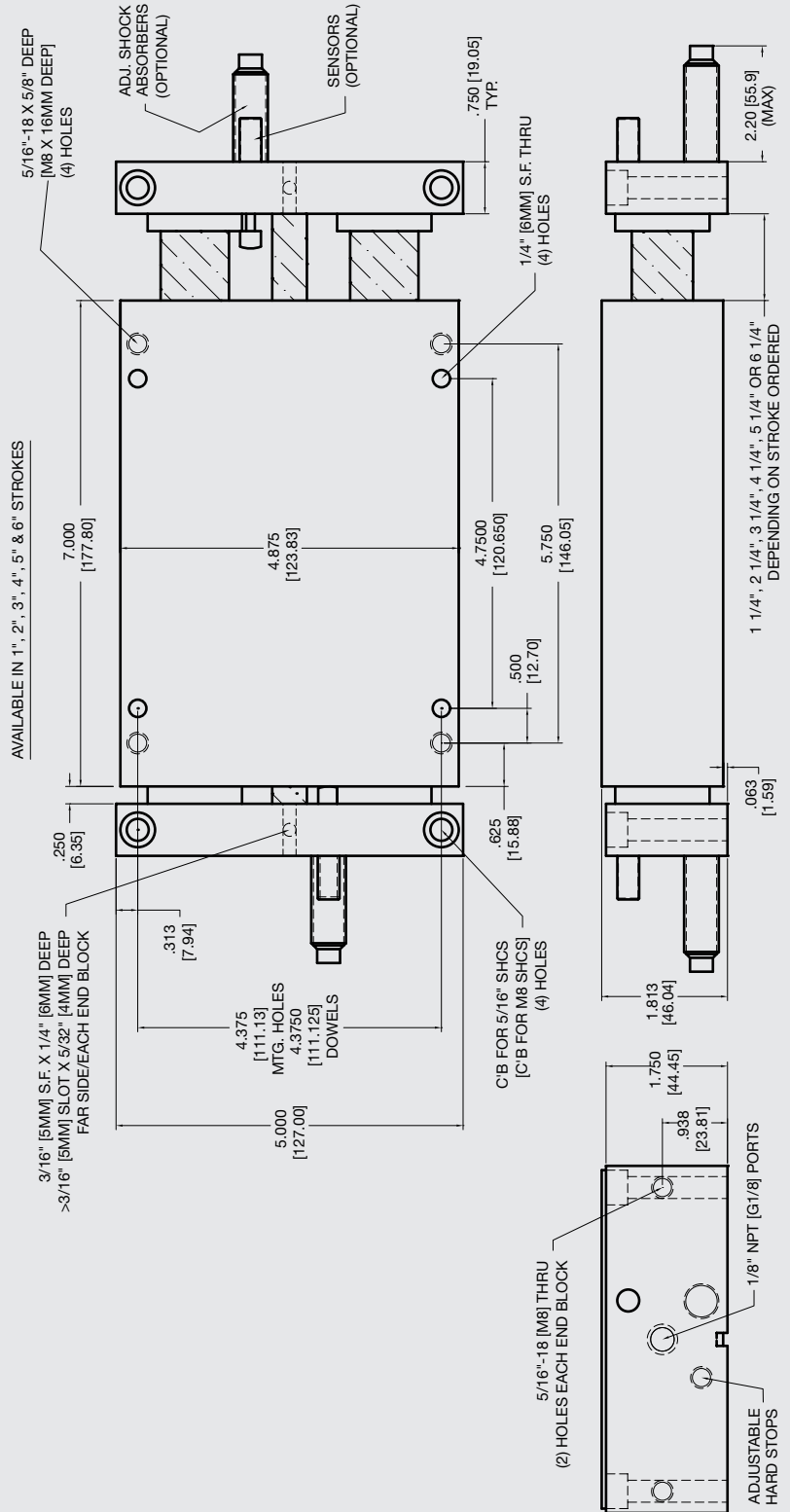

Unless noted, all tolerances are as indicated here:



All Dowel Holes are SF (Slip Fit) Locational Tolerance ± .0005" [.013mm]



Metric Threads Course Pitch

Imperial:
Inch 0.00 = ±.01
0.000 = ±.005
0.0000 = ±.0005

Metric: [0.] = ±.25
[0.0] = ±.13
[0.00] = ±.013



AGT-2 Powered Slide Linear Thruster



FEATURES AND BENEFITS

- Floating piston rod coupling eliminates cylinder binding.
- Compact, lightweight unit with replaceable air-cylinder.
- Units are permanently lubricated.
- Optional stroke adjustment for precise, repetitive operation.
- Proximity switches are available to monitor end of stroke position of the body.
- Optional shock absorbers can be ordered for smooth operation.
- Aluminum body end blocks contain taped holes and dowel pin holes for precision mounting or fixturing.
- Standard end plate to stop shaft vibrations.

SPECIFICATIONS

Design: Replaceable air cylinder, linear bearings on steel hardened shafts

Stroke: 4 in max. (1" increments)
[100 mm] [25.4 mm]

Thrust Force @ 80 PSI [5.5 BAR]

30 lbs (multiply force factor by input pressure in PSI)

Extended: 20 lbs [89 N]

Retract: 19 lbs [85 N]

Recommended Speed:

1-40 in/sec

Pressure Range:

Low/High 20-120 PSI [1.4-8 BAR]

Temperature Range:

Low/High -20°/150°F [-28°/80°C]

Side Play: ± 0.001 [0.03 mm]

Deflection: See Chart

Maximum Payload: 5 lbs [2.2 kg]

Material: High Strength, Aluminum Alloys, Steel Components

Weight: 0.50 lbs + 0.05 lb/in
[0.23 kg + 0.86 g/mm]

Shaft Diameter: 3/16 in [5 mm]

Piston Diameter: 9/16 in [14 mm]

January 2009 - PATENTED Made in the USA

PAYLOAD FORCES

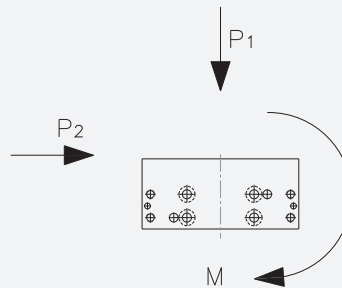

WARNING! Do not exceed mounting screw depth.

LOOK! More Technical specifications for sensors on "Sensors Accessories" page.

HOW TO ORDER

When ordering, please specify:
Design/Model Number and Options.

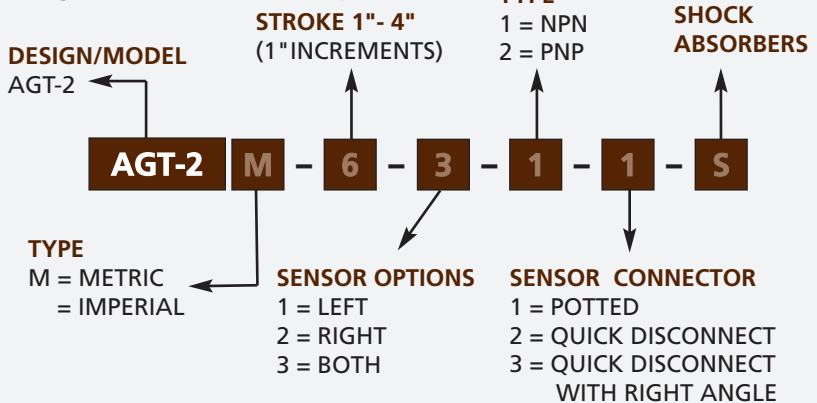

* NOTE: Proximity sensors are 8 mm diam., 12-30 VDC, 50 mA and come with 2 meter cable.

Sensor Part # SNC08, SNQ08, SPC08, SPQ08

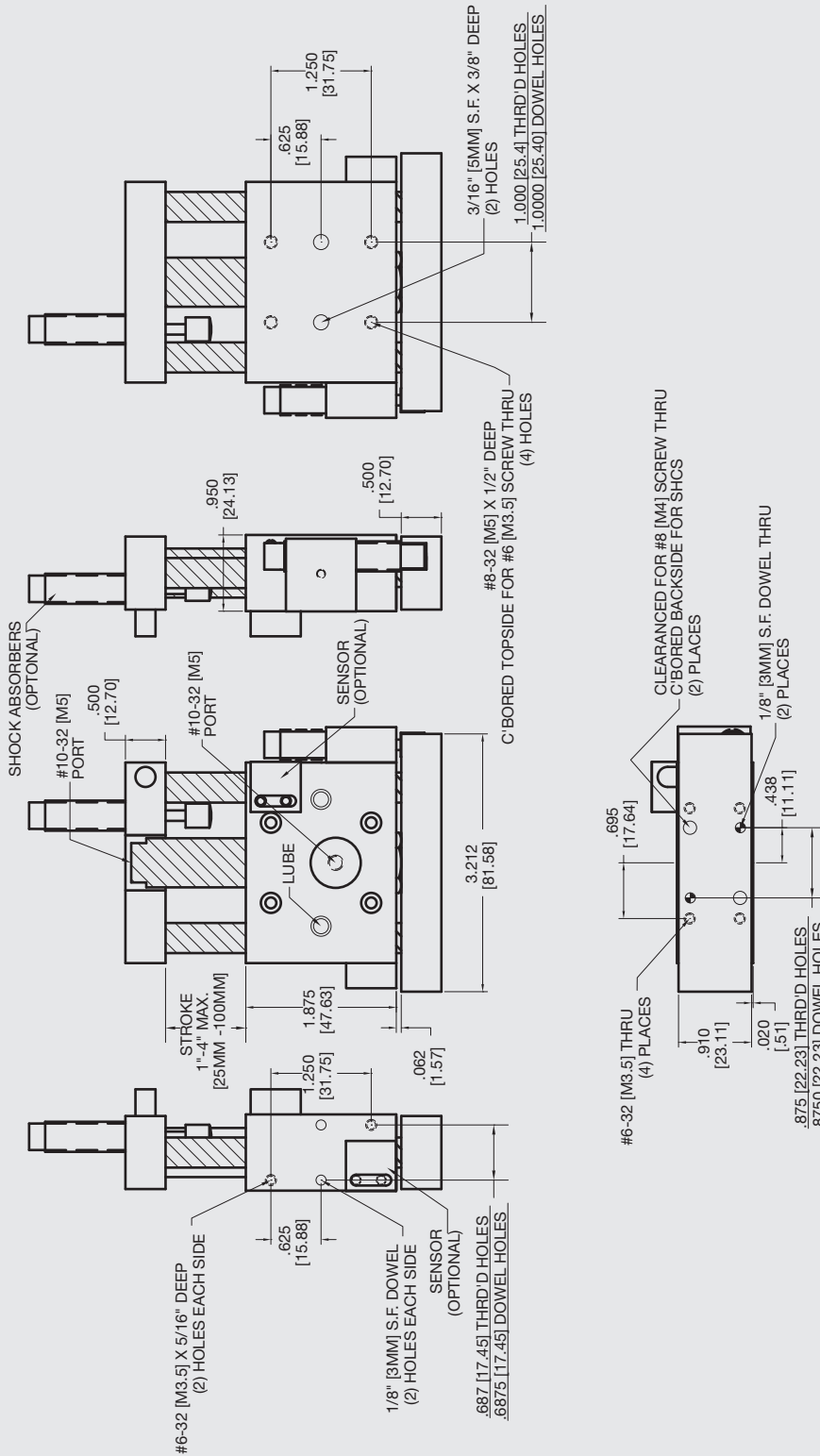

PAYLOAD DATA

Stroke Length	Maximum Load (lbs)	Maximum Moments (in-lbs)	Maximum Deflection	
			P1	P2
1 [25.4 mm]	5 [2.3 kg]	14 [1.6 Nm]	.001 [.03 mm]	.001 [.03 mm]
2 [50.8 mm]	5 [2.3 kg]	10 [1.1 Nm]	.001 [.03 mm]	.001 [.03 mm]
3 [76.2 mm]	5 [2.3 kg]	8 [0.9 Nm]	.002 [.05 mm]	.002 [.05 mm]
4 [101.6 mm]	5 [2.3 kg]	6 [0.7 Nm]	.005 [.13 mm]	.004 [.10 mm]



Unless noted, all tolerances are as indicated here:



All Dowel Holes are SF (Slip Fit) Locational Tolerance ± .0005" [.013mm]



Metric Threads Course Pitch

Imperial:
Inch

0.00 = ±.01
0.000 = ±.005
0.0000 = ±.0005

Metric: [0.] = ±.25
[mm] [0.0] = ±.13
[0.00] = ±.013

AGT-3 Powered Slide

Linear Thruster



FEATURES AND BENEFITS

- Floating piston rod coupling eliminates cylinder binding.
- Compact, lightweight unit with replaceable air-cylinder.
- Units are permanently lubricated.
- Optional stroke adjustment for precise, repetitive operation.
- Proximity switches are available to monitor end of stroke position of the body.
- Optional shock absorbers can be ordered for smooth operation.
- Aluminum body end blocks contain taped holes and dowel pin holes for precision mounting or fixturing.
- Standard end plate to stop shaft vibrations.

SPECIFICATIONS

Design: Replaceable air cylinder, linear bearings on steel hardened shafts

Stroke: 6 in max. (1" increments)
[152 mm] [25.4 mm]

Thrust Force @ 80 PSI [5.5 BAR]

30 lbs (multiply force factor by input pressure in PSI)

Extended: 44 lbs [196 N]

Retract: 39 lbs [174 N]

Recommended Speed:

1-40 in/sec

Pressure Range:

Low/High 20-120 PSI [1.4-8 BAR]

Temperature Range:

Low/High -20°/150°F [-28°/80°C]

Side Play: ± 0.001 [0.03 mm]

Deflection: See Chart

Maximum Payload: 10 lbs [4.5 kg]

Material: High Strength, Aluminum Alloys, Steel Components

Weight: 1.50 lbs + 2 oz/in
[.7 kg + 1.4 g/mm]

Shaft Diameter: 3/8 in [9.5 mm]

Piston Diameter: 3/4 in [19 mm]

January 2009 - PATENTED Made in the USA

PAYLOAD FORCES

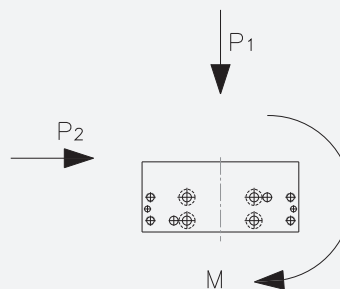

WARNING! Do not exceed mounting screw depth.

LOOK! More Technical specifications for sensors on "Sensors Accessories" page.

HOW TO ORDER

When ordering, please specify:
Design/Model Number and Options.

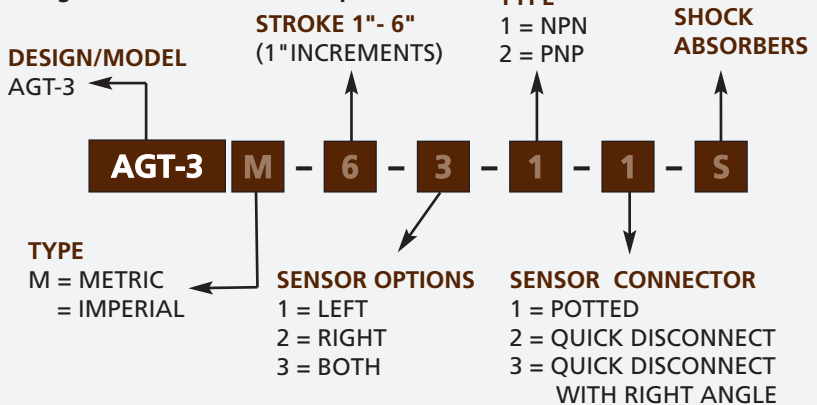

* NOTE: Proximity sensors are 8 mm diam., 12-30 VDC, 50 mA and come with 2 meter cable.

Sensor Part # SNC08, SNQ08, SPC08, SPQ08

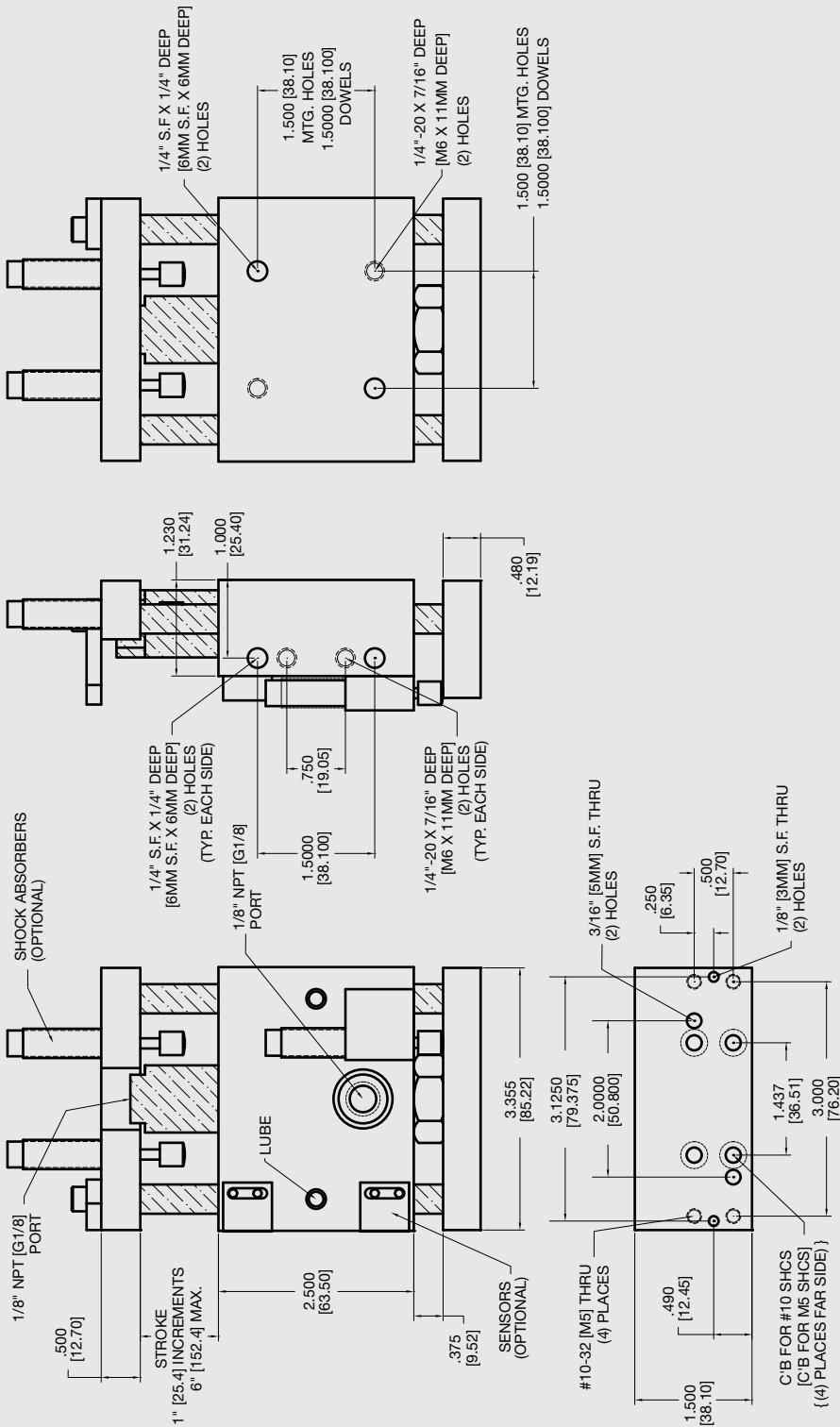

PAYLOAD DATA

Stroke Length	Maximum Load (lbs)	Maximum Moments (in-lbs)	Maximum Deflection	
			P1	P2
1 [25.4 mm]	10 [4.5 kg]	28 [3.2 Nm]	.001 [.03 mm]	.001 [.03 mm]
2 [50.8 mm]	10 [4.5 kg]	22 [2.5 Nm]	.001 [.03 mm]	.001 [.03 mm]
3 [76.2 mm]	10 [4.5 kg]	18 [2.1 Nm]	.002 [.05 mm]	.002 [.05 mm]
4 [101.6 mm]	10 [4.5 kg]	15 [1.7 Nm]	.005 [.13 mm]	.004 [.10 mm]
5 [127.0 mm]	10 [4.5 kg]	13 [1.5 Nm]	.009 [.23 mm]	.006 [.15 mm]
6 [152.4 mm]	10 [4.5 kg]	11 [1.3 Nm]	.012 [.3 mm]	.010 [.25 mm]



Unless noted, all tolerances are as indicated here:



All Dowel Holes are SF (Slip Fit) Locational Tolerance ± .0005" [.013mm]



Metric Threads Course Pitch

Imperial: Inch

0.00 = ±.01
0.000 = ±.005
0.0000 = ±.0005

Metric: [0.] = ±.25
[0.0] = ±.13
[0.00] = ±.013

AGT-4 Powered Slide

Linear Thruster



FEATURES AND BENEFITS

- Floating piston rod coupling eliminates cylinder binding.
- Compact, lightweight unit with replaceable air-cylinder.
- Units are permanently lubricated.
- Optional stroke adjustment for precise, repetitive operation.
- Proximity switches are available to monitor end of stroke position of the body.
- Optional shock absorbers can be ordered for smooth operation.
- Aluminum body end blocks contain taped holes and dowel pin holes for precision mounting or fixturing.
- Standard end plate to stop shaft vibrations.

SPECIFICATIONS

Design: Replaceable air cylinder, linear bearings on steel hardened shafts

Stroke: 8 in max. (1" increments)
[203 mm] [25.4 mm]

Thrust Force @ 80 PSI [5.5 BAR]

70 lbs (multiply force factor by input pressure in PSI)

Extended: 88 lbs [392 N]

Retract: 81 lbs [360 N]

Recommended Speed:

1-40 in/sec

Pressure Range:

Low/High 20-120 PSI [1.4-8 BAR]

Temperature Range:

Low/High -20°/150°F [-28°/80°C]

Side Play: ± 0.001 [.03 mm]

Deflection: See Chart

Maximum Payload: 25 lbs [11.3 kg]

Material: High Strength, Aluminum Alloys, Steel Components

Weight: 3.75 lbs + 3 oz/in
[1.7 kg + 2.6 g/mm]

Shaft Diameter: 1/2 in [12.7 mm]

Piston Diameter: 1 1/16 in [27 mm]

PAYLOAD FORCES

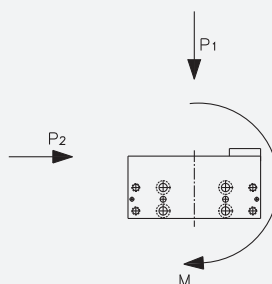

WARNING! Do not exceed mounting screw depth.

LOOK! More Technical specifications for sensors on "Sensors Accessories" page.

HOW TO ORDER

When ordering, please specify:
Design/Model Number and Options.

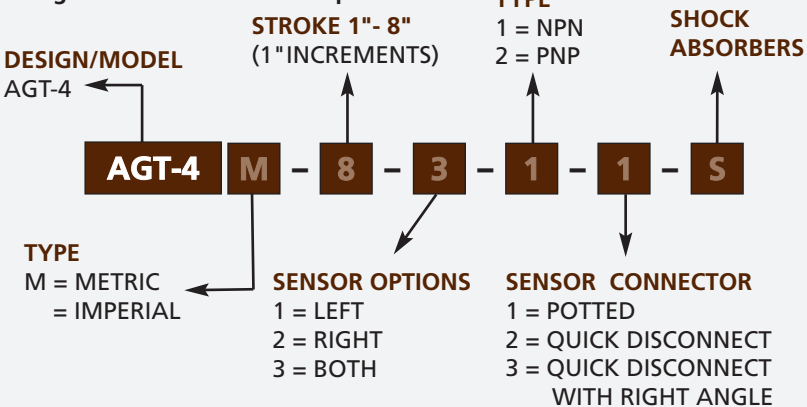

* NOTE: Proximity sensors are 8 mm diam., 12-30 VDC, 50 mA and come with 2 meter cable.

Sensor Part # SNC08, SNQ08, SPC08, SPQ08

January 2009 - PATENTED Made in the USA

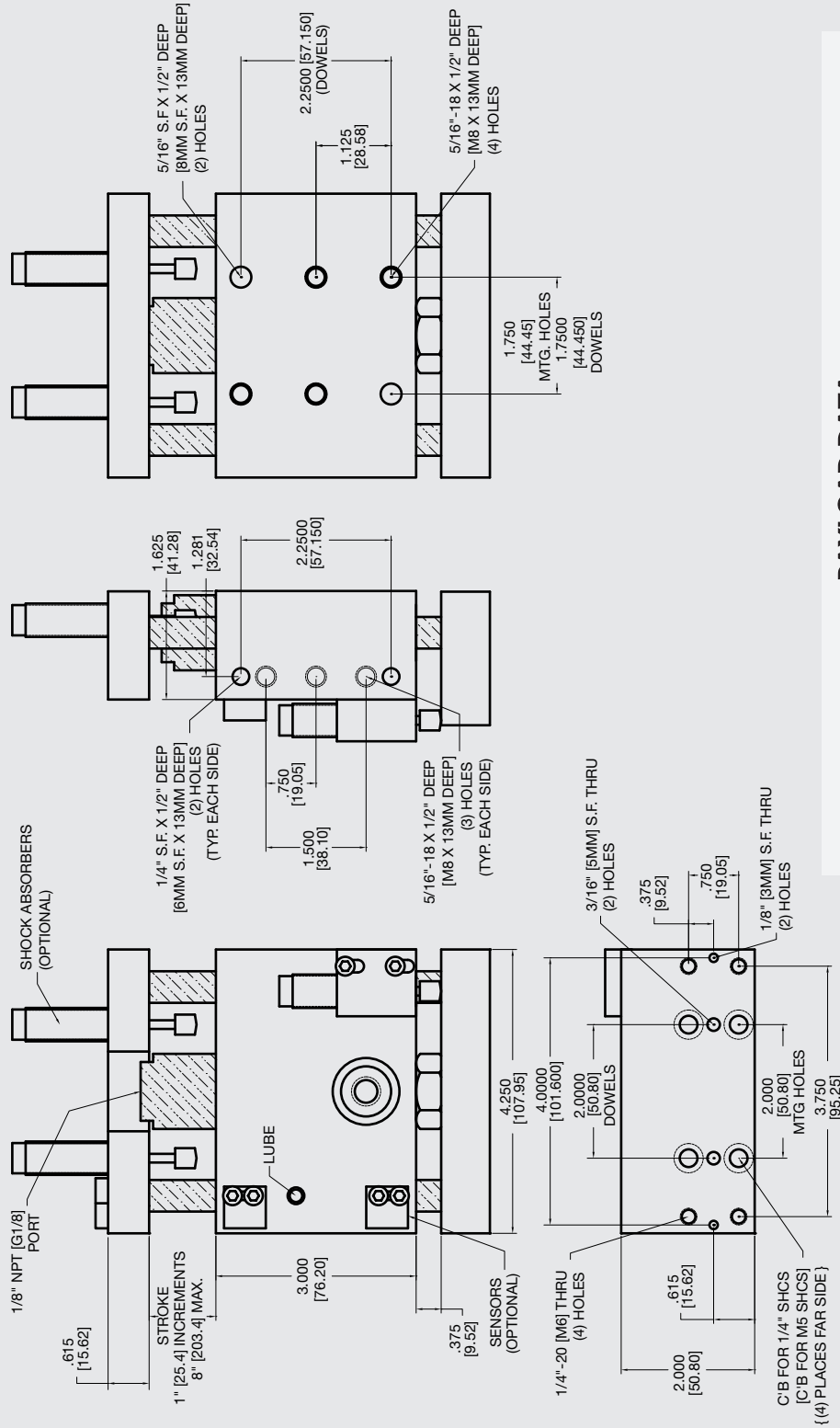

PAYLOAD DATA

Stroke Length	Maximum Load (lbs)	Maximum Moments (in-lbs)	Maximum Deflection P1	Maximum Deflection P2
1 [25.4 mm]	25 [11.3 kg]	95 [10.7 Nm]	.001 [.03 mm]	.001 [.03 mm]
2 [50.8 mm]	25 [11.3 kg]	75 [8.5 Nm]	.002 [.05 mm]	.002 [.05 mm]
3 [76.2 mm]	25 [11.3 kg]	60 [6.7 Nm]	.004 [.10 mm]	.003 [.07 mm]
4 [101.6 mm]	25 [11.3 kg]	53 [6 Nm]	.006 [.15 mm]	.005 [.13 mm]
5 [127.0 mm]	25 [11.3 kg]	46 [5.2 Nm]	.008 [.20 mm]	.007 [.17 mm]
6 [152.4 mm]	25 [11.3 kg]	40 [4.5 Nm]	.014 [.35 mm]	.011 [.28 mm]
7 [XXX mm]	25 [11.3 kg]	36 [4 Nm]	.018 [.45 mm]	.016 [.40 mm]
8 [XXX mm]	25 [11.3 kg]	33 [3.7 Nm]	.022 [.55 mm]	.018 [.45 mm]



Unless noted, all tolerances are as indicated here:



All Dowel Holes are SF (Slip Fit) Locational Tolerance $\pm .0005$ [0.13mm]



Metric Threads Course Pitch

Imperial: Inch
0.00 = $\pm .01$
0.000 = $\pm .005$
0.0000 = $\pm .0005$

Metric: [0.] = $\pm .25$
[0.0] = $\pm .13$
[0.00] = $\pm .013$



AGT-5 Powered Slide Linear Thruster



FEATURES AND BENEFITS

- Floating piston rod coupling eliminates cylinder binding.
- Compact, lightweight unit with replaceable air-cylinder.
- Units are permanently lubricated.
- Optional stroke adjustment for precise, repetitive operation.
- Proximity switches are available to monitor end of stroke position of the body.
- Optional shock absorbers can be ordered for smooth operation.
- Aluminum body end blocks contain taped holes and dowel pin holes for precision mounting or fixturing.
- Standard end plate to stop shaft vibrations.

SPECIFICATIONS

Design: Replaceable air cylinder, linear bearings on steel hardened shafts

Stroke: 12 in max. (1" increments)
[304.8 mm] [25.4 mm]

Thrust Force @ 80 PSI [5.5 BAR]
140 lbs (multiply force factor by input pressure in PSI)

Extended: 1.76 lbs [8 N]

Retract: 1.61 lbs [7 N]

Recommended Speed: 1-40 in/sec
[XX-XX m/sec]

Pressure Range:
Low/High 20-120 PSI [1.4-8 BAR]

Temperature Range:
Low/High -20°/150°F [-28°/80°C]

Side Play: ± 0.001 [.03 mm]

Deflection: See Chart

Maximum Payload: 40 lbs [18.2 kg]

Material: High Strength, Aluminum Alloys, Steel Components

Weight: 7.0 lbs + 6.7 oz/in
[3.2 kg + 5.2 g/mm]

Shaft Diameter: 3/4 in [19 mm]

Piston Diameter: 1 1/2 in [38 mm]

PAYLOAD FORCES

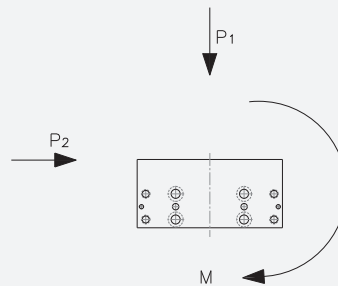

WARNING! Do not exceed mounting screw depth.

LOOK! More Technical specifications for sensors on "Sensors Accessories" page.

HOW TO ORDER

When ordering, please specify:
Design/Model Number and Options.

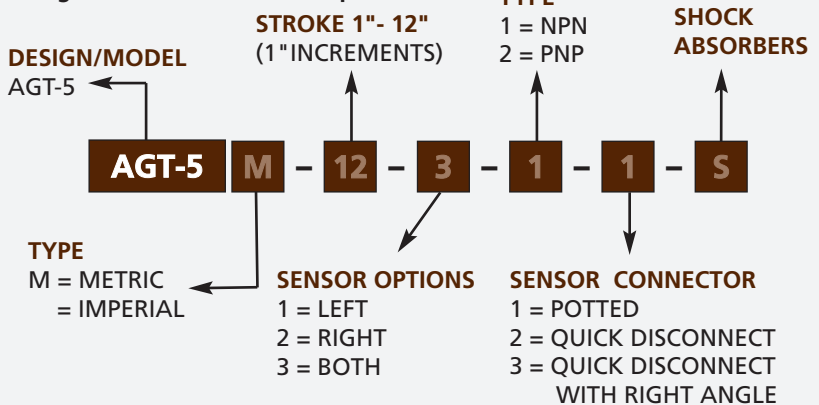

* NOTE: Proximity sensors are 8 mm diam., 12-30 VDC, 50 mA and come with 2 meter cable.

Sensor Part # SNC08, SNQ08, SPC08, SPQ08

January 2009 - PATENTED Made in the USA

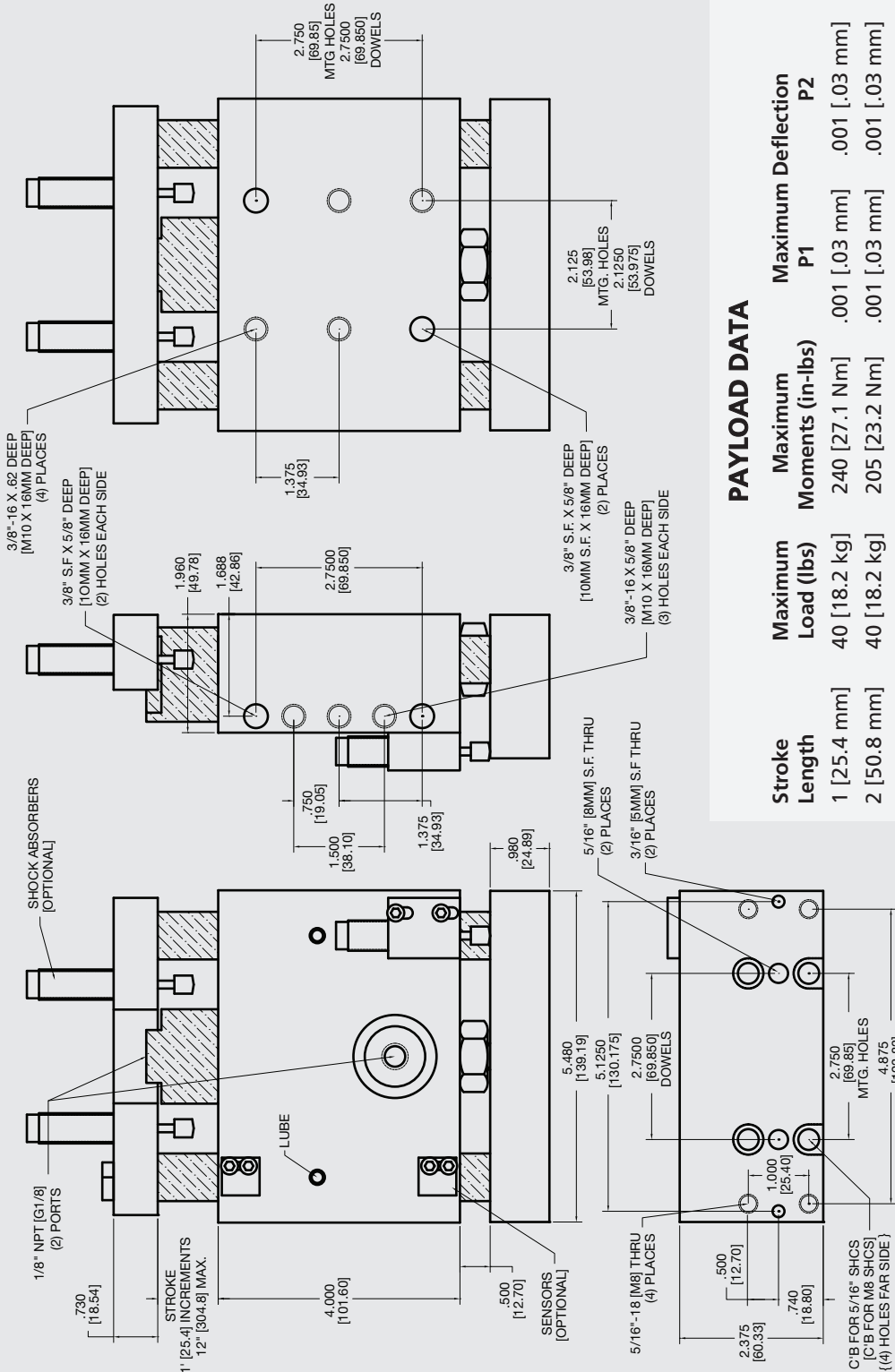

PAYLOAD DATA

Stroke Length	Maximum Load (lbs)	Maximum Moments (in-lbs)	Maximum Deflection P1	Maximum Deflection P2
1 [25.4 mm]	40 [18.2 kg]	240 [27.1 Nm]	.001 [.03 mm]	.001 [.03 mm]
2 [50.8 mm]	40 [18.2 kg]	205 [23.2 Nm]	.001 [.03 mm]	.001 [.03 mm]
3 [76.2 mm]	40 [18.2 kg]	176 [19.9 Nm]	.003 [.07 mm]	.002 [.05 mm]
4 [101.6 mm]	40 [18.2 kg]	155 [17.5 Nm]	.004 [.10 mm]	.003 [.07 mm]
5 [127.0 mm]	40 [18.2 kg]	137 [15.5 Nm]	.007 [.17 mm]	.006 [.15 mm]
6 [152.4 mm]	40 [18.2 kg]	120 [12.5 Nm]	.009 [.22 mm]	.007 [.17 mm]
7 [XXX mm]	40 [18.2 kg]	110 [12.5 Nm]	.012 [.30 mm]	.010 [.25 mm]
8 [XXX mm]	40 [18.2 kg]	100 [11.3 Nm]	.016 [.40 mm]	.013 [.33 mm]
9 [XXX mm]	40 [18.2 kg]	93 [10.5 Nm]	.019 [.50 mm]	.016 [.40 mm]
10 [XXX mm]	40 [18.2 kg]	86 [9.7 Nm]	.022 [.55 mm]	.018 [.45 mm]
11 [XXX mm]	40 [18.2 kg]	80 [9 Nm]	.024 [.60 mm]	.020 [.50 mm]
12 [XXX mm]	40 [18.2 kg]	75 [8.5 Nm]	.025 [.63 mm]	.021 [.53 mm]

Unless noted, all tolerances are as indicated here:



All Dowel Holes are SF (Slip Fit) Locational Tolerance $\pm .0005"$ [.013mm]



Metric Threads Course Pitch

Imperial: Inch

0.00 = $\pm .01$
0.000 = $\pm .005$
0.0000 = $\pm .0005$

Metric: [.] = $\pm .25$
[0.] = $\pm .13$
[0.00] = $\pm .013$





AGE Series

Escapements





AGE-1 Feed Escapement

Built-in Air Cylinder

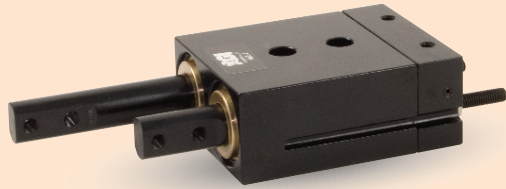

FEATURES AND BENEFITS

- Compact, Long Stroke Escapements made for separating and isolating individual parts from tracks, vibratory feeders or conveyors.
- Internal sequencing and cross porting make sure both rods are extended before either rod can retract, ensuring positive part feeding.
- Easy part jam clearing due to internal back pressure cross port design, this allows both rods to be retracted with the air off.
- Piston seals are U-CUP type for long service life.
- Hall effect sensors are available to monitor stroke position at any point in the stroke.
- Adjustable stroke on retraction.

SPECIFICATIONS

Design: Double Acting, Internal Sequencing

Stroke 1 in 25 mm
Option: Adjustable Stroke

Thrust Force: @80 psi [5.5 BAR]

Extend Force: 18 lb [80 N]

Retract Force: 10 lb [45 N]

Time: .35 Sec [.35 sec]

Pressure Range:

Low/High 20-120 PSI [1.4-8 BAR]

Temperature Range:

Low/High -20°/180°F [-28°/80°C]

Side Play:

± .002 in ± 0.06 mm

Loading Capacity:

	Static	Dynamic
Max Moment M_x	50 lbs [6 Nm]	5 lbs [0.6 Nm]
Max Moment M_y	50 lbs [6 Nm]	5 lbs [0.6 Nm]
Max Moment M_z	50 lbs [6 Nm]	5 lbs [0.6 Nm]

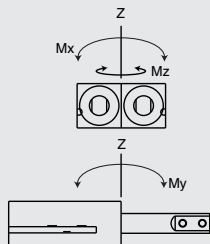

Material: High Strength, Aluminum Alloys, Bronze

Weight: 8 oz [227 g]

Piston Diameter: .563 in [14 mm]

TYPICAL OPERATION:

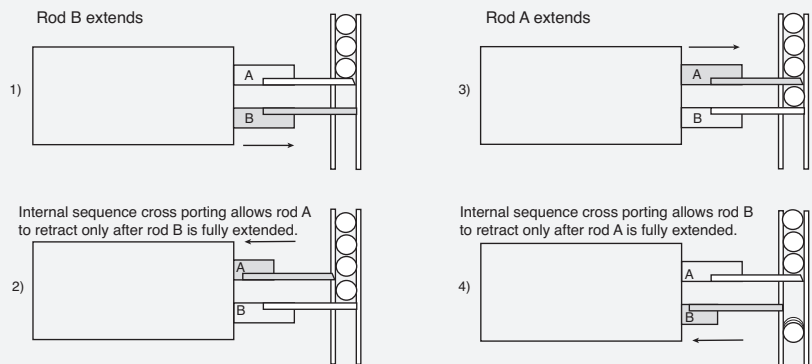

AGI Escapements are two double acting cylinders that are cross ported and internally sequenced. A four way, two position valve is needed to operate this escapement. ***Rods A and B must be allowed to extend to the end of it's stroke to operate.**

HOW TO ORDER

When ordering, please specify:
Design/Model Number and Options.

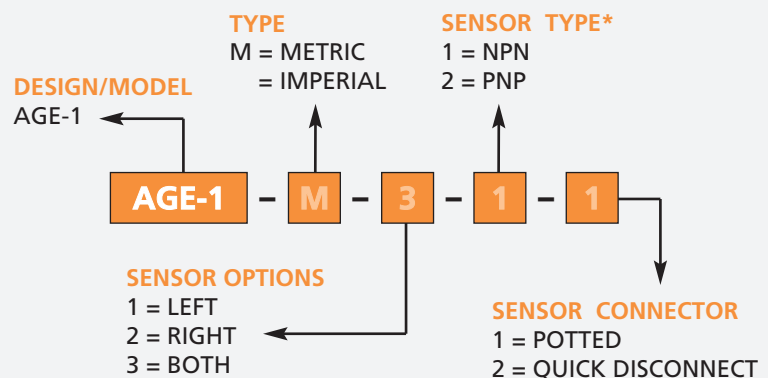

* NOTE: Hall Effect Sensors are hard wired with a 20" pigtail.

Sensor Part # SHN01, SHP01, SHNQ3, SHPQ3

January 2009 - PATENTED Made in the USA

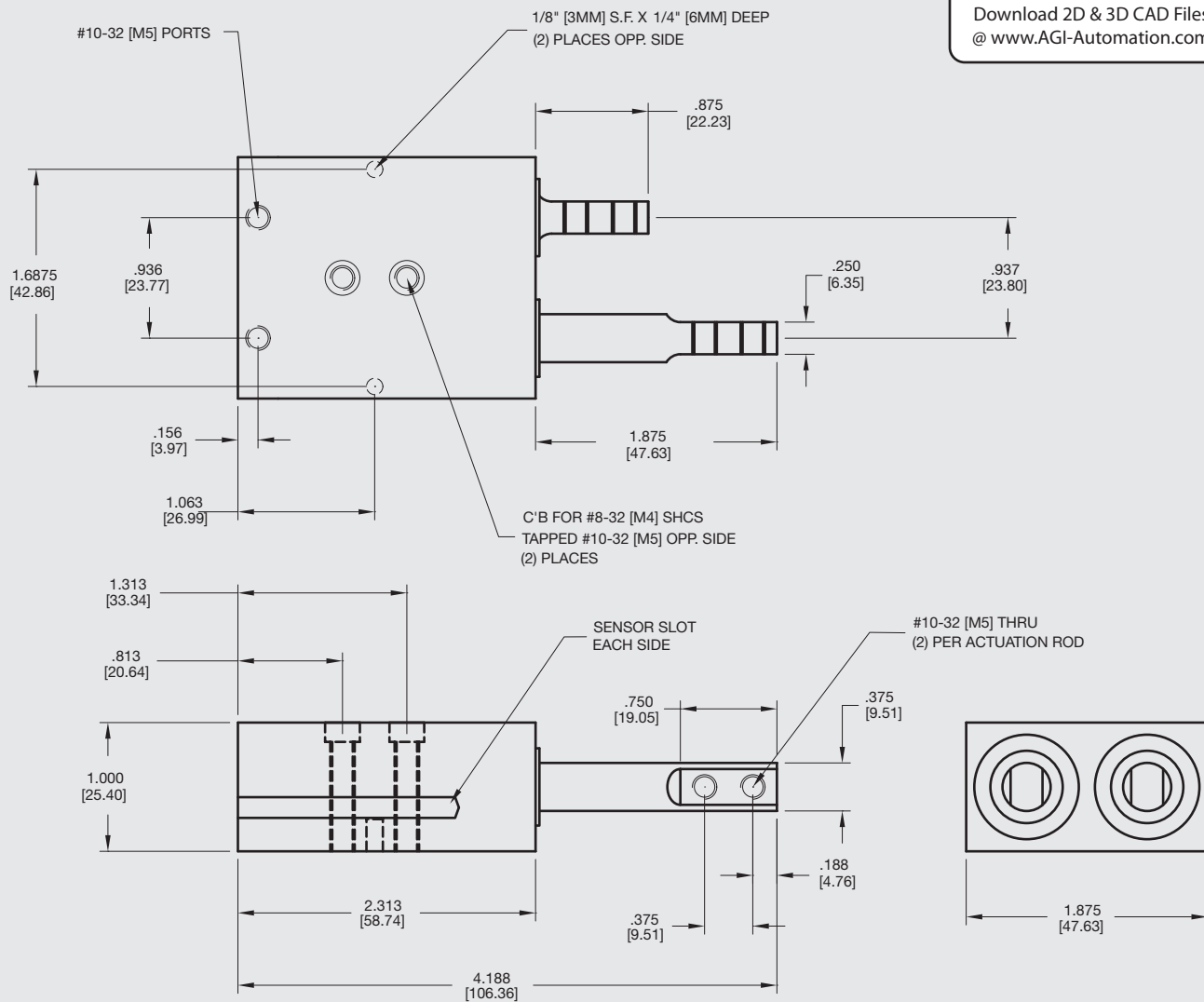

Unless noted, all tolerances are as indicated here:



All Dowel Holes are SF (Slip Fit) Locational Tolerance $\pm .0005"$ [.013mm]



Metric Threads Course Pitch

Imperial:
Inch

0.00 = $\pm .01$
0.000 = $\pm .005$
0.0000 = $\pm .0005$

Metric:
[0.] = $\pm .25$
[0.0] = $\pm .13$
[0.00] = $\pm .013$

AGE-2 Feed Escapement

Built-in Air Cylinder

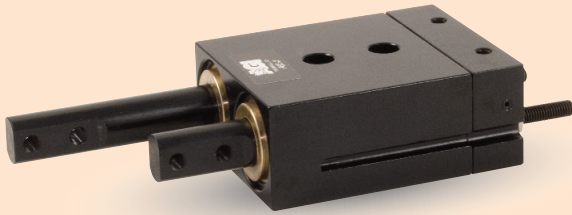

FEATURES AND BENEFITS

- Compact, Long Stroke Escapements made for separating and isolating individual parts from tracks, vibratory feeders or conveyors.
- Internal sequencing and cross porting make sure both rods are extended before either rod can retract, ensuring positive part feeding.
- Easy part jam clearing due to internal back pressure cross port design, this allows both rods to be retracted with the air off.
- Piston seals are U-CUP type for long service life.
- Hall effect sensors are available to monitor stroke position at any point in the stroke.
- Adjustable stroke on retraction.

SPECIFICATIONS

Design: Double Acting, Internal Sequencing

Stroke 1.25 in 31.7 mm
Option: Adjustable Stroke

Thrust Force: @80 psi [5.5 BAR]

Extend Force: 35 lb [155 N]

Retract Force: 33 lb [146 N]

Time: .35 Sec [.35 sec]

Pressure Range:

Low/High 20-120 PSI [1.4-8 BAR]

Temperature Range:

Low/High -20°/180°F [-28°/80°C]

Side Play:

± .002 in ± 0.06 mm

Loading Capacity:

	Static	Dynamic
Max Moment M_x	150 lbs [11.3 Nm]	13 lbs [2.8 Nm]
Max Moment M_y	150 lbs [11.3 Nm]	13 lbs [2.8 Nm]
Max Moment M_z	150 lbs [11.3 Nm]	13 lbs [2.8 Nm]

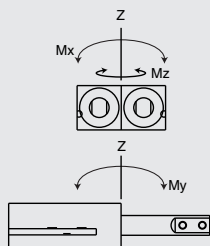

Material: High Strength, Aluminum Alloys, Bronze

Weight: 12 oz [340 g]

Piston Diameter: .750 in [19 mm]

TYPICAL OPERATION:

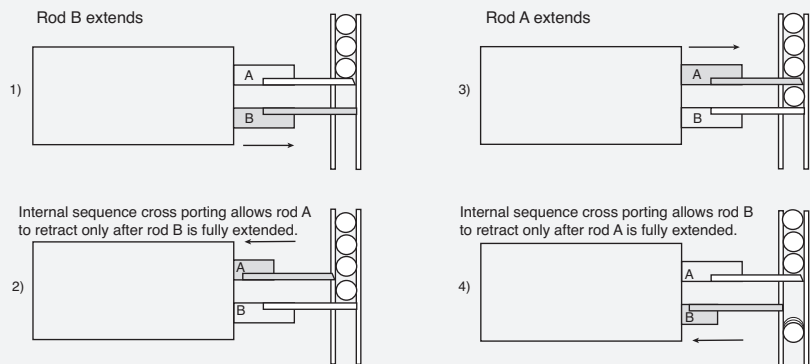

AGI Escapements are two double acting cylinders that are cross ported and internally sequenced. A four way, two position valve is needed to operate this escapement. ***Rods A and B must be allowed to extend to the end of it's stroke to operate.**

HOW TO ORDER

When ordering, please specify:
Design/Model Number and Options.

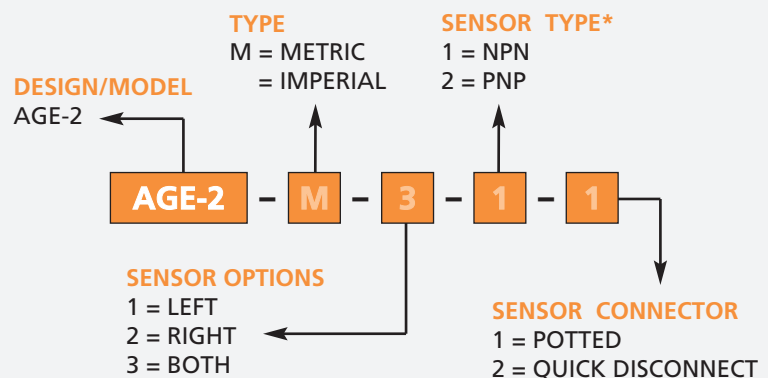

* NOTE: Hall Effect Sensors are hard wired with a 20" pigtail.

Sensor Part # SHN01, SHP01, SHNQ3, SHPQ3

January 2009 - PATENTED Made in the USA

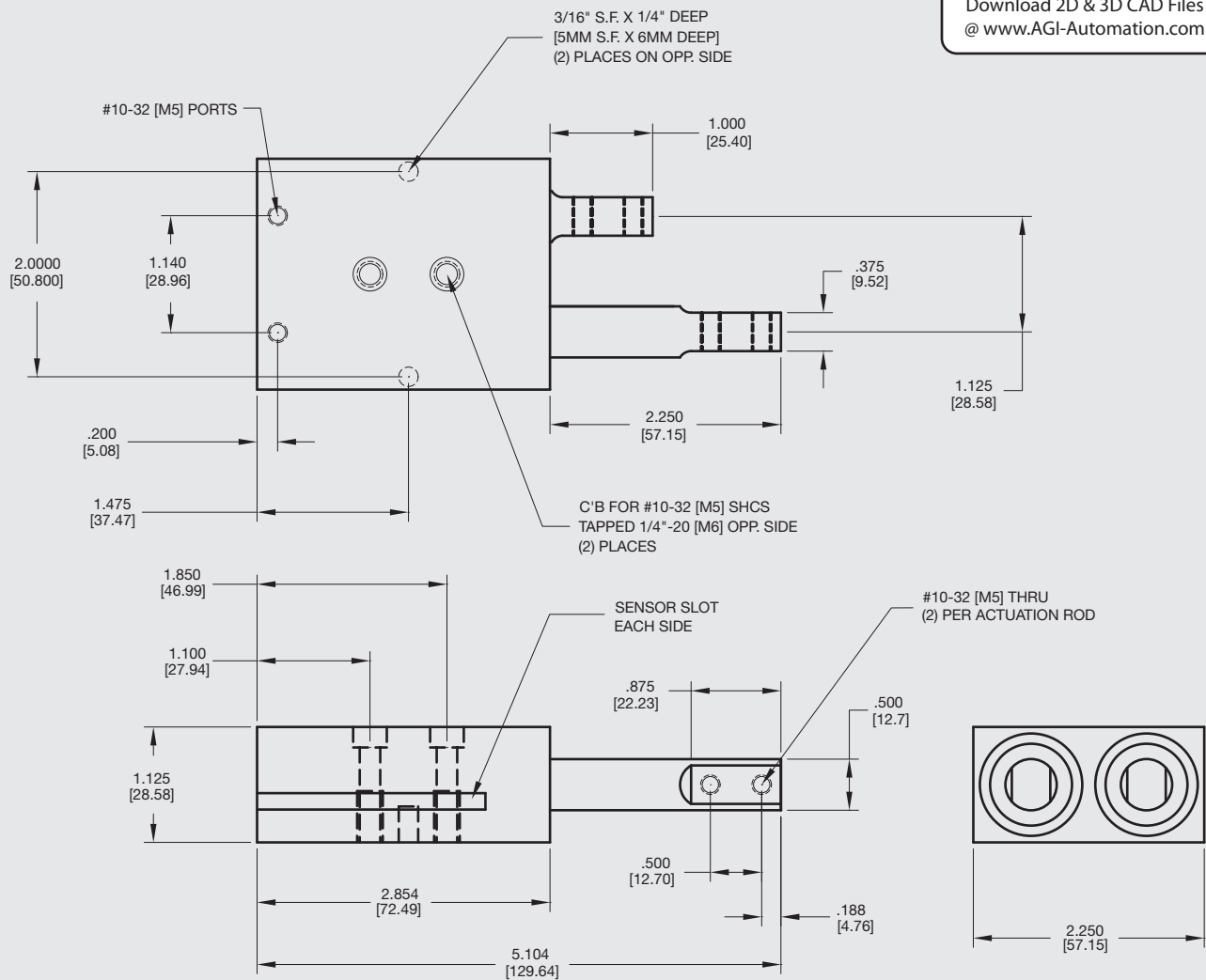

Unless noted, all tolerances are as indicated here:



All Dowel Holes are SF (Slip Fit) Locational Tolerance $\pm .0005"$ [0.013mm]



Metric Threads Course Pitch

Imperial: Inch

0.00 = $\pm .01$
0.000 = $\pm .005$
0.0000 = $\pm .0005$

Metric: [0.] = $\pm .25$
[0.0] = $\pm .13$
[0.00] = $\pm .013$

AGE-3 Feed Escapement

Built-in Air Cylinder

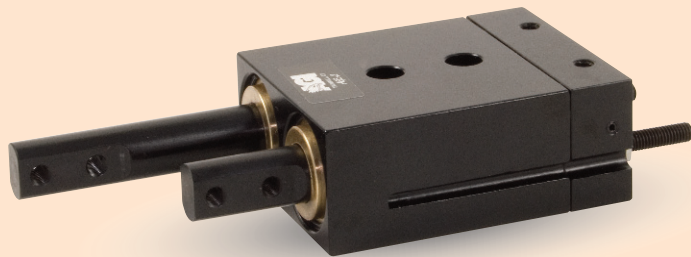

FEATURES AND BENEFITS

- Compact, Long Stroke Escapements made for separating and isolating individual parts from tracks, vibratory feeders or conveyors.
- Internal sequencing and cross porting make sure both rods are extended before either rod can retract, ensuring positive part feeding.
- Easy part jam clearing due to internal back pressure cross port design, this allows both rods to be retracted with the air off.
- Piston seals are U-CUP type for long service life.
- Hall effect sensors are available to monitor stroke position at any point in the stroke.
- Adjustable stroke on retraction.

SPECIFICATIONS

Design: Double Acting, Internal Sequencing

Stroke 1.56 in 39 mm
Option: Adjustable Stroke

Thrust Force: @80 psi [5.5 BAR]

Extend Force: 60 lb [270 Kg]

Retract Force: 52 lb [231 Kg]

Time: .35 Sec [.35 sec]

Pressure Range:

Low/High 20-120 PSI [1.4-8 BAR]

Temperature Range:

Low/High -20°/180°F [-28°/80°C]

Side Play:

± .002 in ± 0.06 mm

Loading Capacity:

	Static	Dynamic
Max Moment M_x	230 lbs [24 Nm]	24 lbs [2.6 Nm]
Max Moment M_y	230 lbs [24 Nm]	24 lbs [2.6 Nm]
Max Moment M_z	230 lbs [24 Nm]	24 lbs [2.6 Nm]

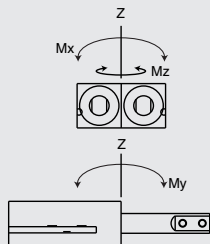

Material: High Strength, Aluminum Alloys, Bronze

Weight: 1 lb [0.45 Kg]

Piston Diameter: 1 in [25 mm]

TYPICAL OPERATION:

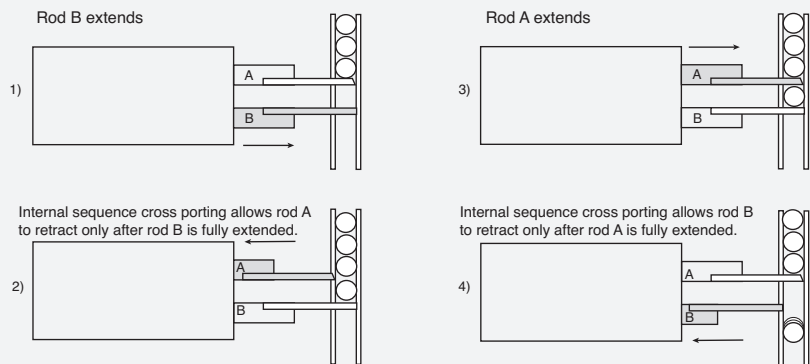

AGI Escapements are two double acting cylinders that are cross ported and internally sequenced. A four way, two position valve is needed to operate this escapement. ***Rods A and B must be allowed to extend to the end of it's stroke to operate.**

HOW TO ORDER

When ordering, please specify:
Design/Model Number and Options.

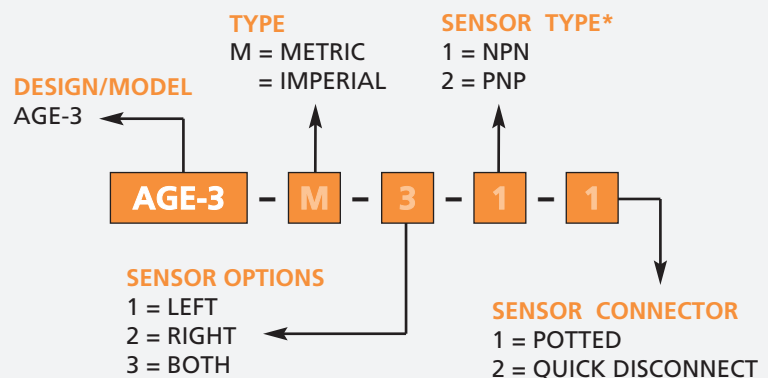

* NOTE: Hall Effect Sensors are hard wired with a 20" pigtail.

Sensor Part # SHN01, SHP01, SHNQ3, SHPQ3

January 2009 - PATENTED Made in the USA

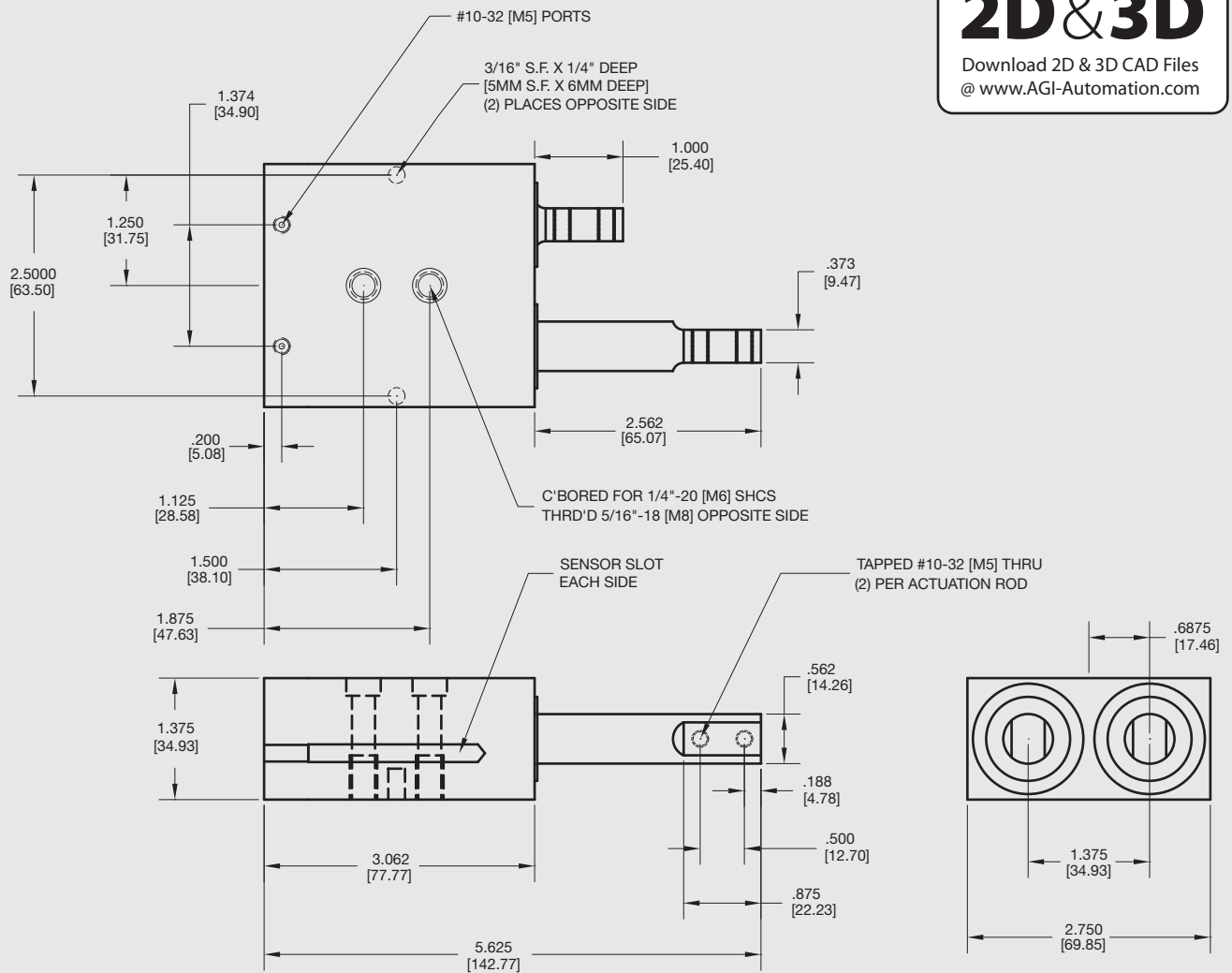
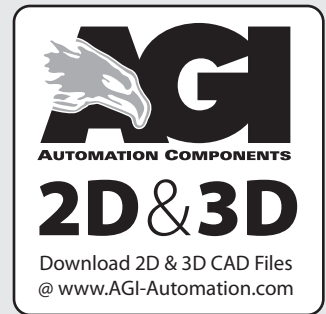

Unless noted, all tolerances are as indicated here:



All Dowel Holes are SF (Slip Fit) Locational Tolerance $\pm .0005"$ [.013mm]



Metric Threads Course Pitch

Imperial:
Inch

0.00 = ± 0.1
0.000 = ± 0.005
0.0000 = ± 0.0005

Metric:
[mm]
[0.] = ± 0.25
[0.0] = ± 0.13
[0.00] = ± 0.13



AGMS Single Finger Escapement

Built-in Air Cylinder

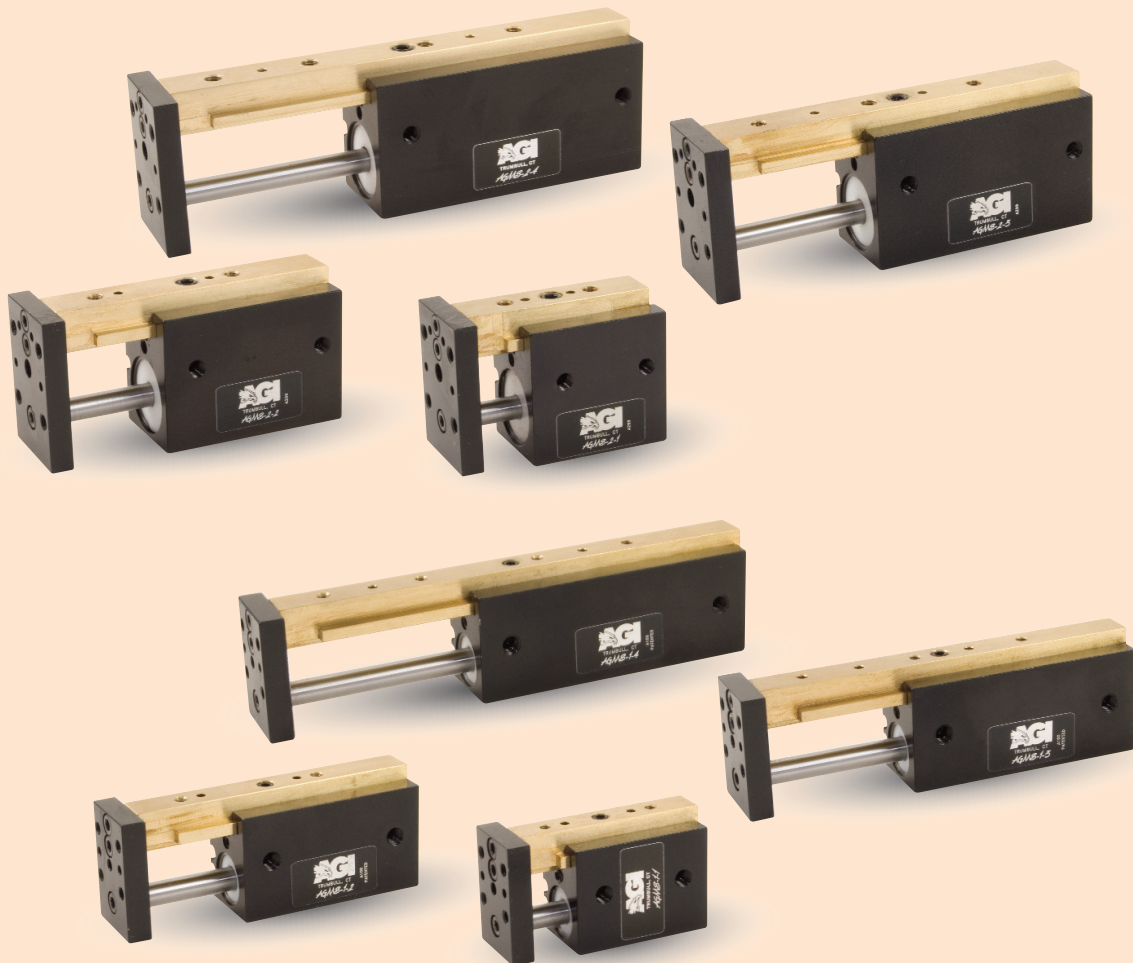

FEATURES AND BENEFITS

- T-Slot bearing support for the carriage and end plate offers superior load bearing performance throughout the stroke.
- Standard built-in stroke adjustment and stroke lock for precise, repetitive operation.
- Compact, lightweight unit with built-in cylinder.
- Piston seals are U-CUP type for long service life.
- Hall Effect sensors are available to monitor stroke position.
- Multiple mounting surfaces on the body and endplate with threaded and counterbored holes for easy mounting choices.

For detailed product specifications and CAD drawings,
please visit our website at www.AGI-Automation.com

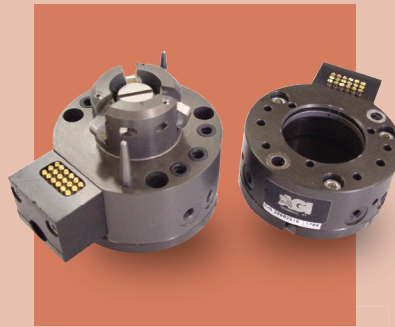

AGO Series
AGC Series

Tool Changers Load Limiters





AGO Load Limiter

See: www.agi-automation.com for full data

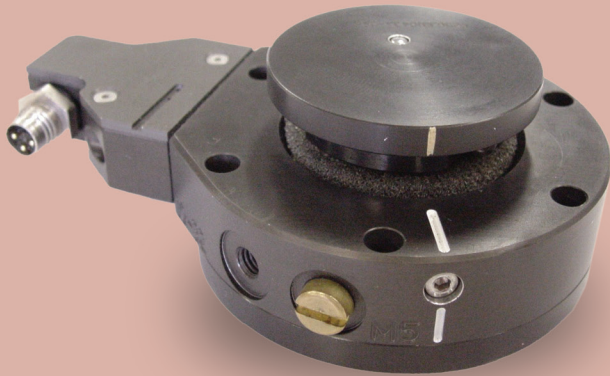

FEATURES AND BENEFITS

- Dynamically Variable Trip Points
- High Reliability
- Quick Reaction Time
- Monitors Performance Readiness
- Load Limiter Becomes Compliant

Model	Torque Trip Point	Moment Trip Point	Mass	Diameter	Profile
	N-m (in-lb)	N-m (in-lb)	kg (lb)	mm (in)	mm (in)
AGO-1	.28-1.5 (2.5-13.5)	.31-1.5 (2.7-13.2)	.11 (.24)	40 (1.6)	27 (1.1)
AGO-2	1.0-6.4 (9-56)	1.0-6.4 (9-56)	0.26 (0.56)	63.5 (2.5)	32 (1.2)
AGO-3	2.2-14.0 (19-124)	2.6-11.8 (23-104)	0.29 (0.65)	71 (2.8)	35 (1.3)
AGO-4	5.3-30.4 (47-270)	4.1-20.3 (36-180)	0.45 (0.99)	83 (3.3)	37 (1.4)
AGO-5	7.5-45.2 (66-400)	5.9-32.4 (52-287)	0.68 (1.5)	97 (3.8)	43.5 (1.7)

ROBOTS SAFELY CRASH WITH PROTECTION

The AGO series Pneumatic Collision Sensors features seven new models that are suited for a wide variety of applications to increase production. There are many names for the robotic safety devices, crash protectors, collision sensors, EOAT load limiter and so on. They all have the same purpose and that's to minimize or completely prevent damage to robot and tooling.

The AGO unit mounts between the robot and the tooling to protect them in an overload condition or collision. The AGI pneumatically actuated load-limiter has dynamically infinite variable breakaway points. The moment trip point settings can be controlled by air pressure and is compliant in the X, Y and Z axes and rotational.

Pneumatic pressure can be added to increase moment capacity for high-inertia motions and reduced when low-inertia moves are needed. A regulated air supply provides positive, variable pressure to hold the load rigid during normal operation. At impact, the air chamber seal is opened and becomes compliant, while a pressure switch signal is immediately sent to the system controller or robot's E-stop to shut down the system. Precise locating components are used to ensure that it repeats back to its original position with less than .001 inch.

The AGI robotic collision protector, production and assembly lines run longer, expensive robots and tools are protected and costly system repairs are drastically reduced on end of arm tooling.

AGI supplies a complete range of sophisticated automation products that include, Pneumatic parallel grippers, rotary actuators, thrusters, linear actuator slides, mini slides, tool changers, overload devices. Available in imperial and metric versions for flexibility of design for a world market.

For more information on this product, send for a FREE catalog today. For immediate assistance, call AGI, (203) 459-8345 or visit our web site at www.agi-automation.com



AGC Tool Changer System

See: www.agi-automation.com for full data



FEATURES AND BENEFITS

- Fail Safe
- Handles High Moments and Extremely High Repeatability
- Low Deflection
- Coupling Window

Model	Moment load graph	Repeatability X&Y	Repeatability Z	Weight	Profile	Diameter	User Electrical Lines	Pneumatic Ports
AGC-20	in-lb N-m	± .025 mm ± .001 in	± .025 mm ± .001 in	0.40 kg 0.91 lb	46.50 mm 1.83 in	60 mm 2.3 in	18 @ 5 Amp each	(6) M5
AGC-40	in-lb N-m	± .025 mm ± .001 in	± .025 mm ± .001 in	1.88kg 4.14 lb	63 mm 2.48 in	101.5 mm 4.0 in	22 @ 5 Amp each	(8) 1/8" NPT

ROBOTIC TOOL CHANGERS OFFER IMPROVED PRODUCTION AND SAFETY.

The AGI robotic tool changer provides the flexibility to automatically changed end-effectors, as part of improving production cycles in a given cell. A robot will use a pneumatic gripper to pick up and position a part, after that it exchanges the gripper for a grinder. When the grinder is complete, the robot drops of the tool and reattaches the gripper, so it can remove the piece from its fixture and pick up another part.

Another common application is here a robot uses a single end effector for a given product run, only changing every couple of hours, so tool changers can both cut costs and increase throughput.

Routine maintenance is another application in which tool changers help reduce the down time. The tool changer justifies its expense because end effectors can be swapped out in a matter of seconds, as opposed to hours so production can continue.

Safety is key in any factory environment. AGI's pneumatic Tool Changer are equipped with a fail safe locking mechanism that will not drop your part even if air pressure fails. The locking mechanism relies on a pneumatically driven piston that forces three cam fingers into a steel ring in the tool-side piece, both locking it in place and clamping the two pieces together. The cam geometry ensures the robot- and tool-side do not come apart in to event of lost air pressure.

The pneumatically actuated robotic tool changer provides the flexibility to automatically change grippers or other peripheral end effector tooling. AGI offers seven different sizes of Tool-Changers, ranging from 1" in diameter for lab use to 10" in diameter. Tool Changers handle high load capacities up to 6000 in-lbs and a repeatability of + 0.01. Tool Changers (Robot side and Tool side) that have been design to connect electrical contacts and Pneumatic ports.

AGI supplies a complete range of sophisticated automation products that include, Pneumatic parallel grippers, rotary actuators, thrusters, linear actuator slides, mini slides, tool changers, overload devices. Available in imperial and metric versions for flexibility of design for a world market.

For more information on this product, send for a FREE catalog today. For immediate assistance, call AGI, (203) 459-8345 or visit our web site at www.agi-automation.com



Sensors

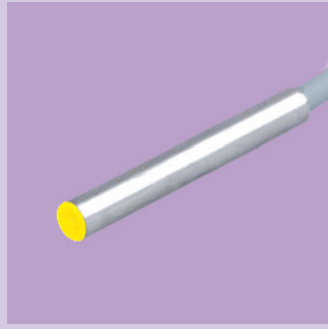

Inductive Sensors
Hall Effect Sensors
Quick Disconnect
Cables



INDUCTIVE SENSORS

Potted-In Cable: Picoprox®

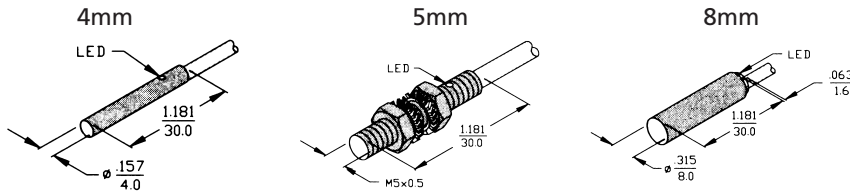

Quick Disconnect: Picofast™

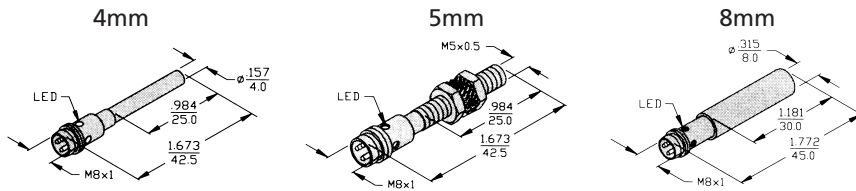

Picoprox and Picofast are registered trademarks of TURCK

Ripple	<10%.
Differential Travel (Hysteresis)	1-15% (5% typ.)
Voltage Drop Across Conducting Sensor	<1.8 V at 100mA
Trigger Current for Overload protection	>120mA
Continuous Load Current	<100mA
Off-State (Leakage) Current	<10mA
No-Load Current	5.5-9.5 mA
Time Delay Before Availability	<8.0 ms
Power-On False Pulse Suppression	Incorporated

Reverse Polarity Protection	Incorporated
Wire-Break Protection	Incorporated
Transient Protection	1 kV, 0.1 ms, 1kO
Operating Temperature	-25C to + 70C (-13F to + 158F)
Enclosure	Meets NEMA 1,3,4,6,13 and IEC IP 67
Shock	30 g, 11 ms
Vibration	55 Hz, 1 mm Amplitude in all 3 Planes
Repeatability	<2% of rated Operating Distance
LED Function	Red: Output Energized

NPN Wiring Diagram (Sinking)

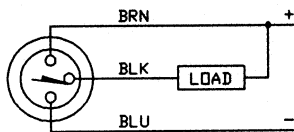

Female Pinout

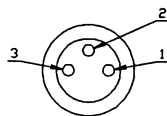

Conductor Colors:
1 = Brown
2 = Black
3 = Blue

PNP Wiring Diagram (Sourcing)

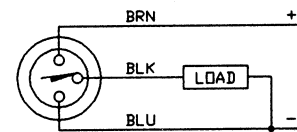

HALL EFFECT SENSORS (SOLID STATE)

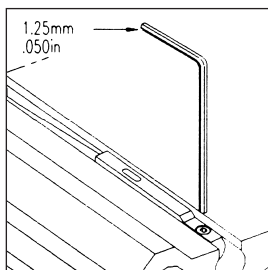

NOTE: Maximum torque on set screw is .170 N-m (1.5 in-lbs.)
Do not overtorque.

Output Type	Current Sinking or Sourcing
Input Voltage	5 to 24 V DC
Input Current	25 mA max.
"ON" Voltage Drop	
Sinking	0.4 Volts max.
Sourcing	1.5 Volts max.
Output Current	25mA max.
Power Dissipation	300 mW max.
Turn ON Time	1 μ Seconds
OFF State Leakage	10 μA max.
Temperature Range	-25° to +85°C
Logic	Normally Open

Sourcing (PNP) Output

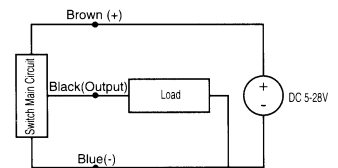

Sinking (NPN) Output

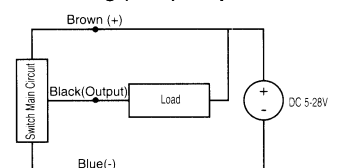



Order Info, Terms & Warranty

ORDERING INFORMATION

BY MAIL: AGI, 171 Spring Hill Road,
Trumbull, CT 06611

BY PHONE: (203) 459-8345

BY FAX: (203) 452-5943

BY EMAIL: amerigrip@aol.com

TERMS AND CONDITIONS

METHOD OF SHIPMENT: U.P.S Ground or specified by customer.

TERMS: NET 30 to established accounts, 2% discount 10 days,
F.O.B. Trumbull, CT.

MINIMUM ORDER: \$50.00 minimum order.

PRICING: All prices are subject to change without notice.

RETURNED GOODS: A return authorization number (RA#) must be obtained prior to returning merchandise for replacement or repair. There will be a 20% restocking charge applied to items authorized for return.

CLAIMS: Claims of shortages, pricing errors, or erroneous charges should be presented within 10 (ten) days of receipt of goods.

LIMITED WARRANTY

All American Grippers Inc. (AGI) product(s) are warranted to be free of defects in materials and workmanship for a period of one year of shipment from the factory. American Grippers Inc. (AGI) warranty is limited to repairing or replacing product(s), at it's option, F.O.B. the factory, upon American Grippers Inc. (AGI) inspection. American Grippers Inc. (AGI) warranty requires written permission prior to returning product for warranty inspection purpose. This warranty shall not apply to any product(s), which has been subject to improper installation, tampering, modification, abuse, operating conditions or application. Apart from the above warranty, these express warranties are in lieu of and exclude all other representations made—both expressed and, or implied. There are no warranties of merchantability of fitness for a particular purpose for products covered by these terms and conditions, which extend beyond the description of the face hereof. Governing Law: The sale and purchase of product(s) covered hereby and all terms and conditions hereof shall be governed by the law of Connecticut. American Grippers Inc. (AGI) reserves the right to change specifications, design and prices without prior written notice.

